

Job Name: 25-3118 - W6 Ph 2-C Force Main Improvements
 Job Location: Fort Mitchell, KY 41017
 Contractor: Lykins Contracting

Plant: 100

3/20/2026 1:21:57 PM

Tech: J. Horsley - A

PC: Celina Goff



Structure ID: 2301568

P1 MH060BAVF

MH BASE (10"F) Custom Ht T/n

- P5) 24" - CASTING HEIGHT - 7"
- P4) 48" - CON CONE w/24" HOLE F/G - 36"
- P3) 48" - MH RISER T/G - 60"
- P2) 60" - MH Transition Slab 48" Hole T/G - 15"
- P1) 60" - MH BASE (10"F) Custom Ht T/n - 66"
- 1) 60" - MH INVERT CHANNEL - FULL HEIGHT
- 1) 60" - Conseal CS-102 1.00" (Double)
- 2) 48" - Conseal CS-102 1.00" (Double)
- 2) A-Lok - 1235
- 13) MH Step ML-10-TDS-NCR - 10"

0 lb
 2252 lb
 4192 lb
 2204 lb
 8952 lb
 2692 lb
 0 lb
 0 lb
 2 lb
 0 lb

 Structure Total: 20294 lb

Structure Notes:

1. PER ASTM C-478 SPECIFICATIONS
2. CONCRETE: 4,000 PSI AT 28 DAYS
3. REINFORCEMENT:
 - WALLS: PER ASTM A615 - DOUBLE MAT
 - FLOOR: #5 BAR @ 12" C.C. E.W. (GRADE 60) - 2" MIN. REBAR CLEARANCE (TYP)
4. INVERT CHANNEL REQUIRED
5. STEPS AT 270 DEGREES
6. 7" CASTING SUPPLIED BY OTHERS

Rim: 761.59' Rim to Invert: 15.32' Slack: 2.84" Sump: 3" Step Position: 270°

Position	Elev	Angle	Ext. (cw)	Pipe	Pipe OD	Connector	Hole	Horz Size	Up ()	Offset
Invert 1	746.27'	0°	0"	36" PVC SDR35/F679	38.3"	A-Lok 1235	39.88"	43.623"	1.125"	0"
Invert 2	746.37'	181°	113.75"	36" PVC SDR35/F679	38.3"	A-Lok 1235	39.88"	43.623"	2.25"	0"
Invert 3										
Invert 4										
Invert 5										
Invert 6										
Invert 7										
Invert 8										

RIGHT-SIDE UP VIEW (int. dimensions)

UPSIDE-DOWN VIEW (int. dimensions)

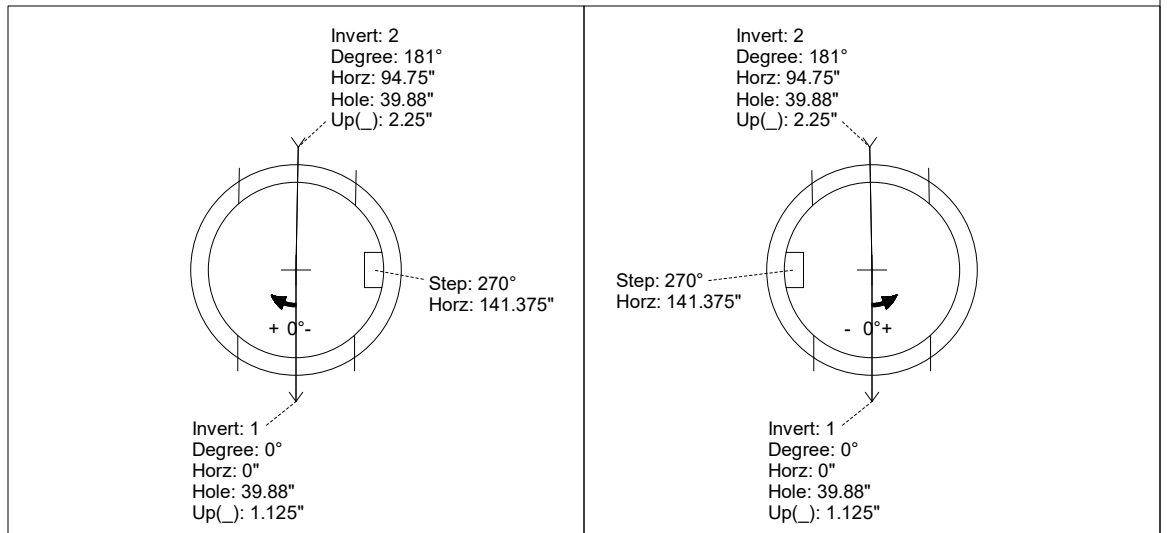
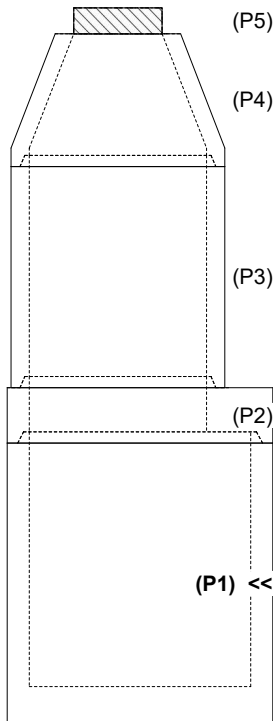

INSIDE WALL DIMENSIONS

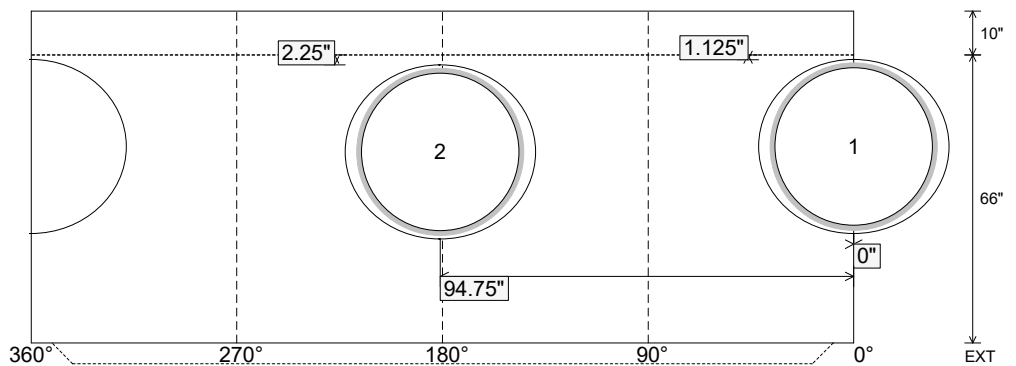

Coating (Int):
 Coating (Ext):

Seam Up: Tongue
 Seam Dn: n/a

Wall Thickness: 6"
 Floor Height: 10"

Height (Int): 66"
 Height (Ext): 76"

Weight (Net): 8952 lb
 Volume (Net): 2.29cu.yd

Job Name: 25-3118 - W6 Ph 2-C Force Main Improvements
 Job Location: Fort Mitchell, KY 41017
 Contractor: Lykins Contracting

Plant: 100

Tech: J. Horsley - A

3/20/2026 1:21:57 PM

PC: Celina Goff



Structure ID: 2301568

P1 MH060BAVF

MH BASE (10"F) Custom Ht T/n

- P5) 24" - CASTING HEIGHT - 7"
- P4) 48" - CON CONE w/24" HOLE F/G - 36"
- P3) 48" - MH RISER T/G - 60"
- P2) 60" - MH Transition Slab 48" Hole T/G - 15"
- P1) 60" - MH BASE (10"F) Custom Ht T/n - 66"
- 1) 60" - MH INVERT CHANNEL - FULL HEIGHT
- 1) 60" - Conseal CS-102 1.00" (Double)
- 2) 48" - Conseal CS-102 1.00" (Double)
- 2) A-Lok - 1235
- 13) MH Step ML-10-TDS-NCR - 10"

0 lb
 2252 lb
 4192 lb
 2204 lb
 8952 lb
 2692 lb
 0 lb
 0 lb
 2 lb
 0 lb

 Structure Total: 20294 lb

Structure Notes:

1. PER ASTM C-478 SPECIFICATIONS
2. CONCRETE: 4,000 PSI AT 28 DAYS
3. REINFORCEMENT:
 - WALLS: PER ASTM A615 - DOUBLE MAT
 - FLOOR: #5 BAR @ 12" C.C. E.W. (GRADE 60) - 2" MIN. REBAR CLEARANCE (TYP)
4. INVERT CHANNEL REQUIRED
5. STEPS AT 270 DEGREES
6. 7" CASTING SUPPLIED BY OTHERS

Rim: 761.59' Rim to Invert: 15.32' Slack: 2.84" Sump: 3" Step Position: 270°

Position	Elev	Angle	Ext. (cw)	Pipe	Pipe OD	Connector	Hole	Horz Size	Up ()	Offset
Invert 1	746.27'	0°	0"	36" PVC SDR35/F679	38.3"	A-Lok 1235	39.88"	43.623"	1.125"	0"
Invert 2	746.37'	181°	113.75"	36" PVC SDR35/F679	38.3"	A-Lok 1235	39.88"	43.623"	2.25"	0"
Invert 3										
Invert 4										
Invert 5										
Invert 6										
Invert 7										
Invert 8										

RIGHT-SIDE UP VIEW (int. dimensions)

UPSIDE-DOWN VIEW (int. dimenions)

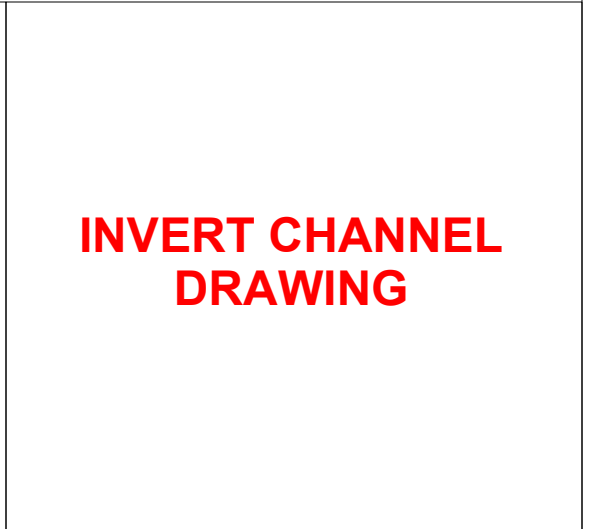
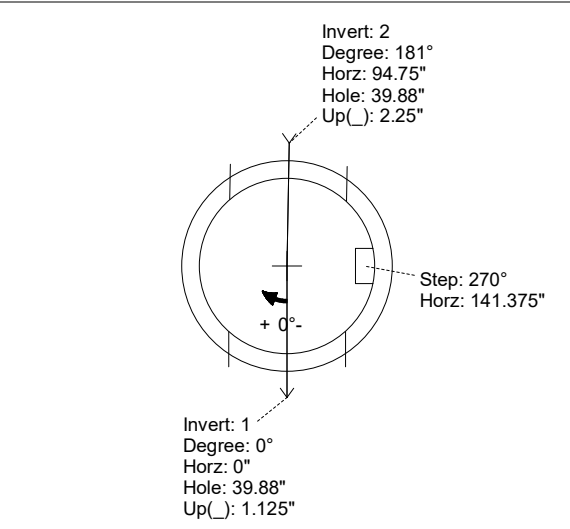
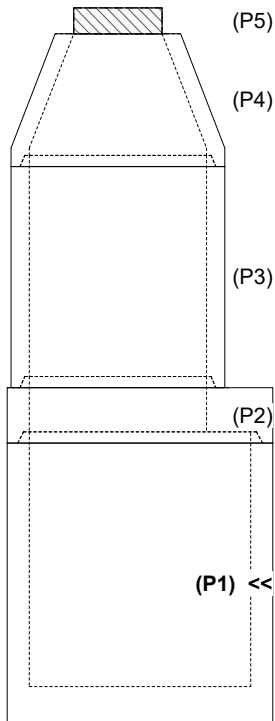

INSIDE WALL DIMENSIONS

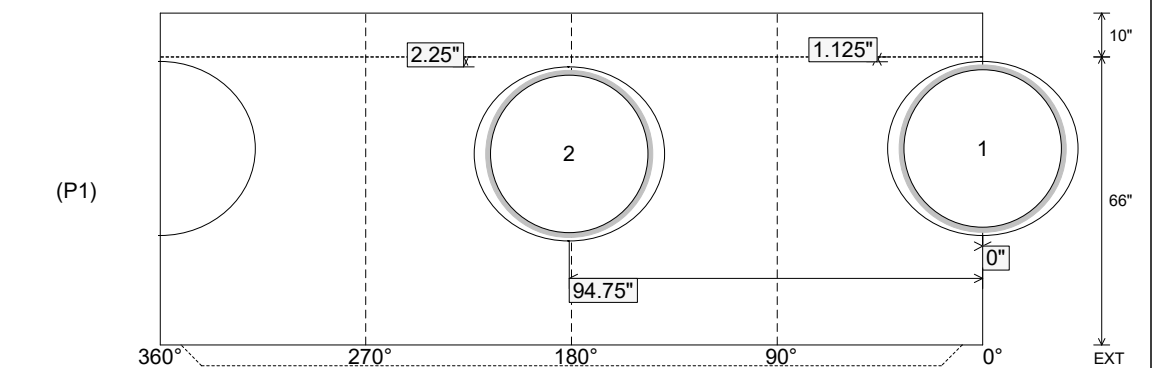

Coating (Int):
 Coating (Ext):

Seam Up: Tongue
 Seam Dn: n/a

Wall Thickness: 6"
 Floor Height: 10"

Height (Int): 66"
 Height (Ext): 76"

Weight (Net): 8952 lb
 Volume (Net): 2.29cu.yd