

Job Name: 25-3118 - W6 Ph 2-C Force Main Improvements
 Job Location: Fort Mitchell, KY 41017
 Contractor: Lykins Contracting

Plant: 100

Tech: J. Horsley - A

3/20/2026 1:21:44 PM

PC: Celina Goff



Structure ID: 2301558

P1 MH072DPVF

MH BASE (10"F) w/DROP Custom Ht T/n

- P6) 24" - CASTING HEIGHT - 7"
- P5) 48" - CON CONE w/24" HOLE F/G - 36"
- P4) 48" - MH RISER T/G - 48"
- P3) 72" - MH Transition Slab 48" Hole T/G - 15"
- P2) 72" - MH RISER w/DROP T/G - 48"
- P1) 72" - MH BASE (10"F) w/DROP Custom Ht T/n - 60"
- 1) 72" - MH INVERT CHANNEL - FULL HEIGHT
- 1) SECONDARY POUR - Add Exterior Drop to Base (P1)
- 1) SECONDARY POUR - Add Exterior Drop to Riser (P2)
- 2) 72" - Conseal CS-102 1.00" (Double)
- 2) 48" - Conseal CS-102 1.00" (Double)
- 2) A-Lok - 1235
- 1) Drop Tee - 8" PVC
- 1) Drop Elbow - 8" PVC
- 17) MH Step ML-10-TDS-NCR - 10"

- 0 lb
- 2252 lb
- 3353 lb
- 3864 lb
- 6964 lb
- 15068 lb
- 5422 lb
- 3010 lb
- 2064 lb
- 0 lb
- 0 lb
- 2 lb
- 0 lb
- 0 lb
- 0 lb
- 0 lb
- 0 lb

- Structure Notes:**
1. PER ASTM C-478 SPECIFICATIONS
 2. CONCRETE: 4,000 PSI AT 28 DAYS
 3. REINFORCEMENT:
 - WALLS: PER ASTM A615 - DOUBLE MAT
 - FLOOR: #5 BAR @ 12" C.C. E.W. (GRADE 60) - 2" MIN. REBAR CLEARANCE (TYP)
 4. INVERT CHANNEL REQUIRED
 5. STEPS AT 270 DEGREES
 6. 7" CASTING SUPPLIED BY OTHERS
 7. EXTERIOR DROP AT INVERTS 2 & 4 SUPPLIED BY ICAST

Structure Total: 42000 lb

FIRST POUR (BASE): 15,068 LBS
SECOND POUR (DROP): 3,010 LBS

Rim: 758.88' Rim to Invert: 17.83' Slack: 2.96" Sump: 3" Step Position: 270°

Position	Elev	Angle	Ext. (cw)	Pipe	Pipe OD	Connector	Hole	Horz Size	Up ()	Offset
Invert 1	741.05'	0°	0"	36" PVC SDR35/F679	38.3"	A-Lok 1235	39.88"	42.266"	1.125"	0"
Invert 2										
Invert 3	741.15'	180°	135.125"	36" PVC SDR35/F679	38.3"	A-Lok 1235	39.88"	42.266"	2.25"	0"
Invert 4	742.85'	117°	87.75"	8" PVC SDR35	8.5"	Drop Elbow 8" PVC	8.5"	8.52"	24.375"	0"
Invert 5										
Invert 6										
Invert 7										
Invert 8										

RIGHT-SIDE UP VIEW (int. dimensions)

UPSIDE-DOWN VIEW (int. dimensions)

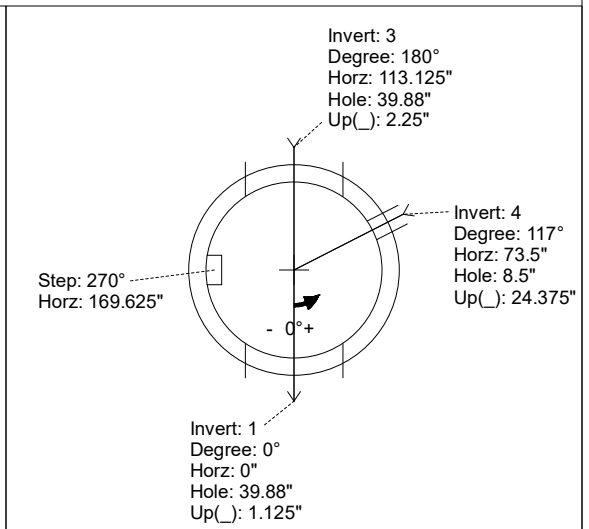
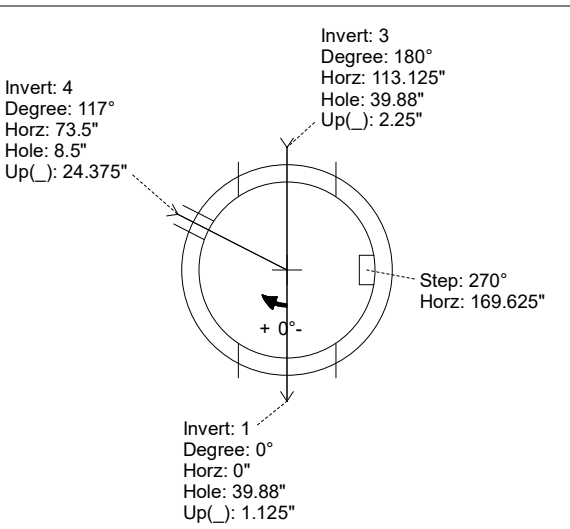

INSIDE WALL DIMENSIONS

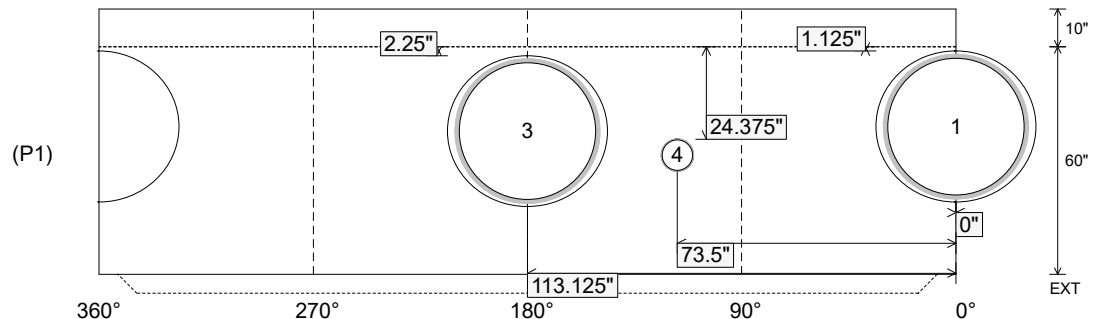

Coating (Int):
Coating (Ext):

Seam Up: Tongue
Seam Dn: n/a

Wall Thickness: 7"
Floor Height: 10"

Height (Int): 60"
Height (Ext): 70"

Weight (Net): 15068 lb
Volume (Net): 3.85cu.yd

Job Name: 25-3118 - W6 Ph 2-C Force Main Improvements
 Job Location: Fort Mitchell, KY 41017
 Contractor: Lykins Contracting

Plant: 100

Tech: J. Horsley - A

3/20/2026 1:21:44 PM

PC: Celina Goff



Structure ID: 2301558

P1 MH072DPVF

MH BASE (10"F) w/DROP Custom Ht T/n

- P6) 24" - CASTING HEIGHT - 7"
- P5) 48" - CON CONE w/24" HOLE F/G - 36"
- P4) 48" - MH RISER T/G - 48"
- P3) 72" - MH Transition Slab 48" Hole T/G - 15"
- P2) 72" - MH RISER w/DROP T/G - 48"
- P1) 72" - MH BASE (10"F) w/DROP Custom Ht T/n - 60"
- 1) 72" - MH INVERT CHANNEL - FULL HEIGHT
- 1) SECONDARY POUR - Add Exterior Drop to Base (P1)
- 1) SECONDARY POUR - Add Exterior Drop to Riser (P2)
- 2) 72" - Conseal CS-102 1.00" (Double)
- 2) 48" - Conseal CS-102 1.00" (Double)
- 2) A-Lok - 1235
- 1) Drop Tee - 8" PVC
- 1) Drop Elbow - 8" PVC
- 17) MH Step ML-10-TDS-NCR - 10"

- 0 lb
- 2252 lb
- 3353 lb
- 3864 lb
- 6964 lb
- 15068 lb
- 5422 lb
- 3010 lb
- 2064 lb
- 0 lb
- 0 lb
- 2 lb
- 0 lb
- 0 lb
- 0 lb
- 0 lb
- 0 lb
-
- Structure Total: 42000 lb

- Structure Notes:**
1. PER ASTM C-478 SPECIFICATIONS
 2. CONCRETE: 4,000 PSI AT 28 DAYS
 3. EXTERIOR DROP REINFORCEMENT: DRILL & STUB #4 BAR @ 12" C.C. E.W. (GRADE 60) - 2" MIN. REBAR CLEARANCE (TYP)
 4. INVERT CHANNEL REQUIRED
 5. STEPS AT 270 DEGREES
 6. 7" CASTING SUPPLIED BY OTHERS
 7. EXTERIOR DROP AT INVERTS 2 & 4 SUPPLIED BY ICAST
 8. ADD 8" SDR 35 DROP & ELBOW AT INVERT 4 (117°)

FIRST POUR (BASE): 15,068 LBS
SECOND POUR (DROP): 3,010 LBS

Rim: 758.88' Rim to Invert: 17.83' Slack: 2.96" Sump: 3" Step Position: 270°

Position	Elev	Angle	Ext. (cw)	Pipe	Pipe OD	Connector	Hole	Horz Size	Up (")	Offset
Invert 1	741.05'	0°	0"	36" PVC SDR35/F679	38.3"	A-Lok 1235	39.88"	42.266"	1.125"	0"
Invert 2										
Invert 3	741.15'	180°	135.125"	36" PVC SDR35/F679	38.3"	A-Lok 1235	39.88"	42.266"	2.25"	0"
Invert 4	742.85'	117°	87.75"	8" PVC SDR35	8.5"	Drop Elbow 8" PVC	8.5"	8.52"	24.375"	0"
Invert 5										
Invert 6										
Invert 7										
Invert 8										

RIGHT-SIDE UP VIEW (int. dimensions)

UPSIDE-DOWN VIEW (int. dimensions)

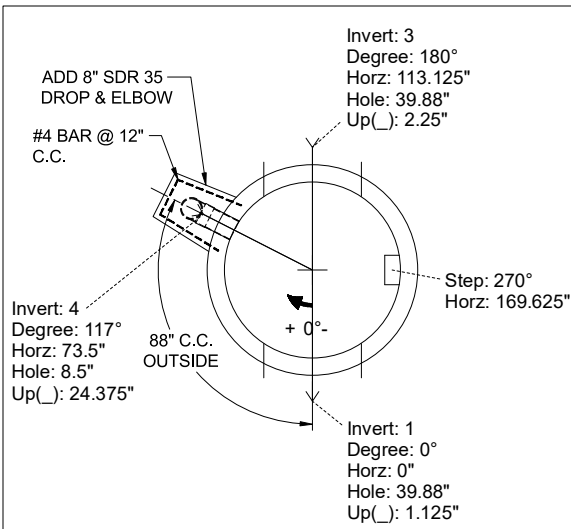
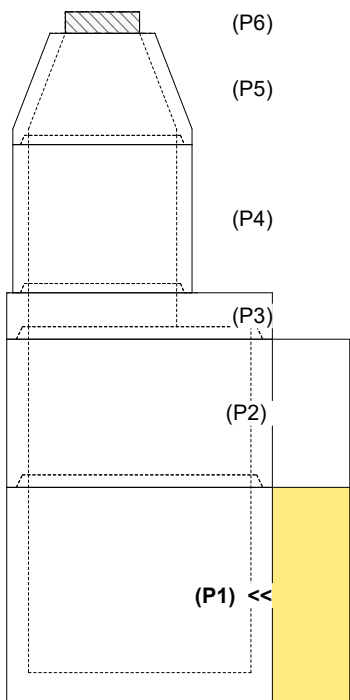

INSIDE WALL DIMENSIONS

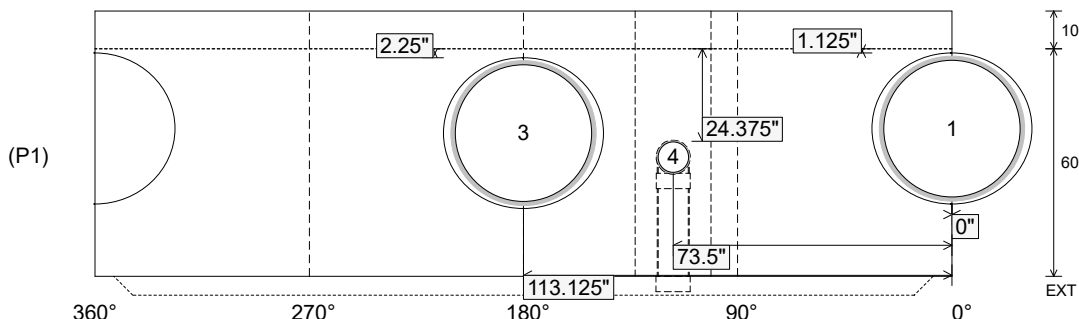

Coating (Int):
 Coating (Ext):

Seam Up: Tongue
 Seam Dn: n/a

Wall Thickness: 7"
 Floor Height: 10"

Height (Int): 60"
 Height (Ext): 70"

Weight (Net): 15068 lb
 Volume (Net): 3.85cu.yd

Job Name: 25-3118 - W6 Ph 2-C Force Main Improvements
 Job Location: Fort Mitchell, KY 41017
 Contractor: Lykins Contracting

Plant: 100

Tech: J. Horsley - A

3/20/2026 1:21:44 PM

PC: Celina Goff



Structure ID: 2301558

P1 MH072DPVF

MH BASE (10" F) w/DROP Custom Ht T/n

P6) 24" - CASTING HEIGHT - 7"	0 lb
P5) 48" - CON CONE w/24" HOLE F/G - 36"	2252 lb
P4) 48" - MH RISER T/G - 48"	3353 lb
P3) 72" - MH Transition Slab 48" Hole T/G - 15"	3864 lb
P2) 72" - MH RISER w/DROP T/G - 48"	6964 lb
P1) 72" - MH BASE (10" F) w/DROP Custom Ht T/n - 60"	15068 lb
1) 72" - MH INVERT CHANNEL - FULL HEIGHT	5422 lb
1) SECONDARY POUR - Add Exterior Drop to Base (P1)	3010 lb
1) SECONDARY POUR - Add Exterior Drop to Riser (P2)	2064 lb
2) 72" - Conseal CS-102 1.00" (Double)	0 lb
2) 48" - Conseal CS-102 1.00" (Double)	0 lb
2) A-Lok - 1235	2 lb
1) Drop Tee - 8" PVC	0 lb
1) Drop Elbow - 8" PVC	0 lb
17) MH Step ML-10-TDS-NCR - 10"	0 lb
Structure Total:	42000 lb

Structure Notes:
 1. PER ASTM C-478 SPECIFICATIONS
 2. CONCRETE: 4,000 PSI AT 28 DAYS
 3. REINFORCEMENT:
 - WALLS: PER ASTM A615 - DOUBLE MAT
 - FLOOR: #5 BAR @ 12" C.C. E.W. (GRADE 60) - 2" MIN. REBAR CLEARANCE (TYP)
 4. INVERT CHANNEL REQUIRED
 5. STEPS AT 270 DEGREES
 6. 7" CASTING SUPPLIED BY OTHERS
 7. EXTERIOR DROP AT INVERTS 2 & 4 SUPPLIED BY ICAST

Rim: 758.88' Rim to Invert: 17.83' Slack: 2.96" Sump: 3" Step Position: 270°

Position	Elev	Angle	Ext. (cw)	Pipe	Pipe OD	Connector	Hole	Horz Size	Up ()	Offset
Invert 1	741.05'	0°	0"	36" PVC SDR35/F679	38.3"	A-Lok 1235	39.88"	42.266"	1.125"	0"
Invert 2										
Invert 3	741.15'	180°	135.125"	36" PVC SDR35/F679	38.3"	A-Lok 1235	39.88"	42.266"	2.25"	0"
Invert 4	742.85'	117°	87.75"	8" PVC SDR35	8.5"	Drop Elbow 8" PVC	8.5"	8.52"	24.375"	0"
Invert 5										
Invert 6										
Invert 7										
Invert 8										

RIGHT-SIDE UP VIEW (int. dimensions)

UPSIDE-DOWN VIEW (int. dimensions)

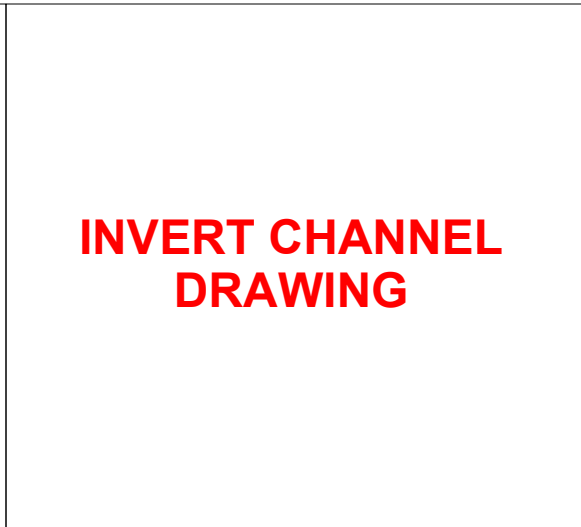
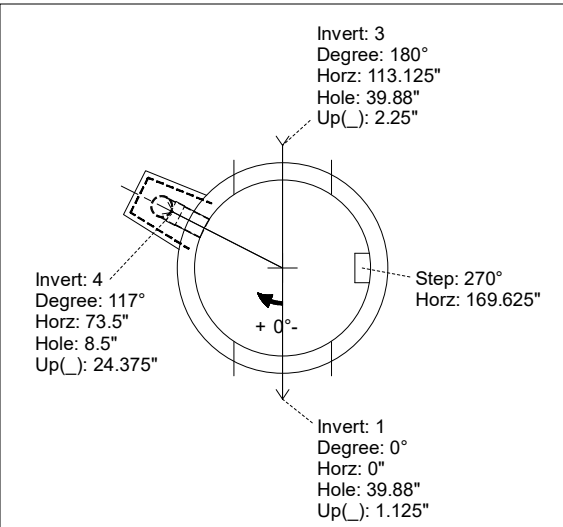
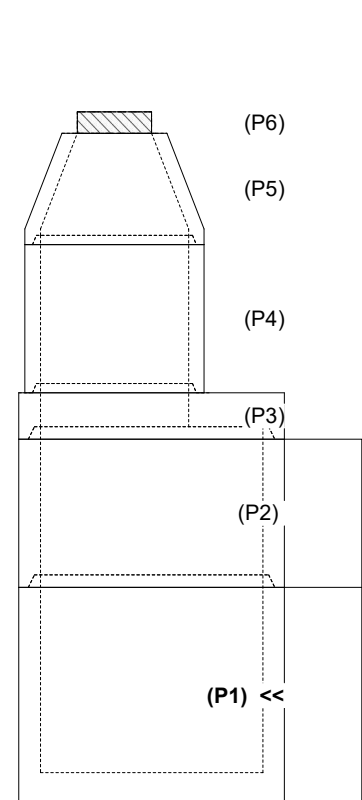

INSIDE WALL DIMENSIONS

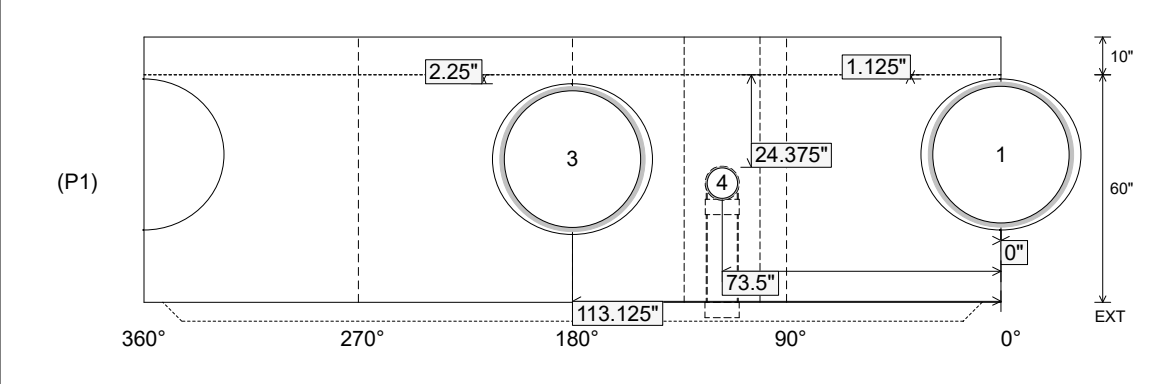

Coating (Int): Coating (Ext):	Seam Up: Tongue Seam Dn: n/a	Wall Thickness: 7" Floor Height: 10"	Height (Int): 60" Height (Ext): 70"	Weight (Net): 15068 lb Volume (Net): 3.85cu.yd
----------------------------------	---------------------------------	---	--	---