

**Job Name: 25-3118 - W6 Ph 2-C Force Main Improvements**  
**Job Location: Fort Mitchell, KY 41017**  
**Contractor: Lykins Contracting**

PC: Celina Goff  
 TECH: J. Horsley - A  
 Plant: 100



Structure ID: **2301553**  
 Spec: Sanitary  
 Type: SAN.MH Transition  
 Size: 60"

Rim: 751.41'  
 Invert: 738.87'  
 Rim to Invert: 12.54'

Sump: 3"  
 Floor (Top): 738.62'  
 Floor Height: 8"

Floor (Bot): 737.953'  
 Overall Height: 13.25'  
 Slack: 2.48"

**Structure Notes:**

- PER ASTM C-478 SPECIFICATIONS
- CONCRETE: 4,000 PSI AT 28 DAYS
- REINFORCEMENT:
  - CONE & RISER: PER ASTM A615
  - TRANSITION SLAB: #5 BAR @ 6" C.C. E.W. (GRADE 60)
  - BASE WALLS: PER ASTM A615 - DOUBLE MAT
  - BASE FLOOR: #5 BAR @ 12" C.C. E.W. (GRADE 60)
- INVERT CHANNEL REQUIRED
- STEPS AT 260 DEGREES
- 7" CASTING SUPPLIED BY OTHERS

**STRUCTURE SUMMARY:**

P5) 24" - CASTING HEIGHT - 7"	0 lb
P4) 48" - CON CONE w/24" HOLE F/G - 24"	2252 lb
P3) 48" - MH RISER T/G - 48"	3353 lb
P2) 60" - MH Transition Slab 48" Hole T/G - 15"	2204 lb
P1) 60" - MH BASE Custom Ht T/n - 57"	7329 lb
1) 60" - MH INVERT CHANNEL - FULL HEIGHT	2692 lb
1) 60" - Conseal CS-102 1.00" (Double)	0 lb
2) 48" - Conseal CS-102 1.00" (Double)	0 lb
2) A-Lok - 1235	2 lb
11) MH Step ML-10-TDS-NCR - 10"	0 lb
<b>Structure Total:</b>	<b>17832 lb</b>

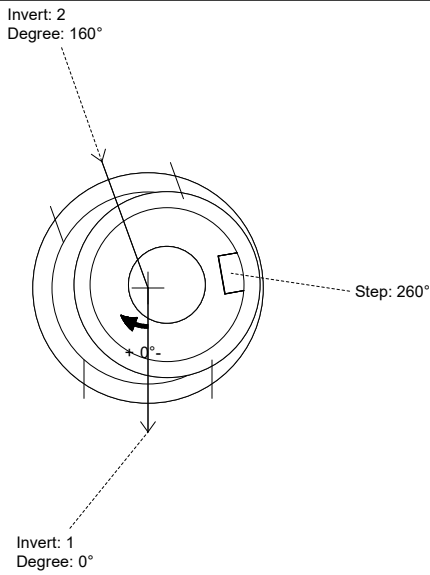

Position	Elev	Angle	Pipe	Pipe OD	Hole	Connector	Up (L)	Ref
Rim	751.41'							
Reducer	743.37'							
Invert 1	738.87'	0°	36" PVC SDR35/F679	38.3"	39.88"	A-Lok 1235	1.125"	P1
Invert 2	738.97'	160°	36" PVC SDR35/F679	38.3"	39.88"	A-Lok 1235	2.25"	P1
Invert 3								
Invert 4								
Invert 5								
Invert 6								
Invert 7								
Invert 8								

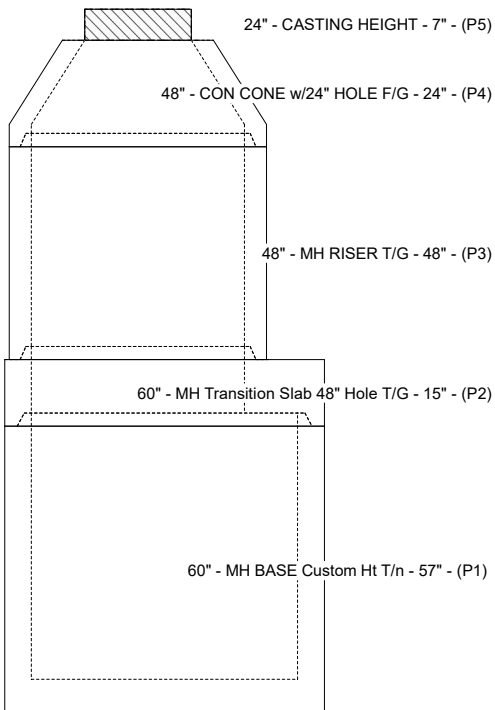

**Cast (Int. Dim.) - Interior Dimensions**

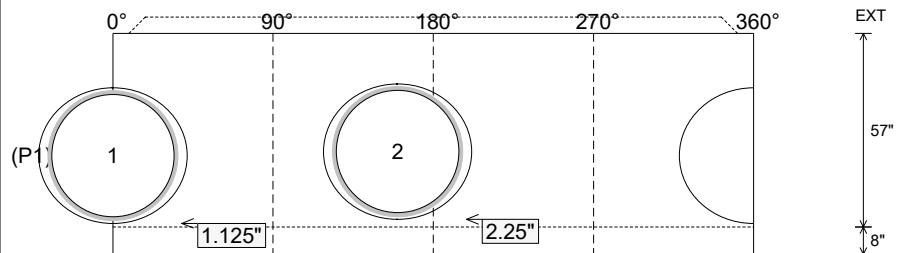

Submittal Drawing  
 3/17/2026 12:35:30 PM

SUBMITTAL  
 APPROVED BY: