

Job Name: 25-3118 - W6 Ph 2-C Force Main Improvements  
 Job Location: Fort Mitchell, KY 41017  
 Contractor: Lykins Contracting

Plant: 100

Tech: J. Horsley - A

3/20/2026 1:21:34 PM

PC: Celina Goff



**Structure ID: 2301551**

**P1 MH060BA72**

**MH BASE T/n**

- P5) 24" - CASTING HEIGHT - 7" 0 lb
- P4) 48" - CON CONE w/24" HOLE F/G - 24" 2252 lb
- P3) 48" - MH RISER T/G - 24" 1677 lb
- P2) 60" - MH Transition Slab 48" Hole T/G - 15" 2204 lb
- P1) 60" - MH BASE T/n - 72" 8895 lb
- 1) 60" - MH INVERT CHANNEL - FULL HEIGHT 2692 lb
- 1) 60" - Conseal CS-102 1.00" (Double) 0 lb
- 2) 48" - Conseal CS-102 1.00" (Double) 0 lb
- 2) A-Lok - 1235 2 lb
- 10) MH Step ML-10-TDS-NCR - 10" 0 lb

Structure Total: 17722 lb

**Structure Notes:**

1. PER ASTM C-478 SPECIFICATIONS
2. CONCRETE: 4,000 PSI AT 28 DAYS
3. REINFORCEMENT:
  - WALLS: PER ASTM A615 - DOUBLE MAT
  - FLOOR: #5 BAR @ 12" C.C. E.W. (GRADE 60) - 2" MIN. REBAR CLEARANCE (TYP)
4. INVERT CHANNEL REQUIRED
5. STEPS AT 90 DEGREES
6. 7" CASTING SUPPLIED BY OTHERS

Rim: 750' Rim to Invert: 11.82' Slack: 2.84" Sump: 3" Step Position: 90°

Position	Elev	Angle	Ext. (cw)	Pipe	Pipe OD	Connector	Hole	Horz Size	Up ( )	Offset
Invert 1	738.18'	0°	0"	36" PVC SDR35/F679	38.3"	A-Lok 1235	39.88"	43.623"	1.125"	0"
Invert 2	738.28'	230°	144.5"	36" PVC SDR35/F679	38.3"	A-Lok 1235	39.88"	43.623"	2.25"	0"
Invert 3										
Invert 4										
Invert 5										
Invert 6										
Invert 7										
Invert 8										

RIGHT-SIDE UP VIEW (int. dimensions)

UPSIDE-DOWN VIEW (int. dimensions)

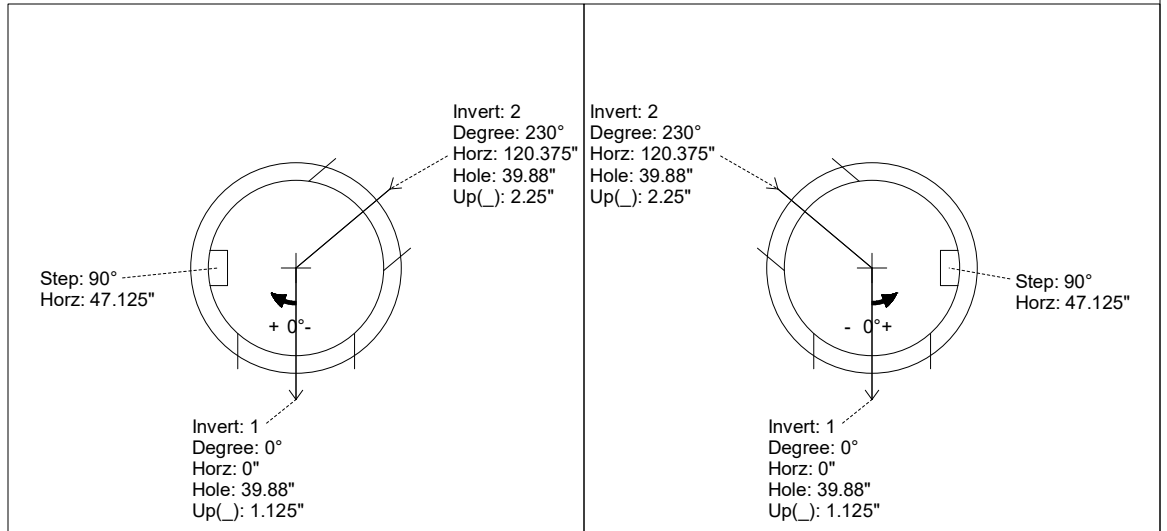
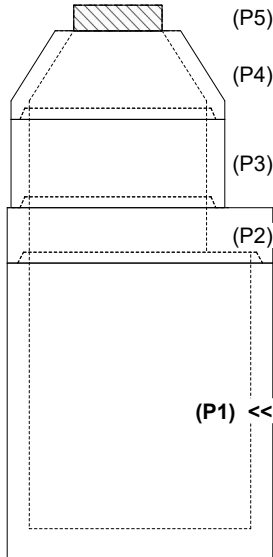

INSIDE WALL DIMENSIONS

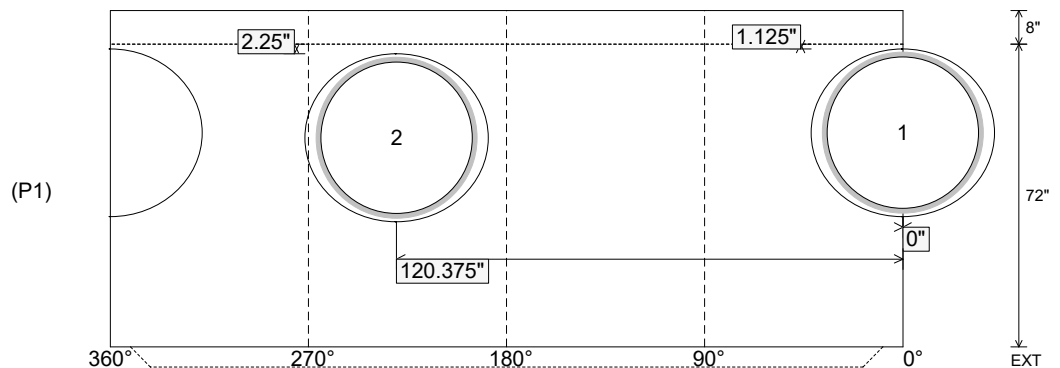

Coating (Int):  
 Coating (Ext):

Seam Up: Tongue  
 Seam Dn: n/a

Wall Thickness: 6"  
 Floor Height: 8"

Height (Int): 72"  
 Height (Ext): 80"

Weight (Net): 8895 lb  
 Volume (Net): 2.27cu.yd

Job Name: 25-3118 - W6 Ph 2-C Force Main Improvements  
 Job Location: Fort Mitchell, KY 41017  
 Contractor: Lykins Contracting

Plant: 100

Tech: J. Horsley - A

3/20/2026 1:21:34 PM

PC: Celina Goff



**Structure ID: 2301551**

**P1 MH060BA72**

**MH BASE T/n**

- P5) 24" - CASTING HEIGHT - 7"
- P4) 48" - CON CONE w/24" HOLE F/G - 24"
- P3) 48" - MH RISER T/G - 24"
- P2) 60" - MH Transition Slab 48" Hole T/G - 15"
- P1) 60" - MH BASE T/n - 72"
- 1) 60" - MH INVERT CHANNEL - FULL HEIGHT
- 1) 60" - Conseal CS-102 1.00" (Double)
- 2) 48" - Conseal CS-102 1.00" (Double)
- 2) A-Lok - 1235
- 10) MH Step ML-10-TDS-NCR - 10"

0 lb  
 2252 lb  
 1677 lb  
 2204 lb  
 8895 lb  
 2692 lb  
 0 lb  
 0 lb  
 2 lb  
 0 lb  
 -----  
 Structure Total: 17722 lb

- Structure Notes:**
1. PER ASTM C-478 SPECIFICATIONS
  2. CONCRETE: 4,000 PSI AT 28 DAYS
  3. REINFORCEMENT:
    - WALLS: PER ASTM A615 - DOUBLE MAT
    - FLOOR: #5 BAR @ 12" C.C. E.W. (GRADE 60) - 2" MIN. REBAR CLEARANCE (TYP)
  4. INVERT CHANNEL REQUIRED
  5. STEPS AT 90 DEGREES
  6. 7" CASTING SUPPLIED BY OTHERS

Rim: 750' Rim to Invert: 11.82' Slack: 2.84" Sump: 3" Step Position: 90°

Position	Elev	Angle	Ext. (cw)	Pipe	Pipe OD	Connector	Hole	Horz Size	Up ( )	Offset
Invert 1	738.18'	0°	0"	36" PVC SDR35/F679	38.3"	A-Lok 1235	39.88"	43.623"	1.125"	0"
Invert 2	738.28'	230°	144.5"	36" PVC SDR35/F679	38.3"	A-Lok 1235	39.88"	43.623"	2.25"	0"
Invert 3										
Invert 4										
Invert 5										
Invert 6										
Invert 7										
Invert 8										

RIGHT-SIDE UP VIEW (int. dimensions)

UPSIDE-DOWN VIEW (int. dimensions)

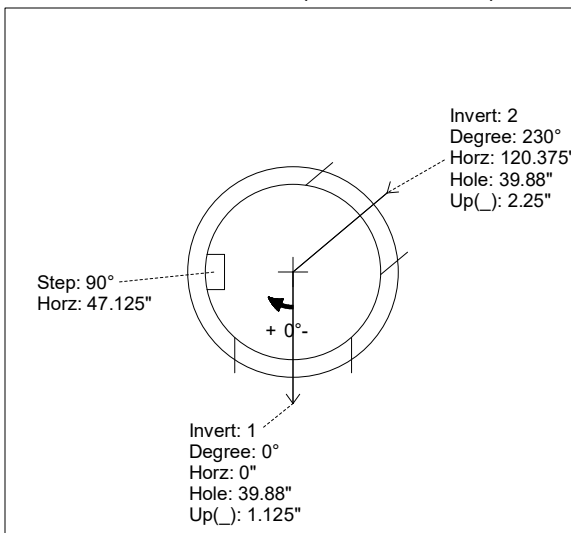
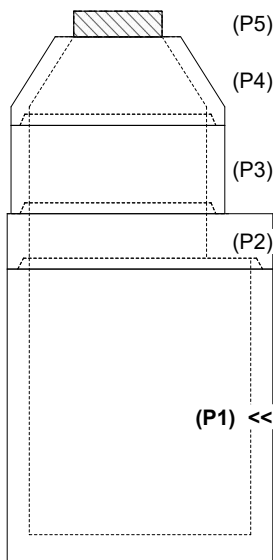

**INVERT CHANNEL DRAWING**

INSIDE WALL DIMENSIONS

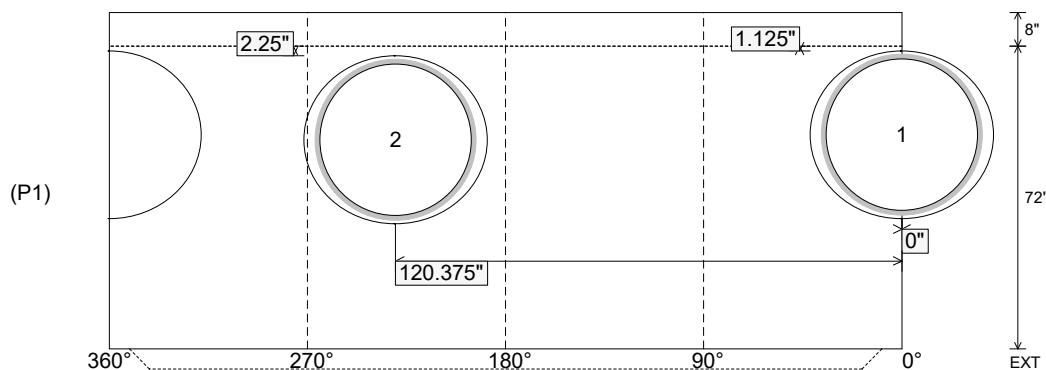

Coating (Int):  
 Coating (Ext):

Seam Up: Tongue  
 Seam Dn: n/a

Wall Thickness: 6"  
 Floor Height: 8"

Height (Int): 72"  
 Height (Ext): 80"

Weight (Net): 8895 lb  
 Volume (Net): 2.27cu.yd