

Job Name: 25-3118 - W6 Ph 2-C Force Main Improvements
 Job Location: Fort Mitchell, KY 41017
 Contractor: Lykins Contracting

Plant: 100

Tech: J. Horsley - A

3/20/2026 1:21:33 PM

PC: Celina Goff



Structure ID: 2301550

P1 MH060BAVF

MH BASE (10"F) Custom Ht T/n

- P5) 24" - CASTING HEIGHT - 7"
- P4) 48" - CON CONE w/24" HOLE F/G - 36"
- P3) 48" - MH RISER T/G - 72"
- P2) 60" - MH Transition Slab 48" Hole T/G - 15"
- P1) 60" - MH BASE (10"F) Custom Ht T/n - 65"
- 1) 60" - MH INVERT CHANNEL - FULL HEIGHT
- 1) 60" - Conseal CS-102 1.00" (Double)
- 2) 48" - Conseal CS-102 1.00" (Double)
- 2) A-Lok - 1235
- 14) MH Step ML-10-TDS-NCR - 10"

0 lb
 2252 lb
 5030 lb
 2204 lb
 8848 lb
 2692 lb
 0 lb
 0 lb
 2 lb
 0 lb

 Structure Total: 21028 lb

Structure Notes:

1. PER ASTM C-478 SPECIFICATIONS
2. CONCRETE: 4,000 PSI AT 28 DAYS
3. REINFORCEMENT:
 - WALLS: PER ASTM A615 - DOUBLE MAT
 - FLOOR: #5 BAR @ 12" C.C. E.W. (GRADE 60) - 2" MIN. REBAR CLEARANCE (TYP)
4. INVERT CHANNEL REQUIRED
5. STEPS AT 270 DEGREES
6. 7" CASTING SUPPLIED BY OTHERS

Rim: 753.64' Rim to Invert: 16.19' Slack: 2.28" Sump: 3" Step Position: 270°

Position	Elev	Angle	Ext. (cw)	Pipe	Pipe OD	Connector	Hole	Horz Size	Up ()	Offset
Invert 1	737.45'	0°	0"	36" PVC SDR35/F679	38.3"	A-Lok 1235	39.88"	43.623"	1.125"	0"
Invert 2	737.55'	156°	98"	36" PVC SDR35/F679	38.3"	A-Lok 1235	39.88"	43.623"	2.25"	0"
Invert 3										
Invert 4										
Invert 5										
Invert 6										
Invert 7										
Invert 8										

RIGHT-SIDE UP VIEW (int. dimensions)

UPSIDE-DOWN VIEW (int. dimensions)

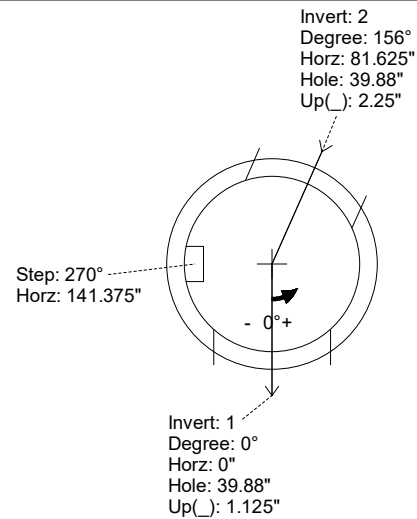
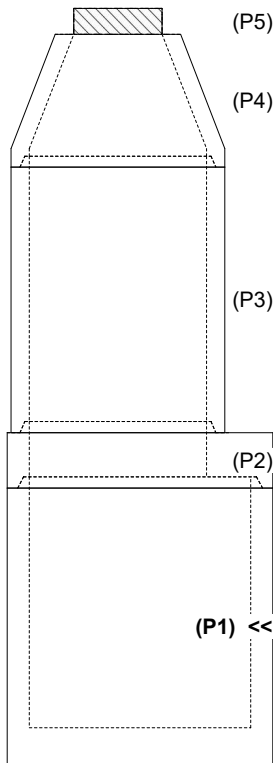

INSIDE WALL DIMENSIONS

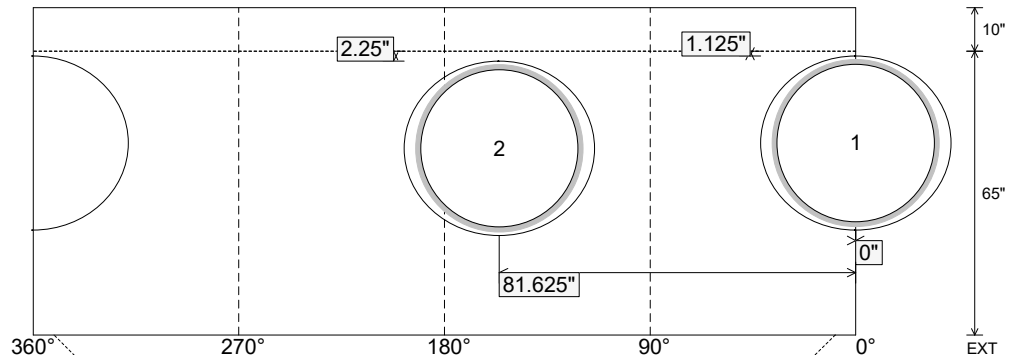

Coating (Int):
 Coating (Ext):

Seam Up: Tongue
 Seam Dn: n/a

Wall Thickness: 6"
 Floor Height: 10"

Height (Int): 65"
 Height (Ext): 75"

Weight (Net): 8848 lb
 Volume (Net): 2.26cu.yd

Structure ID: 2301550

P1 MH060BAVF

MH BASE (10"F) Custom Ht T/n

P5) 24" - CASTING HEIGHT - 7" P4) 48" - CON CONE w/24" HOLE F/G - 36" P3) 48" - MH RISER T/G - 72" P2) 60" - MH Transition Slab 48" Hole T/G - 15" P1) 60" - MH BASE (10"F) Custom Ht T/n - 65" 1) 60" - MH INVERT CHANNEL - FULL HEIGHT 1) 60" - Conseal CS-102 1.00" (Double) 2) 48" - Conseal CS-102 1.00" (Double) 2) A-Lok - 1235 14) MH Step ML-10-TDS-NCR - 10"	0 lb 2252 lb 5030 lb 2204 lb 8848 lb 2692 lb 0 lb 0 lb 2 lb 0 lb ----- Structure Total: 21028 lb
---	---

Structure Notes:

1. PER ASTM C-478 SPECIFICATIONS
2. CONCRETE: 4,000 PSI AT 28 DAYS
3. REINFORCEMENT:
 - WALLS: PER ASTM A615 - DOUBLE MAT
 - FLOOR: #5 BAR @ 12" C.C. E.W. (GRADE 60) - 2" MIN. REBAR CLEARANCE (TYP)
4. INVERT CHANNEL REQUIRED
5. STEPS AT 270 DEGREES
6. 7" CASTING SUPPLIED BY OTHERS

Rim: 753.64' Rim to Invert: 16.19' Slack: 2.28" Sump: 3" Step Position: 270°

Position	Elev	Angle	Ext. (cw)	Pipe	Pipe OD	Connector	Hole	Horz Size	Up ()	Offset
Invert 1	737.45'	0°	0"	36" PVC SDR35/F679	38.3"	A-Lok 1235	39.88"	43.623"	1.125"	0"
Invert 2	737.55'	156°	98"	36" PVC SDR35/F679	38.3"	A-Lok 1235	39.88"	43.623"	2.25"	0"
Invert 3										
Invert 4										
Invert 5										
Invert 6										
Invert 7										
Invert 8										

RIGHT-SIDE UP VIEW (int. dimensions)

UPSIDE-DOWN VIEW (int. dimensions)

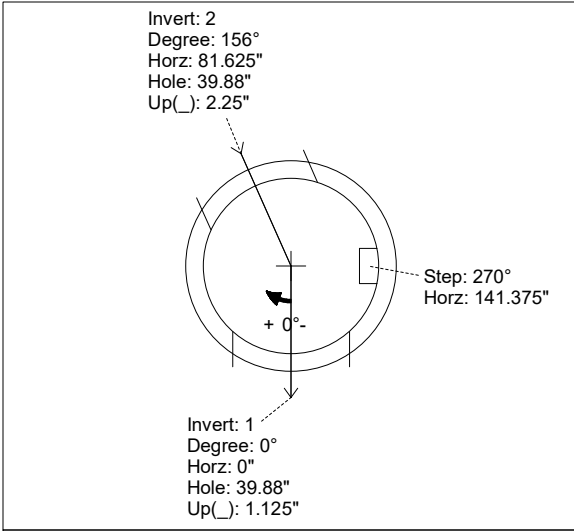
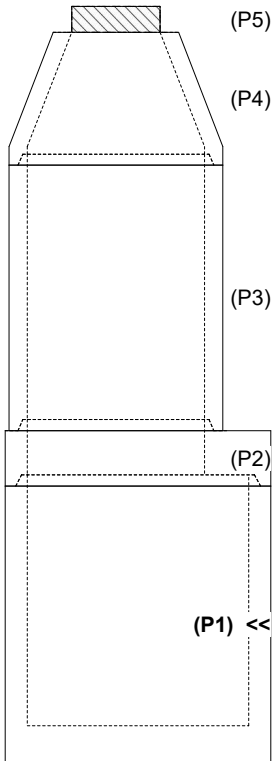

INVERT CHANNEL DRAWING

INSIDE WALL DIMENSIONS

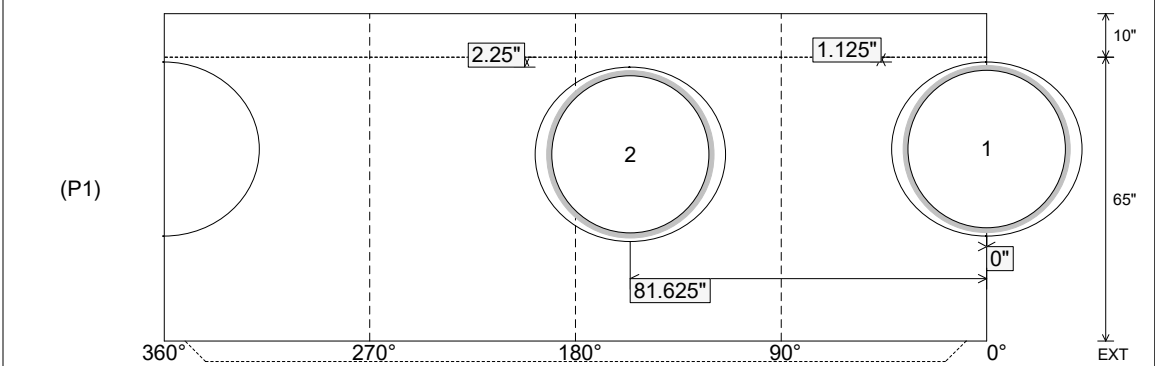

Coating (Int): Coating (Ext):	Seam Up: Tongue Seam Dn: n/a	Wall Thickness: 6" Floor Height: 10"	Height (Int): 65" Height (Ext): 75"	Weight (Net): 8848 lb Volume (Net): 2.26cu.yd
----------------------------------	---------------------------------	---	--	--