

Job Name: 25-3118 - W6 Ph 2-C Force Main Improvements
 Job Location: Fort Mitchell, KY 41017
 Contractor: Lykins Contracting

Plant: 100

Tech: J. Horsley - A

3/27/2026 11:40:03 AM

PC: Celina Goff



Structure ID: 2301546

P4 MH048CCN36

CON CONE w/24" HOLE F/G

P6) 24" - CASTING HEIGHT - 7"	0 lb
P5) 24" - GRADE RING F/F - 3"	202 lb
P4) 48" - CON CONE w/24" HOLE F/G - 36"	2252 lb
P3) 72" - MH Transition Slab 48" Hole T/G - 15"	3864 lb
P2) 72" - MH RISER w/DROP T/G - 60"	8713 lb
P1) 72" - MH BASE w/DROP T/n - 60"	11072 lb
1) 72" - MH INVERT CHANNEL - FULL HEIGHT	5422 lb
1) SECONDARY POUR - Add Exterior Drop to Base (P1)	2924 lb
1) SECONDARY POUR - Add Exterior Drop to Riser (P2)	2580 lb
2) 72" - Conseal CS-102 1.00" (Double)	0 lb
1) 48" - Conseal CS-102 1.00" (Double)	0 lb
2) A-Lok - 1235	2 lb
1) Drop Tee - 8" PVC	0 lb
1) Drop Elbow - 8" PVC	0 lb
14) MH Step ML-10-TDS-NCR - 10"	0 lb

Structure Total:	37033 lb

Structure Notes:
 1. PER ASTM C-478 SPECIFICATIONS
 2. CONCRETE: 4,000 PSI AT 28 DAYS
 3. REINFORCEMENT: PER ASTM A615
 4. STEPS REQUIRED
 5. 7" CASTING SUPPLIED BY OTHERS

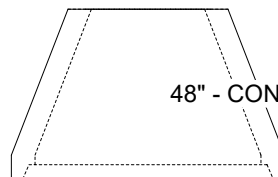
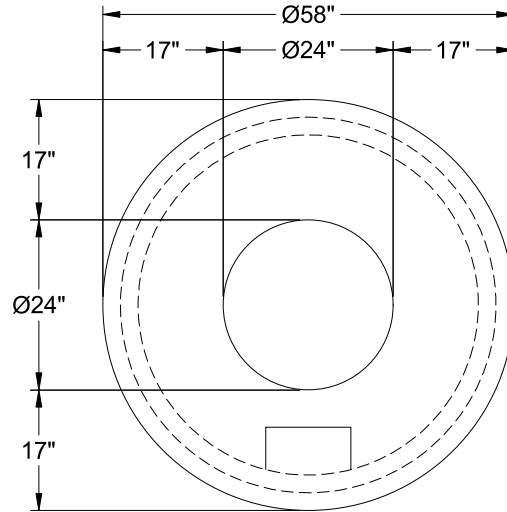

48" - CON CONE w/24" HOLE F/G - 36" - (P4)

Coating (Int): Coating (Ext):	Seam Up: Flat Seam Dn: Groove	Wall Thickness: 5"	Height (Ext): 36"	Weight (Net): 2252 lb Volume (Net): 0.57cu.yd
----------------------------------	----------------------------------	--------------------	-------------------	--