

Job Name: 25-3118 - W6 Ph 2-C Force Main Improvements
 Job Location: Fort Mitchell, KY 41017
 Contractor: Lykins Contracting

Plant: 100

3/27/2026 11:39:53 AM

Tech: J. Horsley - A

PC: Celina Goff



Structure ID: 2301542

P5 MH048CCN24

CON CONE w/24" HOLE F/G

P6) 24" - CASTING HEIGHT - 7"	0 lb
P5) 48" - CON CONE w/24" HOLE F/G - 24"	2252 lb
P4) 48" - MH RISER T/G - 48"	3353 lb
P3) 60" - MH Transition Slab 48" Hole T/G - 15"	2204 lb
P2) 60" - MH RISER w/DROP T/G - 60"	6235 lb
P1) 60" - MH BASE (10"F) w/DROP Custom Ht T/n - 59"	11159 lb
1) 60" - MH INVERT CHANNEL - FULL HEIGHT	2692 lb
1) SECONDARY POUR - Add Exterior Drop to Base (P1)	2967 lb
1) SECONDARY POUR - Add Exterior Drop to Riser (P2)	2580 lb
2) 60" - Conseal CS-102 1.00" (Double)	0 lb
2) 48" - Conseal CS-102 1.00" (Double)	0 lb
2) A-Lok - 1235	2 lb
1) Drop Tee - 8" PVC	0 lb
1) Drop Elbow - 8" PVC	0 lb
16) MH Step ML-10-TDS-NCR - 10"	0 lb

Structure Total:	33444 lb

Structure Notes:
 1. PER ASTM C-478 SPECIFICATIONS
 2. CONCRETE: 4,000 PSI AT 28 DAYS
 3. REINFORCEMENT: PER ASTM A615
 4. STEPS REQUIRED
 5. 7" CASTING SUPPLIED BY OTHERS

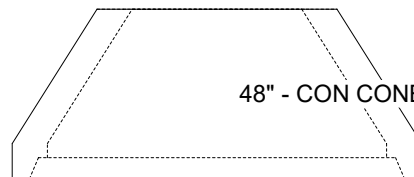
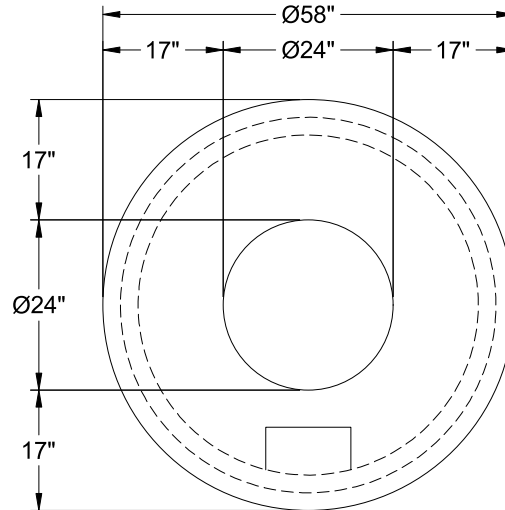

48" - CON CONE w/24" HOLE F/G - 24" - (P5)

Coating (Int):
 Coating (Ext):

Seam Up: Flat
 Seam Dn: Groove

Wall Thickness: 5"

Height (Ext): 24"

Weight (Net): 2252 lb
 Volume (Net): 0.57cu.yd