

Job Name: 25-3118 - W6 Ph 2-C Force Main Improvements
Job Location: Fort Mitchell, KY 41017
Contractor: Lykins Contracting

PC: Celina Goff
 TECH: J. Horsley - A
 Plant: 100



Structure ID: **2301538**
 Spec: Sanitary
 Type: SAN.MH Transition w/Ext. Drop
 Size: 60"

Rim: 762.81'
 Invert: 732.84'
 Rim to Invert: 29.97'

Sump: 3"
 Floor (Top): 732.59'
 Floor Height: 14"

Floor (Bot): 731.423'
 Overall Height: 31.167'
 Slack: 2.64"

- Structure Notes:**
- PER ASTM C-478 SPECIFICATIONS
 - CONCRETE: 4,000 PSI AT 28 DAYS
 - REINFORCEMENT:
 - CONE & RISERS: PER ASTM A615
 - TRANSITION SLAB: #5 BAR @ 6" C.C. E.W. (GRADE 60)
 - BASE WALLS: PER ASTM A615 - DOUBLE MAT
 - BASE FLOOR: #5 BAR @ 12" C.C. E.W. (GRADE 60)
 - INVERT CHANNEL REQUIRED
 - STEPS AT 200 DEGREES
 - 7" CASTING SUPPLIED BY OTHERS
 - EXTERIOR DROP AT INVERTS 3 & 4 SUPPLIED BY ICAST

STRUCTURE SUMMARY:

P8) 24" - CASTING HEIGHT - 7"	0 lb
P7) 48" - CON CONE w/24" HOLE F/G - 24"	2252 lb
P6) 48" - MH RISER T/G - 72"	5030 lb
P5) 48" - MH RISER T/G - 72"	5030 lb
P4) 60" - MH Transition Slab 48" Hole T/G - 15"	2204 lb
P3) 60" - MH RISER w/DROP T/G - 60"	6235 lb
P2) 60" - MH RISER w/DROP Custom Ht T/G - 38"	3967 lb
P1) 60" - MH BASE (14"F) w/DROP Custom Ht T/n - 72"	14615 lb
1) 60" - MH INVERT CHANNEL - FULL HEIGHT	2692 lb
1) SECONDARY POUR - Add Exterior Drop to Base (P1)	3698 lb
1) SECONDARY POUR - Add Exterior Drop to Riser (P2)	1634 lb
1) SECONDARY POUR - Add Exterior Drop to Riser (P3)	2580 lb
3) 60" - Conseal CS-102 1.00" (Double)	0 lb
3) 48" - Conseal CS-102 1.00" (Double)	0 lb
2) A-Lok - 1235	2 lb
1) Drop Tee - 8" PVC	0 lb
1) Drop Elbow - 8" PVC	0 lb
28) MH Step ML-10-TDS-NCR - 10"	0 lb
Structure Total:	49939 lb

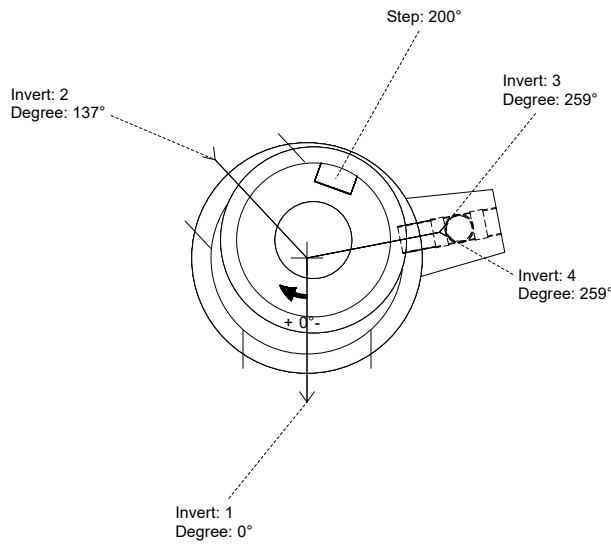

Position	Elev	Angle	Pipe	Pipe OD	Hole	Connector	Up (')	Ref
Rim	762.81'							
Reducer	746.757'							
Invert 1	732.84'	0°	36" PVC SDR35/F679	38.3"	39.88"	A-Lok 1235	1.125"	P1
Invert 2	732.94'	137°	36" PVC SDR35/F679	38.3"	39.88"	A-Lok 1235	2.25"	P1
Invert 3	744.93'	259°	8" PVC SDR35	8.5"	8.5"	Drop Tee 8" PVC	33.125"	P3
Invert 4	734.64'	259°	8" PVC SDR35	8.5"	8.5"	Drop Elbow 8" PVC	24.375"	P1
Invert 5								
Invert 6								
Invert 7								
Invert 8								

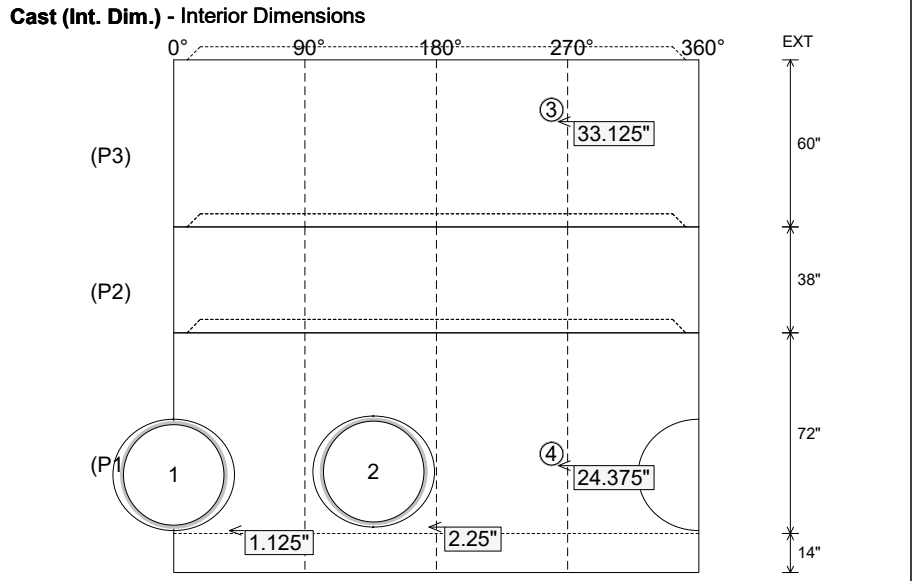
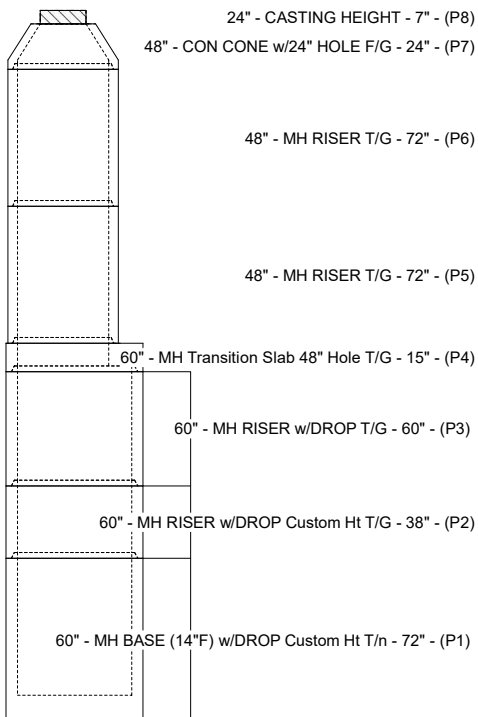

Submittal Drawing
 3/17/2026 12:34:59 PM

SUBMITTAL
 APPROVED BY: