

Job Name: 25-3118 - W6 Ph 2-C Force Main Improvements
 Job Location: Fort Mitchell, KY 41017
 Contractor: Lykins Contracting

Plant: 100

Tech: J. Horsley - A

3/26/2026 2:14:25 PM

PC: Celina Goff



Structure ID: 2301538

P3 MH060R60

MH RISER w/DROP T/G

- P8) 24" - CASTING HEIGHT - 7"
- P7) 48" - CON CONE w/24" HOLE F/G - 24"
- P6) 48" - MH RISER T/G - 72"
- P5) 48" - MH RISER T/G - 72"
- P4) 60" - MH Transition Slab 48" Hole T/G - 15"
- P3) 60" - MH RISER w/DROP T/G - 60"
- P2) 60" - MH RISER w/DROP Custom Ht T/G - 38"
- P1) 60" - MH BASE (14"F) w/DROP Custom Ht T/n - 72"
- 1) 60" - MH INVERT CHANNEL - FULL HEIGHT
- 1) SECONDARY POUR - Add Exterior Drop to Base (P1)
- 1) SECONDARY POUR - Add Exterior Drop to Riser (P2)
- 1) SECONDARY POUR - Add Exterior Drop to Riser (P3)
- 3) 60" - Conseal CS-102 1.00" (Double)
- 3) 48" - Conseal CS-102 1.00" (Double)
- 2) A-Lok - 1235
- 1) Drop Tee - 8" PVC
- 1) Drop Elbow - 8" PVC
- 28) MH Step ML-10-TDS-NCR - 10"

- 0 lb
- 2252 lb
- 5030 lb
- 5030 lb
- 2204 lb
- 6235 lb
- 3967 lb
- 14615 lb
- 2692 lb
- 3698 lb
- 1634 lb
- 2580 lb
- 0 lb
- 0 lb
- 2 lb
- 0 lb
- 0 lb
- 0 lb

Structure Notes:
 1. PER ASTM C-478 SPECIFICATIONS
 2. CONCRETE: 4,000 PSI AT 28 DAYS
 3. REINFORCEMENT: PER ASTM A615
 4. STEPS AT 200 DEGREES
 5. 7" CASTING SUPPLIED BY OTHERS
 6. EXTERIOR DROP AT INVERTS 3 & 4 SUPPLIED BY ICAST

Structure Total: 49939 lb

FIRST POUR (RISER): 6,235 LBS
SECOND POUR (DROP): 2,580 LBS

Rim: 762.81' Rim to Invert: 29.97' Slack: 2.64" Sump: 3" Step Position: 200°

| Position | Elev | Angle | Ext. (cw) | Pipe | Pipe OD | Connector | Hole | Horz Size | Up () | Offset |
|----------|---------|-------|-----------|--------------|---------|-----------------|------|-----------|---------|--------|
| Invert 1 | | | | | | | | | | |
| Invert 2 | | | | | | | | | | |
| Invert 3 | 744.93' | 259° | 162.75" | 8" PVC SDR35 | 8.5" | Drop Tee 8" PVC | 8.5" | 8.529" | 33.125" | 0" |
| Invert 4 | | | | | | | | | | |
| Invert 5 | | | | | | | | | | |
| Invert 6 | | | | | | | | | | |
| Invert 7 | | | | | | | | | | |
| Invert 8 | | | | | | | | | | |

RIGHT-SIDE UP VIEW (int. dimensions)

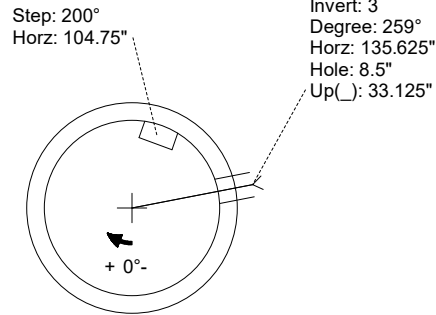
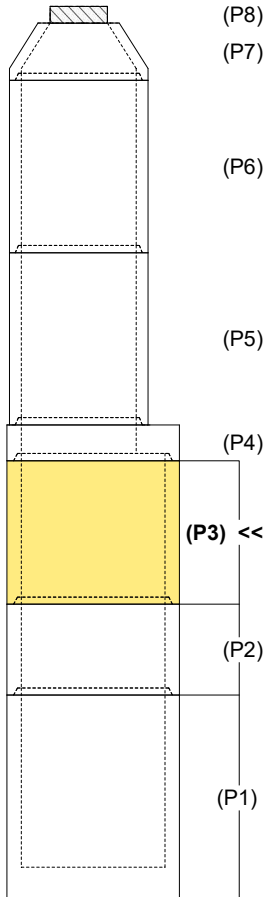

INSIDE WALL DIMENSIONS

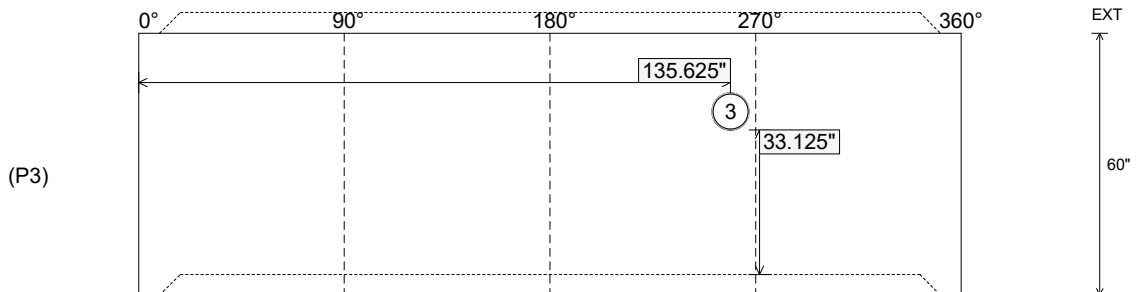

Coating (Int):
 Coating (Ext):

Seam Up: Tongue
 Seam Dn: Groove

Wall Thickness: 6"
 Floor Height: 0"

Height (Int): 60"
 Height (Ext): 60"

Weight (Net): 6235 lb
 Volume (Net): 1.59cu.yd

Job Name: 25-3118 - W6 Ph 2-C Force Main Improvements
 Job Location: Fort Mitchell, KY 41017
 Contractor: Lykins Contracting

Plant: 100

Tech: J. Horsley - A

3/26/2026 2:14:25 PM

PC: Celina Goff



Structure ID: 2301538

P3 MH060R60

MH RISER w/DROP T/G

- P8) 24" - CASTING HEIGHT - 7"
- P7) 48" - CON CONE w/24" HOLE F/G - 24"
- P6) 48" - MH RISER T/G - 72"
- P5) 48" - MH RISER T/G - 72"
- P4) 60" - MH Transition Slab 48" Hole T/G - 15"
- P3) 60" - MH RISER w/DROP T/G - 60"
- P2) 60" - MH RISER w/DROP Custom Ht T/G - 38"
- P1) 60" - MH BASE (14"F) w/DROP Custom Ht T/n - 72"
- 1) 60" - MH INVERT CHANNEL - FULL HEIGHT
- 1) SECONDARY POUR - Add Exterior Drop to Base (P1)
- 1) SECONDARY POUR - Add Exterior Drop to Riser (P2)
- 1) SECONDARY POUR - Add Exterior Drop to Riser (P3)
- 3) 60" - Conseal CS-102 1.00" (Double)
- 3) 48" - Conseal CS-102 1.00" (Double)
- 2) A-Lok - 1235
- 1) Drop Tee - 8" PVC
- 1) Drop Elbow - 8" PVC
- 28) MH Step ML-10-TDS-NCR - 10"

- 0 lb
- 2252 lb
- 5030 lb
- 5030 lb
- 2204 lb
- 6235 lb
- 3967 lb
- 14615 lb
- 2692 lb
- 3698 lb
- 1634 lb
- 2580 lb
- 0 lb
- 0 lb
- 2 lb
- 0 lb
- 0 lb
- 0 lb
- 0 lb

Structure Notes:

1. PER ASTM C-478 SPECIFICATIONS
2. CONCRETE: 4,000 PSI AT 28 DAYS
3. EXTERIOR DROP REINFORCEMENT: DRILL & STUB #4 BAR @ 12" C.C. E.W. (GRADE 60) - 2" MIN. REBAR CLEARANCE (TYP)
4. STEPS AT 200 DEGREES
5. 7" CASTING SUPPLIED BY OTHERS
6. EXTERIOR DROP AT INVERTS 3 & 4 SUPPLIED BY ICAST
7. ADD 8" SDR 35 DROP & TEE AT INVERT 3 (259°)

Structure Total: 49939 lb

FIRST POUR (RISER): 6,235 LBS
SECOND POUR (DROP): 2,580 LBS

Rim: 762.81' Rim to Invert: 29.97' Slack: 2.64" Sump: 3" Step Position: 200°

| Position | Elev | Angle | Ext. (cw) | Pipe | Pipe OD | Connector | Hole | Horz Size | Up () | Offset |
|----------|---------|-------|-----------|--------------|---------|-----------------|------|-----------|---------|--------|
| Invert 1 | | | | | | | | | | |
| Invert 2 | | | | | | | | | | |
| Invert 3 | 744.93' | 259° | 162.75" | 8" PVC SDR35 | 8.5" | Drop Tee 8" PVC | 8.5" | 8.529" | 33.125" | 0" |
| Invert 4 | | | | | | | | | | |
| Invert 5 | | | | | | | | | | |
| Invert 6 | | | | | | | | | | |
| Invert 7 | | | | | | | | | | |
| Invert 8 | | | | | | | | | | |

RIGHT-SIDE UP VIEW (int. dimensions)

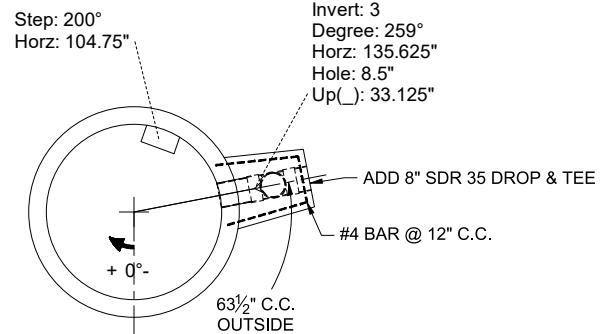
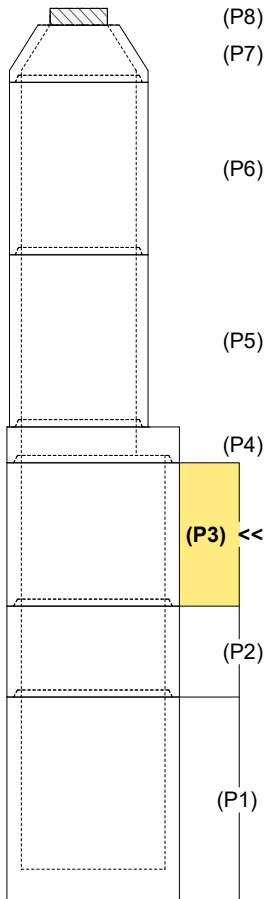

INSIDE WALL DIMENSIONS

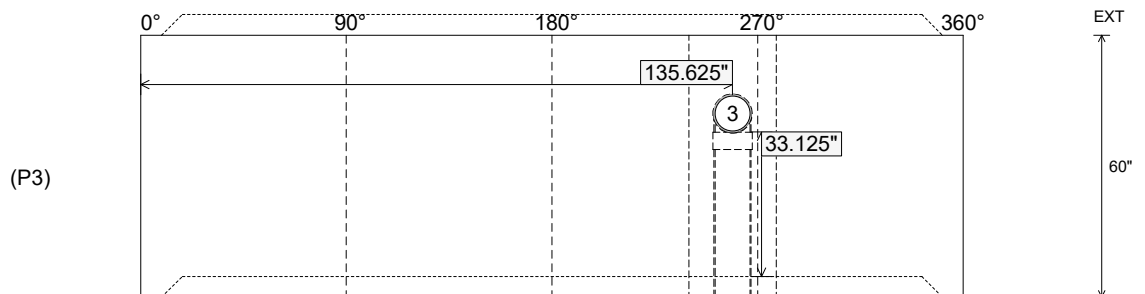

Coating (Int):
Coating (Ext):

Seam Up: Tongue
Seam Dn: Groove

Wall Thickness: 6"
Floor Height: 0"

Height (Int): 60"
Height (Ext): 60"

Weight (Net): 6235 lb
Volume (Net): 1.59cu.yd