

Job Name: 25-3118 - W6 Ph 2-C Force Main Improvements
Job Location: Fort Mitchell, KY 41017
Contractor: Lykins Contracting

PC: Celina Goff
 TECH: J. Horsley - A
 Plant: 100



Structure ID: **2280824**
 Spec: Sanitary
 Type: SAN.MH
 Size: 48"

Rim: 772.69'
 Invert: 764.96'
 Rim to Invert: 7.73'

Sump: 2.309"
 Floor (Top): 764.768"
 Floor Height: 8"

Floor (Bot): 764.101'
 Overall Height: 8.417'
 Slack: 2.069"

- Structure Notes:**
- PER ASTM C-478 SPECIFICATIONS
 - CONCRETE: 4,000 PSI AT 28 DAYS
 - REINFORCEMENT:
 - CONE: PER ASTM A615
 - BASE WALLS: PER ASTM A615 - DOUBLE MAT
 - BASE FLOOR: #5 BAR @ 12" C.C. E.W. (GRADE 60)
 - INVERT CHANNEL REQUIRED
 - STEPS AT 90 DEGREES
 - 7" CASTING SUPPLIED BY OTHERS

STRUCTURE SUMMARY:

P3) 24" - CASTING HEIGHT - 7"	0 lb
P2) 48" - CON CONE w/24" HOLE F/G - 36"	2252 lb
P1) 48" - MH BASE (08"F) T/n - 50"	4829 lb
1) 48" - MH INVERT CHANNEL - FULL HEIGHT	1440 lb
1) 48" - Conseal CS-102 1.00" (Double)	0 lb
1) Kor-N-Seal2 - S206-28	6 lb
1) Kor-N-Seal2 - S206-22	6 lb
5) MH Step ML-10-TDS-NCR - 10"	0 lb
Structure Total:	8535 lb

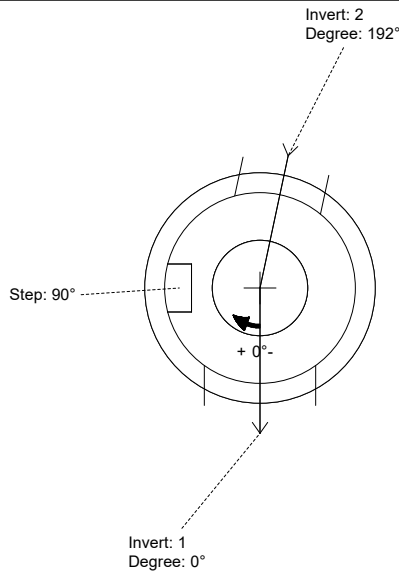

Position	Elev	Angle	Pipe	Pipe OD	Hole	Connector	Up (L)	Ref
Rim	772.69'							
Reducer								
Invert 1	764.96'	0°	24" PVC SDR35/F679	24.803"	28"	Kor-N-Seal2 S206-28	0"	P1
Invert 2	765.86'	192°	18" PVC SDR35	18.75"	22"	Kor-N-Seal2 S206-22	11.125"	P1
Invert 3								
Invert 4								
Invert 5								
Invert 6								
Invert 7								
Invert 8								

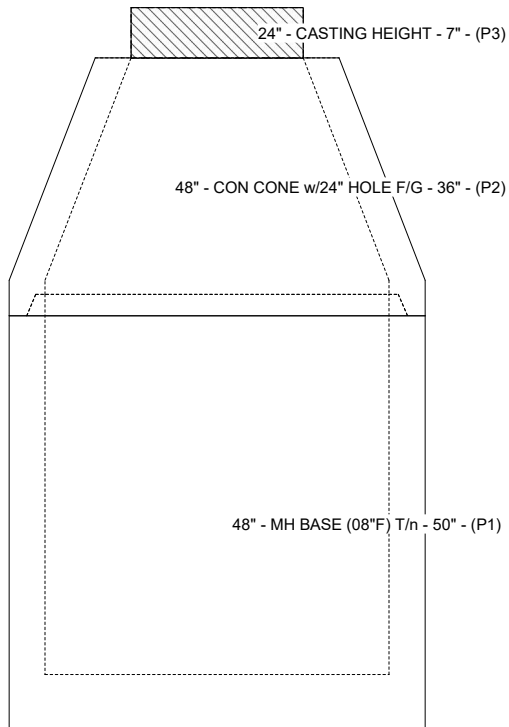

Cast (Int. Dim.) - Interior Dimensions

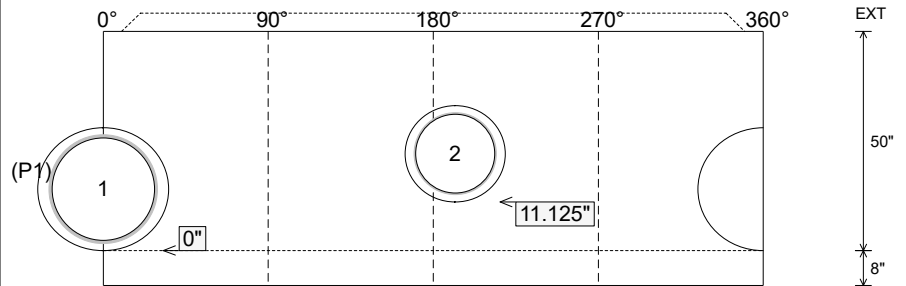

Submittal Drawing
 3/17/2026 12:36:29 PM

SUBMITTAL
 APPROVED BY: