

Job Name: 25-3118 - W6 Ph 2-C Force Main Improvements
 Job Location: Fort Mitchell, KY 41017
 Contractor: Lykins Contracting

Plant: 100

Tech: J. Horsley - A

3/20/2026 1:22:11 PM

PC: Celina Goff



Structure ID: 2280819

P1 MH048BAVF

MH BASE (08"F) T/n

- P4) 24" - CASTING HEIGHT - 7"
- P3) 48" - CON CONE w/24" HOLE F/G - 36"
- P2) 48" - MH RISER T/G - 60"
- P1) 48" - MH BASE (08"F) T/n - 47"
- 1) 48" - MH INVERT CHANNEL - FULL HEIGHT
- 2) 48" - Conseal CS-102 1.00" (Double)
- 2) Kor-N-Seal2 - S206-28
- 10) MH Step ML-10-TDS-NCR - 10"

	0 lb
	2252 lb
	4192 lb
	4512 lb
	1440 lb
	0 lb
	13 lb
	0 lb
Structure Total:	12408 lb

- Structure Notes:**
1. PER ASTM C-478 SPECIFICATIONS
 2. CONCRETE: 4,000 PSI AT 28 DAYS
 3. REINFORCEMENT:
 - WALLS: PER ASTM A615 - DOUBLE MAT
 - FLOOR: #5 BAR @ 12" C.C. E.W. (GRADE 60) - 2" MIN. REBAR CLEARANCE (TYP)
 4. INVERT CHANNEL REQUIRED
 5. STEPS AT 270 DEGREES
 6. 7" CASTING SUPPLIED BY OTHERS

Rim: 773.94' Rim to Invert: 12.51' Slack: 2.43" Sump: 2.31" Step Position: 270°

Position	Elev	Angle	Ext. (cw)	Pipe	Pipe OD	Connector	Hole	Horz Size	Up ()	Offset
Invert 1	761.43'	0°	0"	24" PVC SDR35/F679	24.803"	Kor-N-Seal2 S206-28	28"	29.896"	0"	0"
Invert 2	761.53'	198°	100.25"	24" PVC SDR35/F679	24.803"	Kor-N-Seal2 S206-28	28"	29.896"	1.25"	0"
Invert 3										
Invert 4										
Invert 5										
Invert 6										
Invert 7										
Invert 8										

RIGHT-SIDE UP VIEW (int. dimensions)

UPSIDE-DOWN VIEW (int. dimensions)

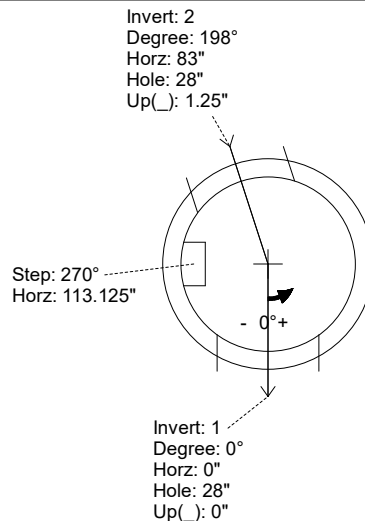
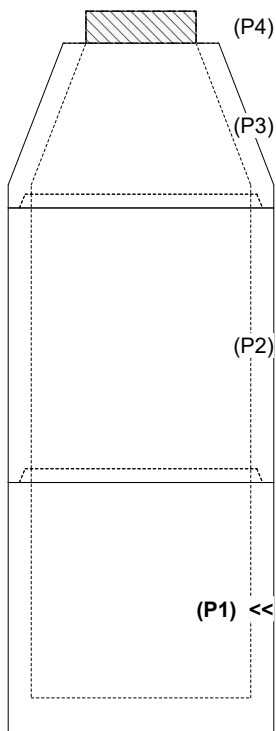

INSIDE WALL DIMENSIONS

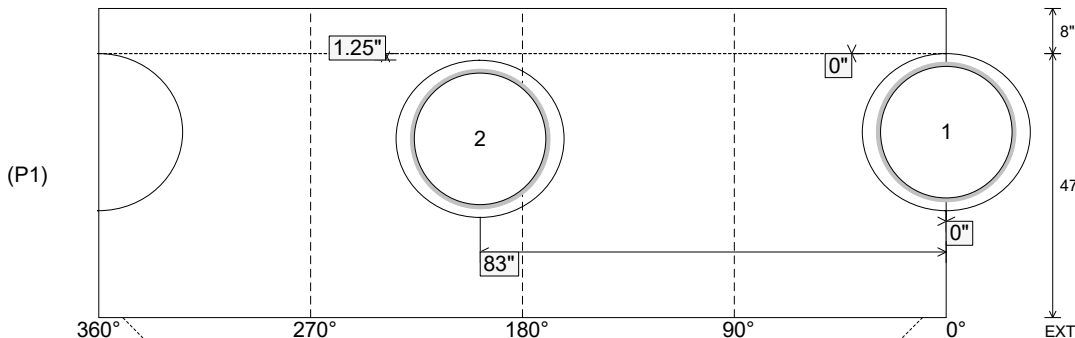

Coating (Int):
Coating (Ext):

Seam Up: Tongue
Seam Dn: n/a

Wall Thickness: 5"
Floor Height: 8"

Height (Int): 47"
Height (Ext): 55"

Weight (Net): 4512 lb
Volume (Net): 1.15cu.yd

Job Name: 25-3118 - W6 Ph 2-C Force Main Improvements
 Job Location: Fort Mitchell, KY 41017
 Contractor: Lykins Contracting

Plant: 100

3/20/2026 1:22:11 PM

Tech: J. Horsley - A

PC: Celina Goff

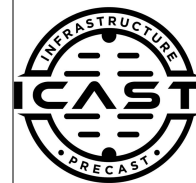

Structure ID: 2280819

P1 MH048BAVF

MH BASE (08"F) T/n

- P4) 24" - CASTING HEIGHT - 7"
- P3) 48" - CON CONE w/24" HOLE F/G - 36"
- P2) 48" - MH RISER T/G - 60"
- P1) 48" - MH BASE (08"F) T/n - 47"
- 1) 48" - MH INVERT CHANNEL - FULL HEIGHT
- 2) 48" - Conseal CS-102 1.00" (Double)
- 2) Kor-N-Seal2 - S206-28
- 10) MH Step ML-10-TDS-NCR - 10"

	0 lb
	2252 lb
	4192 lb
	4512 lb
	1440 lb
	0 lb
	13 lb
	0 lb
Structure Total:	12408 lb

- Structure Notes:**
1. PER ASTM C-478 SPECIFICATIONS
 2. CONCRETE: 4,000 PSI AT 28 DAYS
 3. REINFORCEMENT:
 - WALLS: PER ASTM A615 - DOUBLE MAT
 - FLOOR: #5 BAR @ 12" C.C. E.W. (GRADE 60) - 2" MIN. REBAR CLEARANCE (TYP)
 4. INVERT CHANNEL REQUIRED
 5. STEPS AT 270 DEGREES
 6. 7" CASTING SUPPLIED BY OTHERS

Rim: 773.94' Rim to Invert: 12.51' Slack: 2.43" Sump: 2.31" Step Position: 270°

Position	Elev	Angle	Ext. (cw)	Pipe	Pipe OD	Connector	Hole	Horz Size	Up ()	Offset
Invert 1	761.43'	0°	0"	24" PVC SDR35/F679	24.803"	Kor-N-Seal2 S206-28	28"	29.896"	0"	0"
Invert 2	761.53'	198°	100.25"	24" PVC SDR35/F679	24.803"	Kor-N-Seal2 S206-28	28"	29.896"	1.25"	0"
Invert 3										
Invert 4										
Invert 5										
Invert 6										
Invert 7										
Invert 8										

RIGHT-SIDE UP VIEW (int. dimensions)

UPSIDE-DOWN VIEW (int. dimenions)

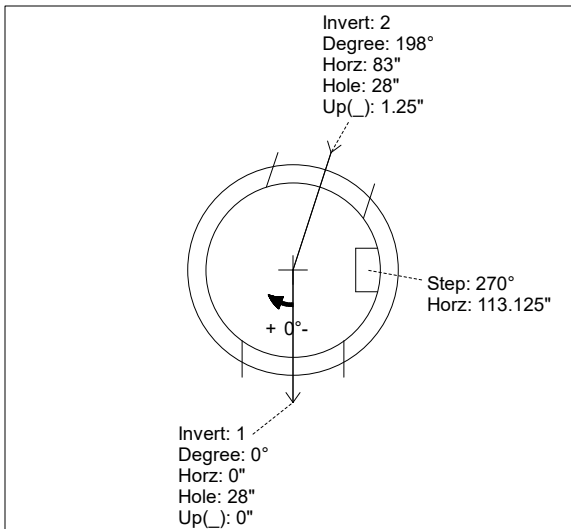
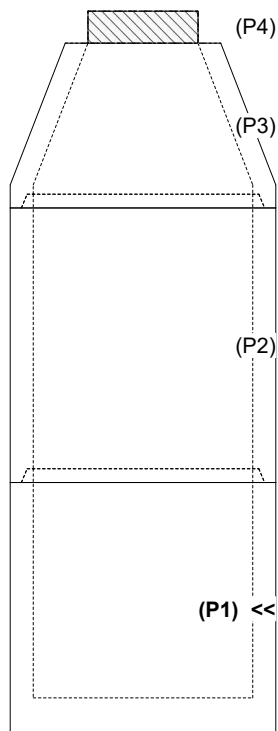

INVERT CHANNEL
DRAWING

INSIDE WALL DIMENSIONS

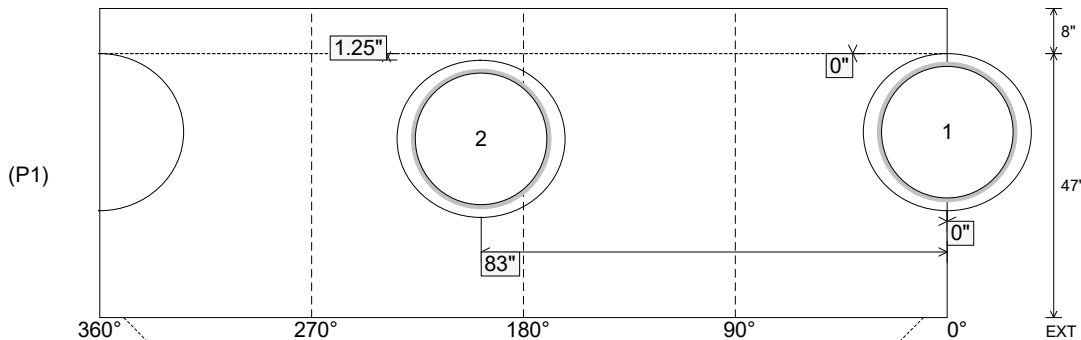

Coating (Int):
Coating (Ext):

Seam Up: Tongue
Seam Dn: n/a

Wall Thickness: 5"
Floor Height: 8"

Height (Int): 47"
Height (Ext): 55"

Weight (Net): 4512 lb
Volume (Net): 1.15cu.yd