

Job Name: 25-3118 - W6 Ph 2-C Force Main Improvements
Job Location: Fort Mitchell, KY 41017
Contractor: Lykins Contracting

PC: Celina Goff
 TECH: J. Horsley - A
 Plant: 100



Structure ID: **1750295**
 Spec: Sanitary
 Type: SAN.MH
 Size: 48"

Rim: 766.35'
 Invert: 757.28'
 Rim to Invert: 9.07'

Sump: 2"
 Floor (Top): 757.113'
 Floor Height: 8"

Floor (Bot): 756.446'
 Overall Height: 9.75'
 Slack: 1.84"

Structure Notes:

1. PER ASTM C-478 SPECIFICATIONS
2. CONCRETE: 4,000 PSI AT 28 DAYS
3. REINFORCEMENT:
 - CONE & RISER: PER ASTM A615
 - BASE WALLS: PER ASTM A615 - DOUBLE MAT
 - BASE FLOOR: #5 BAR @ 12" C.C. E.W. (GRADE 60)
4. INVERT CHANNEL REQUIRED
5. STEPS AT 270 DEGREES
6. 7" CASTING SUPPLIED BY OTHERS

STRUCTURE SUMMARY:

P4) 24" - CASTING HEIGHT - 7"	0 lb
P3) 48" - CON CONE w/24" HOLE F/G - 36"	2252 lb
P2) 48" - MH RISER T/G - 36"	2515 lb
P1) 48" - MH BASE (08"F) T/n - 30"	3651 lb
1) 48" - MH INVERT CHANNEL - FULL HEIGHT	1440 lb
2) 48" - Conseal CS-102 1.00" (Double)	0 lb
2) Kor-N-Seal2 - S206-18L	12 lb
7) MH Step ML-10-TDS-NCR - 10"	0 lb
Structure Total:	9871 lb

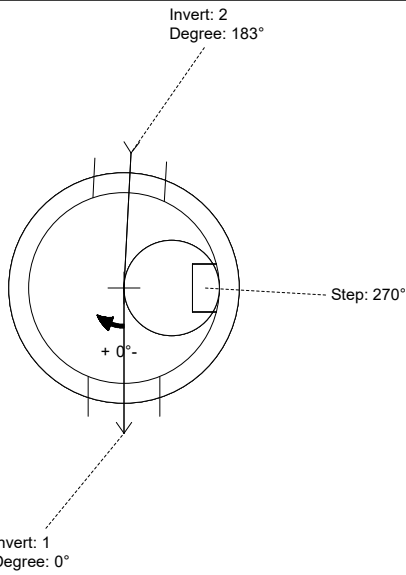

Position	Elev	Angle	Pipe	Pipe OD	Hole	Connector	Up (")	Ref
Rim	766.35'							
Reducer								
Invert 1	757.28'	0°	15" PVC SDR35	15.3"	18"	Kor-N-Seal2 S206-18L	0.5"	P1
Invert 2	757.38'	183°	15" PVC SDR35	15.3"	18"	Kor-N-Seal2 S206-18L	1.75"	P1
Invert 3								
Invert 4								
Invert 5								
Invert 6								
Invert 7								
Invert 8								

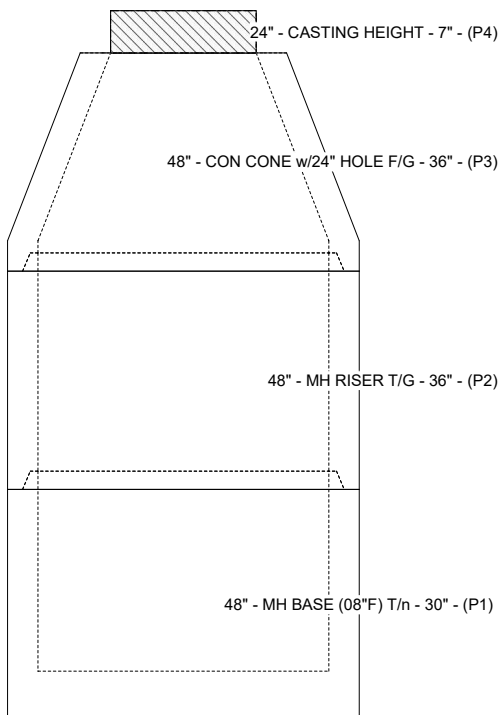

Cast (Int. Dim.) - Interior Dimensions

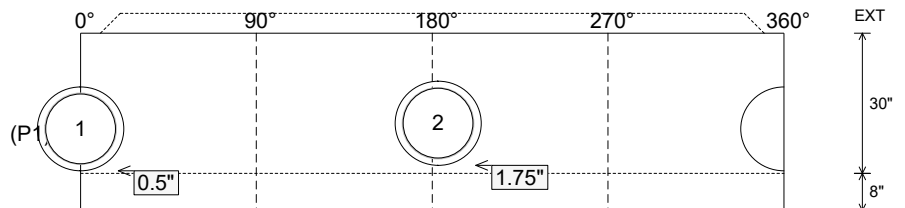

Submittal Drawing
 3/17/2026 12:36:42 PM

SUBMITTAL
 APPROVED BY: