

Job Name: 25-3101 - WF Clari Park
 Job Location: Murfreesboro, TN
 Contractor: Hayes Pipe Supply

Plant: 100
 4/14/2026 6:48:56 PM

Tech: Jared - F
 PC: E. Bradley



Structure ID: A2

P1 MH048BAVF

MH BASE Custom Ht F/n

- P3) 20" x 34" - CASTING HEIGHT - 7"
- P2) 48" - MH FLAT TOP - TDOT NO 10 (20"x34" Hole) F/F - 10"
- P1) 48" - MH BASE Custom Ht F/n - 65"
- 1) 48" - Conseal CS-102 1.00"
- 3) Hole - 22"

0 lb
 1646 lb
 5377 lb
 0 lb
 0 lb

 Structure Total: 7024 lb

- Structure Notes:**
1. PER TDOT D-CB-10RA / ASTM C478 SPEC'S.
 2. CONCRETE = 4,000 PSI AT 28 DAYS.
 3. CASTING BY OTHERS (JBS 3123 MODIFIED SET).

REINFORCING PER ASTM A615 (GRADE 60).
 ** PER TDOT STD DRAWING D-CB-10RA **
 - TOP SLAB - DBL MAT #5 BARS.
 - RISER (As .24)
 - FLOOR (As .62) #5 BARS AT 6" C.C.E.W.

Rim: 591.48' Rim to Invert: 6.66' Slack: 0.17" Sump: 2.25" Step Position:

Position	Elev	Angle	Ext. (cw)	Pipe	Pipe OD	Connector	Hole	Horz Size	Up ()	Offset
Invert 1	584.82'	0°	0"	15" RCP B WALL	19.5"	Hole 22	22"	22.854"	0"	0"
Invert 2	586.74'	145°	73.375"	15" RCP B WALL	19.5"	Hole 22	22"	22.854"	23"	0"
Invert 3	586.74'	225°	113.875"	15" RCP B WALL	19.5"	Hole 22	22"	22.854"	23"	0"
Invert 4										
Invert 5										
Invert 6										
Invert 7										
Invert 8										

RIGHT-SIDE UP VIEW (int. dimensions)

UPSIDE-DOWN VIEW (int. dimensions)

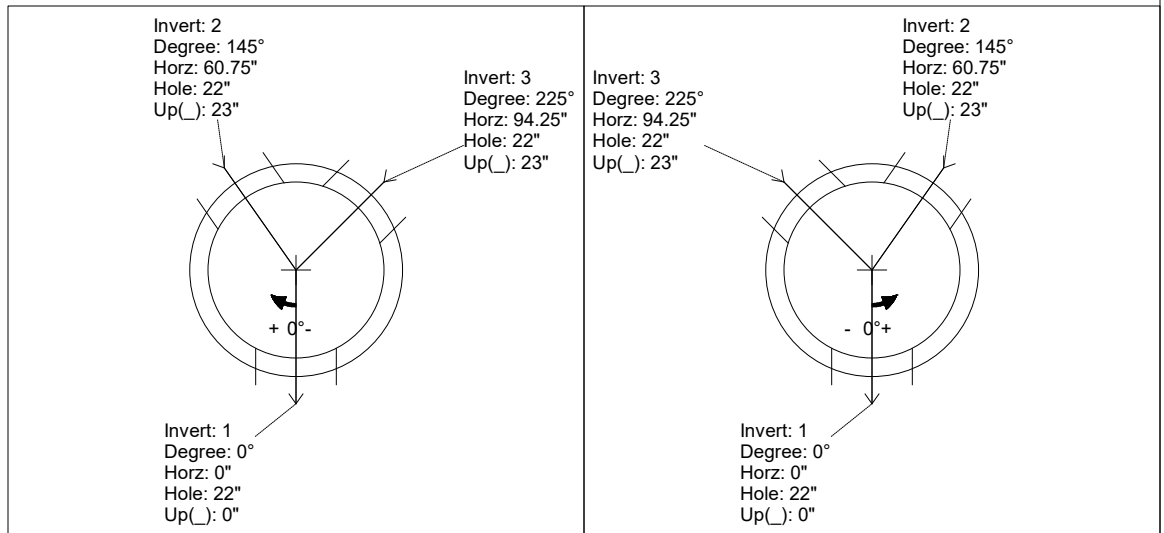
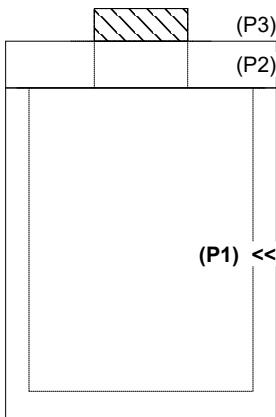

INSIDE WALL DIMENSIONS

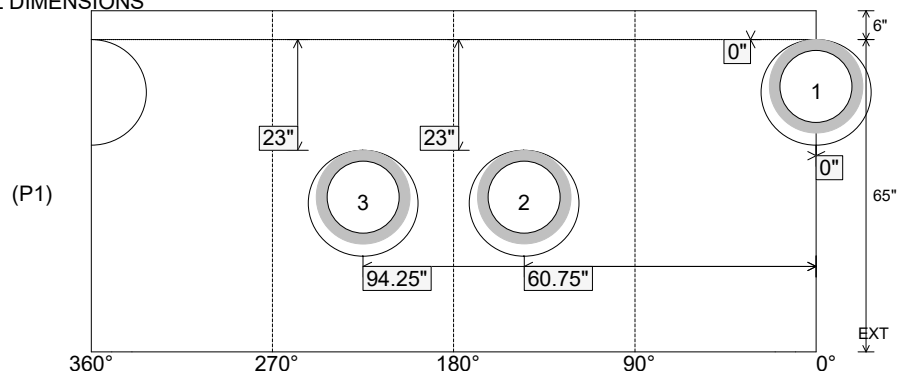

Coating (Int):
 Coating (Ext):

Seam Up: Flat
 Seam Dn: n/a

Wall Thickness: 5"
 Floor Height: 6"

Height (Int): 65"
 Height (Ext): 71"

Weight (Net): 5377 lb
 Volume (Net): 1.37cu.yd