

TOP VIEW

- NOTES:**
1. MANUFACTURED TO ASTM C-1577-16.
 2. COVER DEPTH = 1'
 3. CONCRETE: 5,000 PSI AT 28 DAYS.
 4. REINFORCING: SHALL FOLLOW THE DESIGN PROVIDED BY AAC ENGINEERING, PLLC AND SHALL CONFORM TO ASTM A615, 60 KSI.
 5. BOX CULVERT TO BE SEALED WITH CS-102 ROLL BUTYL MASTIC & CS-212 12" WRAP. (SUPPLIED BY ICAST).
 6. WEIGHT: 72" X 24" X 60" = 9,022 LBS. EA.
 7. TWO TOTAL REQUIRED.

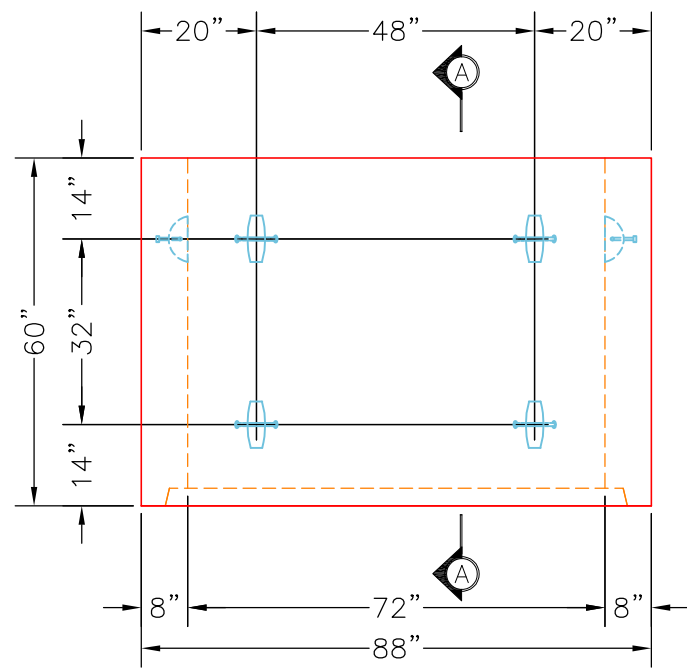

FRONT VIEW

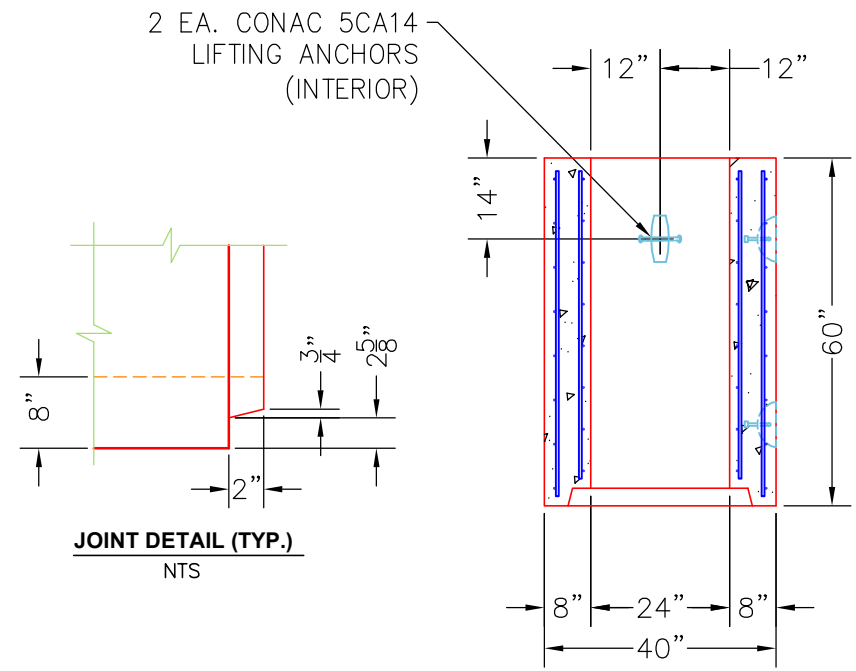

JOINT DETAIL (TYP.)
NTS

SECTION A-A

<p>PRODUCTION WORK ORDER</p>		<p>PRODUCT I.D.: CBC</p>	<p>DESCRIPTION: 2' X 6' X 60" LONG BOX CULVERT (SECTION A)</p>	
	<p>QUALITY CONTROL CHECKLIST</p> <ul style="list-style-type: none"> <input type="checkbox"/> ALL DIMENSIONS CORRECT. <input type="checkbox"/> LIFTERS INSTALLED INSIDE. <input type="checkbox"/> RECESS WITH HAUNCHES CORRECT. <input type="checkbox"/> REINFORCING CORRECT. <input type="checkbox"/> SURFACE QUALITY ACCEPTABLE. <input type="checkbox"/> LIFTERS INSTALLED OUTSIDE. <input type="checkbox"/> PRODUCT SQUARE. 		<p>PRODUCT VIEW: RIGHT SIDE UP</p>	<p>CUSTOMER: DOUBLE A SERVICES, INC.</p>
			<p>PLANT: BEAVER DAM, KY.</p>	<p>PROJECT: DOUBLE A CULVERT</p>
			<p>WEIGHT: 9,022 LBS.</p>	<p>STRUCTURE: 6FT SPAN X 2FT RISE BC</p>
			<p>TOP JOINT: N/A</p>	<p>SALES ORDER/QUOTE NO: 25-3087</p>
			<p>BOTTOM JOINT: GROOVE</p>	<p>PC: A. CHAMBERS DRAWING: J. COPPAGE</p>
		<p>QC CHECK INITIALS:</p>	<p>DATE: 10/6/25 SCALE: NTS PG. 1 of 1</p>	

AAC ENGINEERING, PLLC

Sht _____ of _____

By: Childs

Ck: _____

9/16/2025 10:21:41 PM

p. 1 of 2

Project : prelim 6x2 1 foot

Task : 8" walls, base & 0 haunch

Client: Infrastructure pre

Job No. :

File: Four Sided

Spec.: LRFD 9th ed.
Type of Culvert: Precast

Physical Dimensions

Clear Span: 6'-0"
Clear Height: 2'-0"
Top Slab: 8"
Bottom Slab: 8"
Ext. Wall: 8"
Fill Depth: 1.00 ft
Length: 8'-0"
Skew Angle: 0.00 deg
Bottom Slab Support: Full Slab
Top Haunch, Width: 0"
Top Haunch, Height: 0"
Bottom Haunch, Width: 0"
Bottom Haunch, Height: 0"

Material Properties

Concrete
Strength, fc: 5.000 ksi
Density: 0.150 kcf
Elasticity, Ec: 3834 ksi
Type: Normal wt

Steel
Yield, fy: 65 ksi
Allow Stress: 39 ksi
Elasticity, Es: 29000 ksi

Soil
Density: 0.120 kcf

Exposure Factor
Class 2 Exposure
Reinforcement Covers
Ext. Cover Top Slab: 2"
Ext. Cover Bottom Slab: 1"
Ext. Cover Walls: 1"
Int. Cover Walls: 1"
Int. Cover Top Slab: 1"
Int. Cover Bottom Slab: 1"

Controlling Ratings

Inventory Rating: 1.07
Operating Rating: 1.39

Loads

Live Load
Vehicle Names: HL-93
Traffic Direction: Parallel
Eq. Height of Soil: 4.00 ft (Calc'd)

Dead Load
Future Wearing Surface: 0.000 klf
Additional Dead Load: 0.000 klf
Concentrated Loads: none

Lateral Soil Loads
Eq. Fluid Press. Max: 60.00 pcf
Eq. Fluid Press. Min: 30.00 pcf

Interior Water Pressure: yes, head pressure = 0 ft
Exterior Water Pressure: no

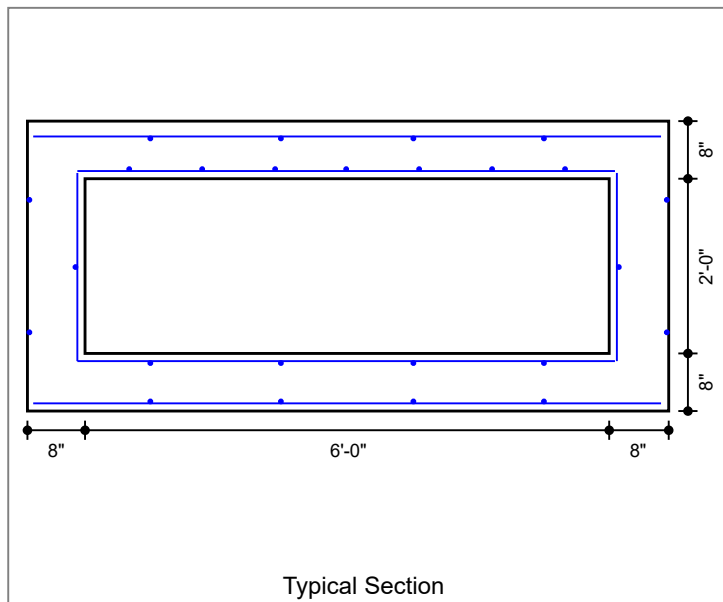
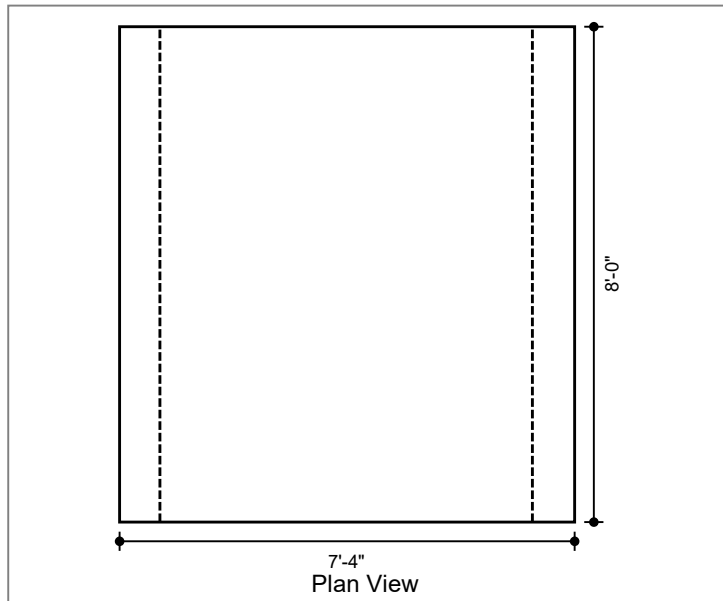

AAC ENGINEERING, PLLC

Sht _____ of _____

By: Childs

Ck: _____

9/16/2025 10:21:41 PM

p. 2 of 2

Project : prelim 6x2 1 foot

Task : 8" walls, base & 0 haunch

Client: Infrastructure pre

Job No. :

File: Four Sided

Concrete Summary

Volume of Concrete: 0.461 cy/ft Total Volume of Concrete: 3.687 cy

Reinforcing Steel Bar Schedule (lb)

Location	Mark	Sheets Included	As Provided
Top Slab(Int)	A100 (AS2)	Top	0.270
Bot Slab(Int)	A200 (AS3)	Bot	0.240
Top Slab(Ext)	A300 (AS7)	L&R	0.198
Bot Slab(Ext)	A400 (AS8)	L&R	0.198
Corner(Top)	A1 (AS1)	L&R	0.198
Corner(Bot)	A2 (AS1)	L&R	0.198
Wall(Int)	B1 (AS4)	Bot	0.240
Longit. Top (Int)	C100 (AS5)	Top	0.192
Longit. Bot (Int)	C200	Bot	0.107
Longit. Top (Ext)	C1 (AS6)	L&R	0.107
Longit. Bot (Ext)	C1 (AS6)	L&R	0.107
Longit. Wall (Ext)	C1 (AS6)	L&R	0.107
Longit. Wall (Int)	C1 (AS6)	T&B	0.107

REINFORCEMENT SUMMARY
 =====

M dimension = 1' 3" (method of equivalent capacity)
 = 2' 10" (method of contraflexure - ASTM)

Reinforcing steel Schedule

Location	Mat Mark	Sheets Included	Layers	As,prv (in2/ft)	As,str (in2/ft)	Truck
Top slab (int)	A100 (AS2)	Top	1	0.270	0.269	AA
Bot Slab (int)	A200 (AS3)	Bot	1	0.240	0.233	AA
Top slab (ext)	A300 (AS7)	L&R	1	0.198	0.192	AA
Bot Slab (ext)	A400 (AS8)	L&R	1	0.198	0.192	AA
Corner Top-U	A1 (AS1)	L&R	1	0.198	0.192	AA
Corner Bottom-U	A2 (AS1)	L&R	1	0.198	0.192	AA
Ext wall (int)	B1 (AS4)	Bot	1	0.240	0.192	AA
Top slab (int- 1)	C100 (AS5)	Top	1	0.192	0.192	AA
Bot Slab (int- 1)	C200	Bot	1	0.107	0.030	AA
Temperature (1)	C1 (AS6)	L&R	1	0.107	0.030	AA
Temperature (1)	C1 (AS6)	L&R	1	0.107	0.030	AA
Temperature (1)	C1 (AS6)	L&R	1	0.107	0.030	AA
Temperature (1)	C1 (AS6)	T&B	1	0.107	0.030	AA

Note: A denotes flexural steel, B denotes vertical steel, C denotes longitudinal steel

AS Bar Marks

Location	Governing Mode	As Gvrn in2/ft
Transverse Side Wall - Outside Face (AS1)	c	0.198
Transverse Top Slab - Inside Face (AS2)	a	0.270
Transverse Bottom Slab - Inside Face (AS3)	a	0.240
Transverse Side Wall - Inside Face (AS4)	c	0.240
Distribution Top Slab - Inside Face (AS5)		0.192
Distribution Top Slab - Outside Face (AS6)		0.107
Transverse Top Slab - Outside Face (AS7)	c	0.198
Transverse Bottom Slab - Outside Face (AS8)	c	0.198

Notes: 1.) Final areas of steel provided must be checked in analysis mode
 2.) As Controlled By: a - Flexure, b - Crack Control, c - Minimum Steel, d - Fatigue

Sheet Inventory

Interior sheets - 2 sheet layout with laps located in the wall

Sheet Loc.	Mat Mark	Zone	Size	Spac. (in)	Length (ft-in)	Area (in2/ft)	H leg (ft-in)	V leg (ft-in)	Cross Wires (L,tot= 7-11)	Mat Mark	Size	Spac. (in)	Area (in2/ft)	wgt (lbs)
Top	A100	Base	w4.5	2.00	9- 2	0.270	6- 2	1- 6	C100	w16	10.00	0.192	103	
	B1	Base	w4	2.00	9- 2	0.240	6- 2	1- 6	C1	w16	18.00	0.107	26	
(1) sheets, Total weight: 129														
Bot	A200	Base	w4	2.00	9- 2	0.240	6- 2	1- 6	C200	w16	18.00	0.107	86	
	B1	Base	w4	2.00	9- 2	0.240	6- 2	1- 6	C1	w16	18.00	0.107	26	
(1) sheets, Total weight: 112														

Exterior sheets - 2 sheet layout with laps located in the slab

Sheet Loc.	Mat Mark	Zone	Size	Spac. (in)	Length (ft-in)	Area (in2/ft)	H leg (ft-in)	V leg (ft-in)	Cross Wires (L,tot= 7-11)	Mat Mark	Size	Spac. (in)	Area (in2/ft)	wgt (lbs)
L&R	A300	Base	w16.5	10.00	11- 1	0.198	4- 0	3- 1	C1	w16	18.00	0.107	63	
	A400	Base	w16.5	10.00	11- 1	0.198	4- 0	3- 1	C1	w16	18.00	0.107	26	
	A1	Base	w16.5	10.00	4- 5	0.198	2- 6	1-11	C1	w16	18.00	0.107	26	
	A2	Base	w16.5	10.00	4- 1	0.198	2- 1	2- 0	C1	w16	18.00	0.107	26	
(2) sheets, Total weight: 282														

Weight of steel: 65 lb/ft Total weight of all sheets: 523

Notes:
 Epoxy coating may be needed for A1, A300, and some C1 reinforcement, check with governing agency.
 L&R - left and right, TC - top corner, BC - bottom corner, INT - interior walls, EXT - exterior walls
 Nested line wires are additive to the base line wires, but nested cross wires replace base cross wires.
 Adder sheets may require cross wires, check with mesh supplier.