

25-3077
 MONTGOMERY CO AIRPORT BUILDING
 PRODUCT ID - CVBS
 FLOOR - BFPG-10
 WEIGHT - 6,075 LBS EACH
 1 REQUIRED

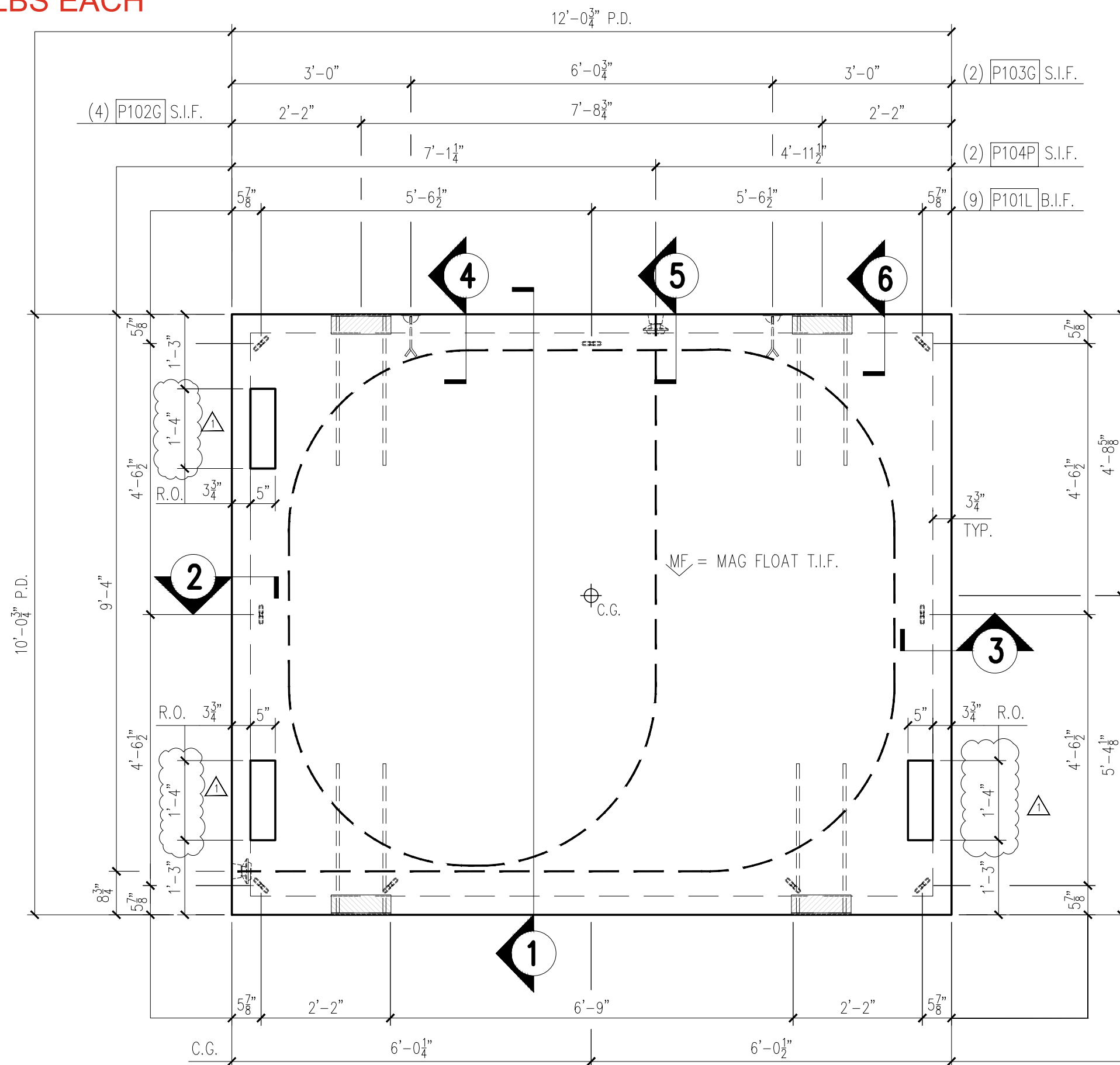

FLOOR FORM VIEW
 SCALE: 1/2" = 1'-0"

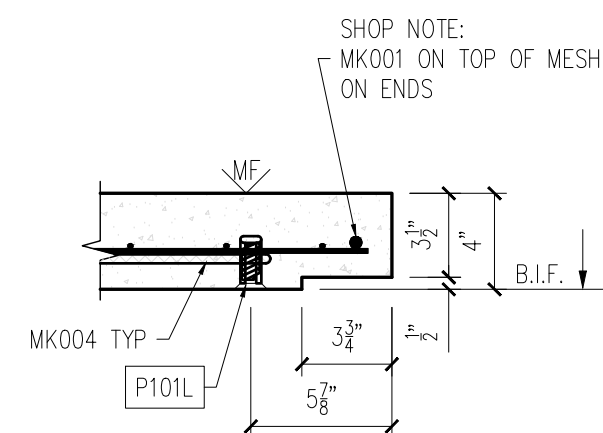
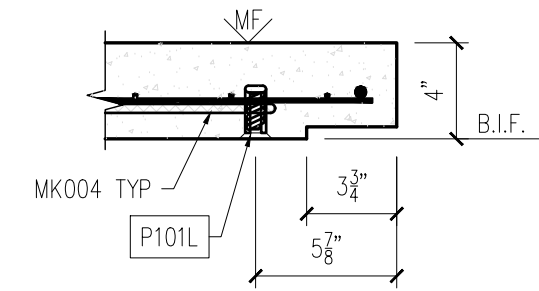
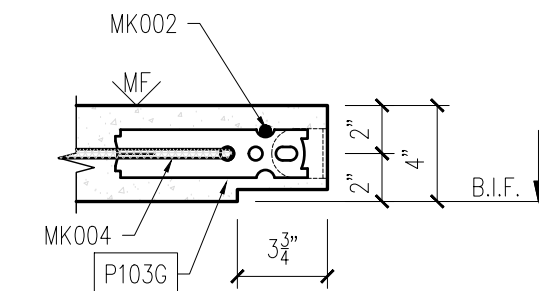
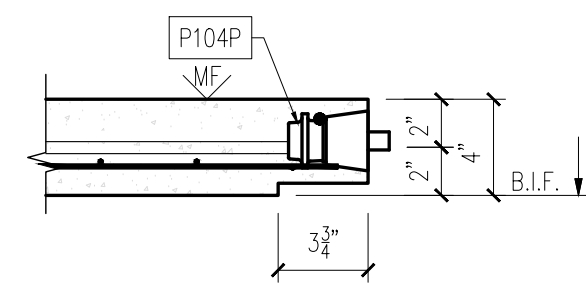
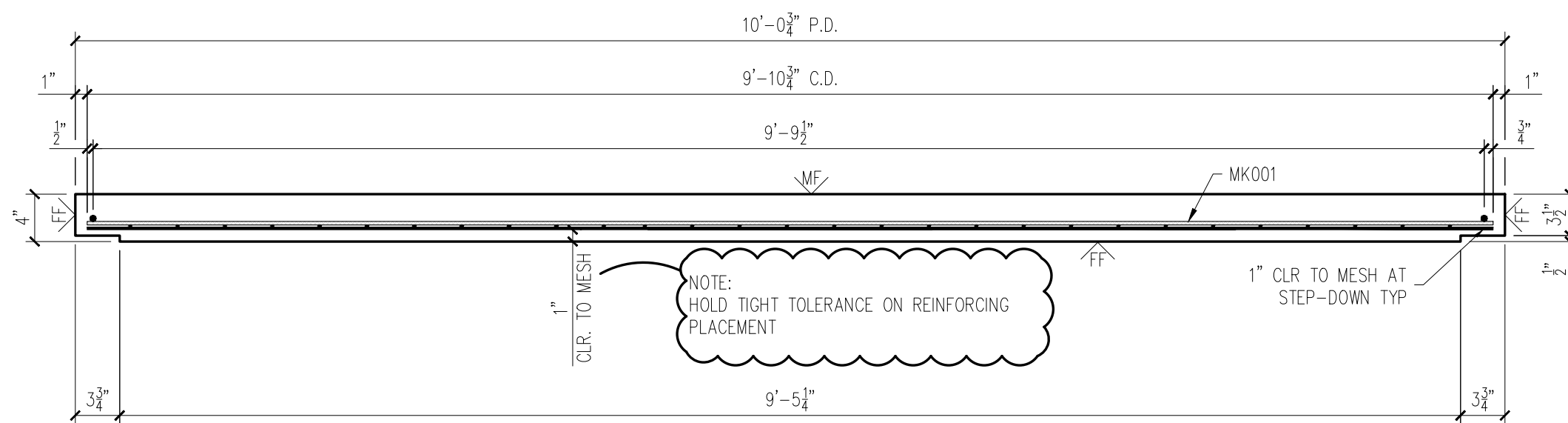

MESSAGE CENTER

- REFER TO DETAILS FOR REINFORCEMENT/CABLE PLACEMENT
- SHOP TICKET SHOWS INSIDE SURFACE OF FLOOR CAST FACE DOWN

CHECKED BY: DATE:
 APPROVED BY: DATE:

BILL OF MATERIALS		
MARK #	DESCRIPTION	QTY
P101L	1/2" X 1 1/4" F-63 FLARED THIN SLAB COIL INSERT (ELECTROPLATED)	9
P102G	ESW P-4 LIFTING ANGLE (GALV.)	4
P103G	2 TON RL-4 TECH ERECTION ANCHOR (79527) (GALV.)	2
P104P	U-5 POST TENSION ANCHOR (PLAIN) WITH PLASTIC POCKET	2

HANDLING INSTRUCTIONS

5

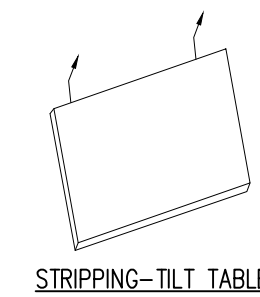

4

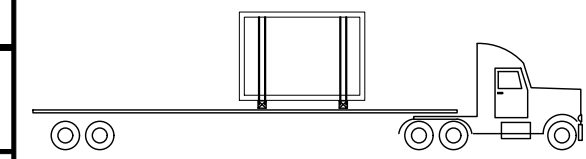

3

YARD STORAGE

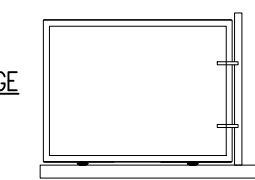

2

ERECTION

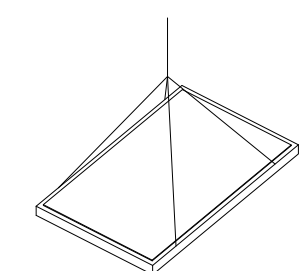

CONCRETE INSTRUCTIONS

CONCRETE RELEASE @ 2,500 P.S.I.	
CONCRETE @ 28 DAYS: 5,000 P.S.I.	
POST-TENSION @ 3,500 P.S.I.	
CONCRETE MIXES	
CONCRETE - GRAY	VOLUME = 1.50 C.Y.
CONCRETE - MIX 1	VOLUME = - C.Y.
CONCRETE - MIX 2	VOLUME = - C.Y.
SOFT SOUND	VOLUME = - C.Y.
TOTALS	VOLUME = 1.50 C.Y.
WEIGHT: 6,075 LBS.	

FINISHING INSTRUCTIONS

MF = MAG FLOAT FINISH
 FF = FORM FINISH

L = 12'-0 3/4"	SQ.FT.(T.I.F.) = 121.4
W = 10'-0 3/4"	SQ.FT.(T.I.F.) = -
D = 4"	SQ.FT.(T.I.F.) = -

CONTROL NUMBERS:

PRODUCT	SALES ORDER NUMBER
BUILDING	STANDARD
SHEET NUMBER	NUMBER REQUIRED
1 OF 2	1

EASI-SET® WORLDWIDE
 5119 Catlett Rd. • Midland, VA 22728 • info@EasiSet.com
 www.EasiSet.com • 800-547-4045 • Fax 540-439-2541

DATE	REV	INI.	WCR	DESCRIPTION	REVISED OPENING DIMENSION
11.05.25					

PROJECT: STANDARD 10' GABLED FLOOR
 10X12 GABLED BUILDING
 CONTRACTOR: INFRASTRUCTURE PRECAST

SCALE	NTS
DRAWN BY	WCR
CHECK BY	JAD
ISSUE DATE	10.15.25
PIECE MARK	BFPG-10

25-3077
 MONTGOMERY CO AIRPORT BUILDING
 PRODUCT ID - CVBS
 FLOOR - BFPG-10
 WEIGHT - 6,075 LBS EACH
 1 REQUIRED

SHOP NOTE:
 DIMENSIONS PROVIDED ARE PULLED FROM EDGE OF
 CAGE TO CENTERLINE OF REBAR AND TO CENTER
 OF REBAR TO CENTER OF REBAR

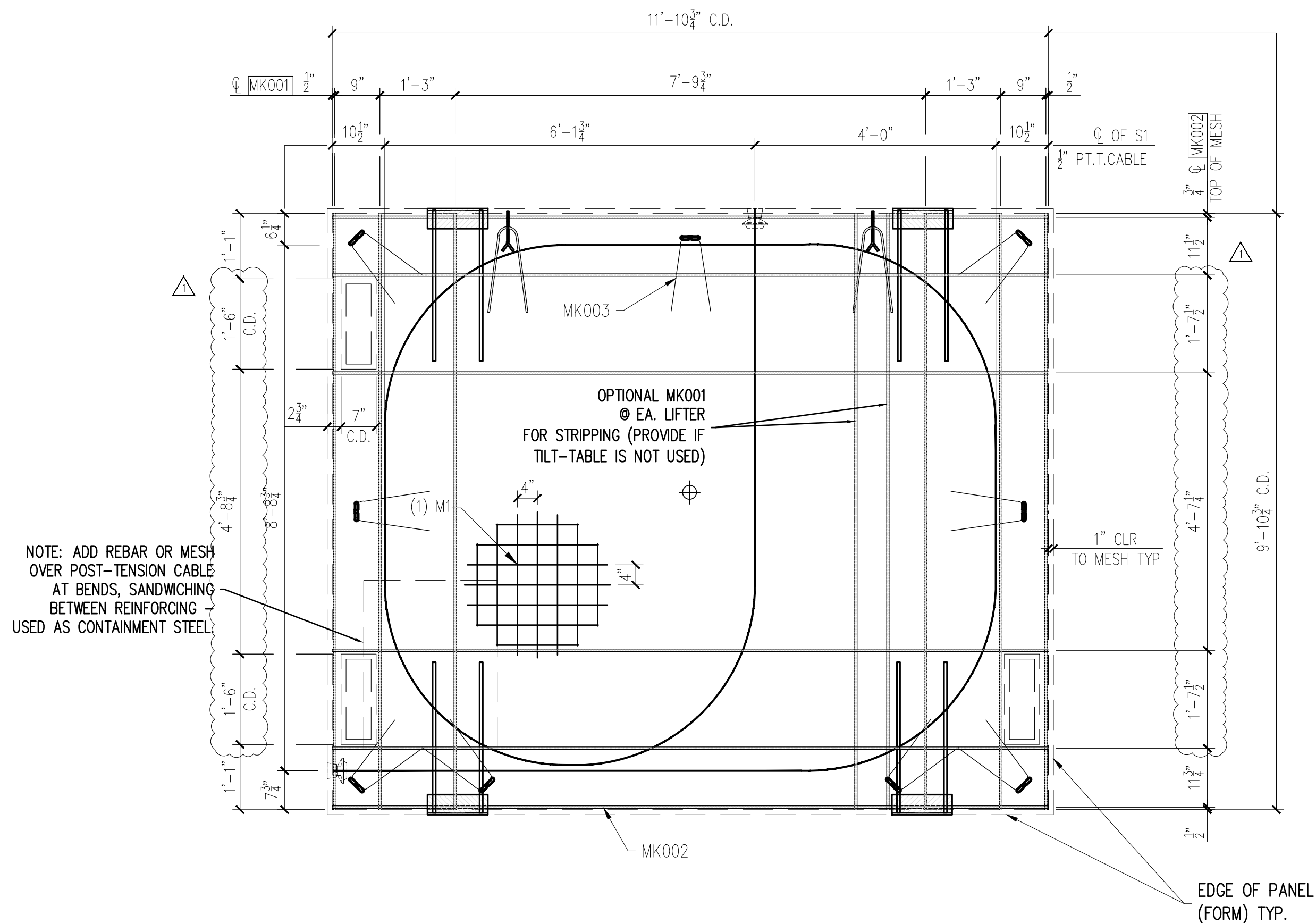

FLOOR REINFORCING VIEW
 SCALE: 1/2" = 1'-0"

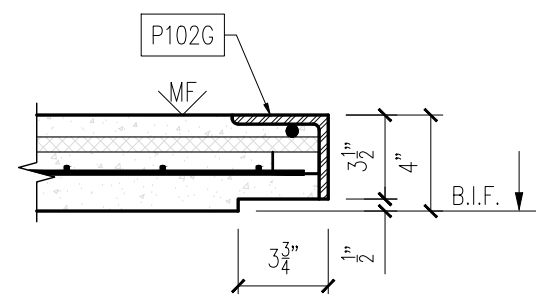

6

MESSAGE CENTER

1. REFER TO DETAILS FOR REINFORCEMENT/CABLE PLACEMENT

2. SUPPLEMENTAL STEEL FOR STRIPPING AND HANDLING MAY BE ADDED AS REQUIRED.

CHECKED BY: DATE:
 APPROVED BY: DATE:

NOTES:

1. TRIM PLASTIC SHEATH AT BOTH ENDS OF THE PT CABLE TO FIT BETWEEN U-5 ANCHOR PLATES

2. CONSTRUCT REBAR-MESH CAGE ACCORDING TO THE DRAWINGS. SECURE LIFTING APPARATUS TO FORM AND ADD PROPER REINFORCEMENT. PLACE REBAR-MESH CAGE AND HAIRPINS AT INSERTS WITH PROPER CLEARANCES (PER DRAWINGS).

3. PLACE AND SECURE PT CABLE AS INDICATED ON THE DRAWINGS (REINFORCING VIEW)

PRODUCT BUILDING SHEET NUMBER
 SALES ORDER NUMBER STANDARD NUMBER REQUIRED

REINFORCING SCHEDULE		
MARK #	DESCRIPTION	QTY
MK001	#3 X 9'-10"	6
MK002	#3 X 11'-10"	6
MK003	#3 X 3'-0"	11
MESH SCHEDULE		
MARK #	DESCRIPTION	QTY
S1	1/2" X 50'-5" LONG P.T. CABLE	1
M1	W4XW4 4"X4" WWF 9'-10 3/4" X 11'-10 3/4"	1

DATE	DESCRIPTION	REV
11.05.25 <td>REVISED OPENING DIMENSION <td>WCR</td> </td>	REVISED OPENING DIMENSION <td>WCR</td>	WCR

PROJECT: STANDARD 10' GABLED FLOOR 10X12 GABLED BUILDING
 CONTRACTOR: INFRASTRUCTURE PRECAST

SCALE NTS
 DRAWN BY WCR
 CHECK BY JAD
 ISSUE DATE 10.15.25
 PIECE MARK BFPG-10

EASI-SET® WORLDWIDE
 5119 Callett Rd. • Midland, VA 22728 • info@EasiSet.com
 www.EasiSet.com • 800-547-4045 • Fax 540-439-2541

25-3077 MONTGOMERY CO AIRPORT BUILDING STRESSING PROCEDURES

STRESSING PROCEDURES For Roofs and Floors – Model G101208S

1. Remove form rails. Verify concrete strength with Schmidt Hammer or cylinder breaks. Concrete shall be a minimum of 3,750 PSI before cable can be stressed.
2. Remove recessed plastic pocket-formers at the post-tensioning anchor.
3. Remove the plastic sheath from the strand all the way from the base of the anchor to the end of the strand. Clean off grease from exposed portion of cable. Use a suitable solvent. Never heat or use flame on the cable.
4. Insure that the tapered holes in the anchors are cleaned and free of any debris or cement paste, which might interfere with proper wedge seating.
5. Install wedge sets around the strand at each anchor. Press the wedges in with the fingers evenly. Then, using a hand wedge setter, engage the wedges securely so that the stress will be evenly distributed over the wires of the strand.
6. Slide the stressing jack over the cable and place against the wedges installed in the cast-in anchors (see details A & B).
7. Using manufacturer recommendations, properly secure the stressing jack to the strand.
9. Standing back from the system, engage the jack to stress the strands until the pump pressure gauge corresponds to 33 K required tension on the 1/2" cable and note the elongation achieved. Whenever stressing, be sure to observe safety precautions and operator positioning in anticipation of unexpected failures.
NOTE: Force in the tendons shall always be measured by gauge readings and verified by elongation. Compare the elongation noted during stressing to the theoretical (calculated) elongation to ensure proper pull (tension) is reached. Refer to industry manuals (PCI) for the proper methods of calculating elongation.
10. Release pump pressure slowly and remove the jacking system and temporary stressing anchor. Your post release tension on the cable will be 28.5 K.
11. Cut off strand tails at 1" from the wedge and pack the holes with permanent grout. Repeat procedure for other end of cable

SAFETY INSTRUCTIONS:

NOTE: Stressing units are calibrated against load cells to determine the gauge pressures for a particular unit which will produce the desired engineering force. Gauge pressure versus actual load calibration should be checked every six months against a load cell. Never use equipment which has not been tested in the last 6 months. The Quality Control Department has the responsibility to insure the stressing unit is calibrated semi-annually. Refer to manufacturer for calibration charts specifically relating to the particular unit (stressing jack).

ROOF AND FLOOR POST-TENSIONING Stressing System Safety Instructions:

This equipment is designed and built to provide safety during equipment operation. It must be operated and maintained by personnel who are trained in and follow safe procedures. Since the forces involved in tendon stressing are in the order of 33 to 46 kips, it is obvious that failure from any cause could be damaging to personnel and property. Accordingly, stressing equipment operators are expected to observe all applicable safety precautions including the following but not limited to:

1. Before activating the pump, visually check all elastomeric tubing for nicks, cracks, or other damage and repair or replace if required.
2. See that all tubing joints are tightly connected.
3. Be sure that pump is supported in a stable manner and positioned to avoid strain on connection lines.
4. Be sure that protective dunnage and appropriate safety barriers are erected to protect the operator and any others in the area.
5. Observe the gauge pressure that will develop the required tensile force as marked on the tag attached to the pump. Locate this reading on gauge face.
6. Be certain that tensioning twin-rams are positively engaged and correctly aligned.
7. Activate pump and observe gauge. If pressure does not build up promptly, check system for leakage and make sure that anchors and wedges on both ends of the POLYSTRAND® tendons are properly engaged. After an initial tension on the strand (5K), stop and check for alignment. Make sure that the strand is at the top of the slot provided in the tension jack cylinder connector plates.
8. Continue pumping until final pressure/force is attained. When stressing long tendons, multiple strokes and resetting the temporary anchor will be required. – CAUTION – pressure will build extremely fast if rams are fully extended. Monitor ram extension and gauge readings continuously.
9. When the correct force has been applied to the tendon, stop the pump motor and release the pressure on the pack by opening the hydraulic valve.
10. Use care in moving and storing equipment to insure that gauge and tubing are not damaged.
11. Observe site rules pertaining to frequency of gauge calibration.

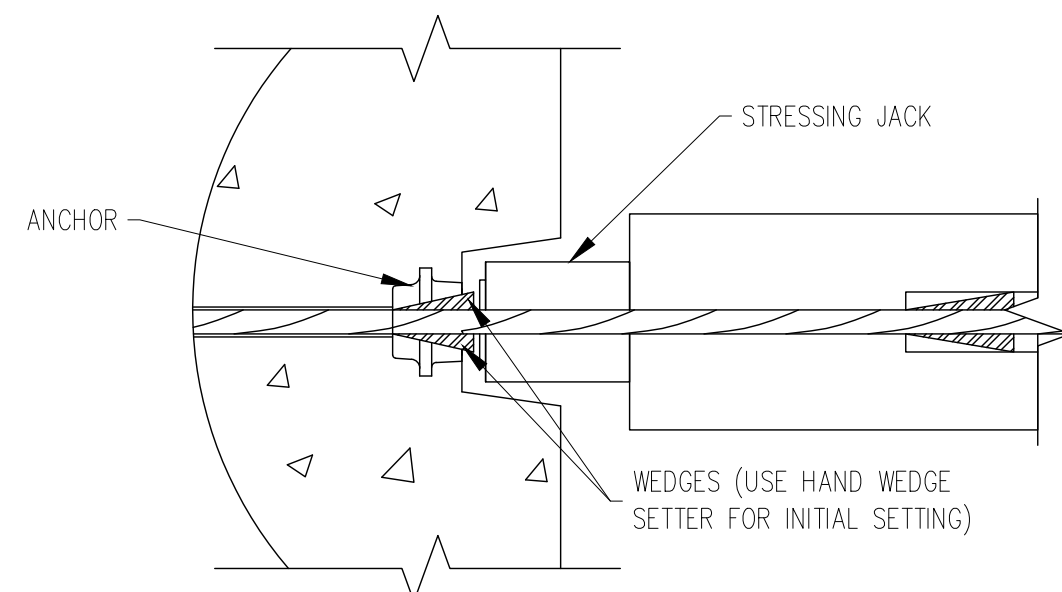

A

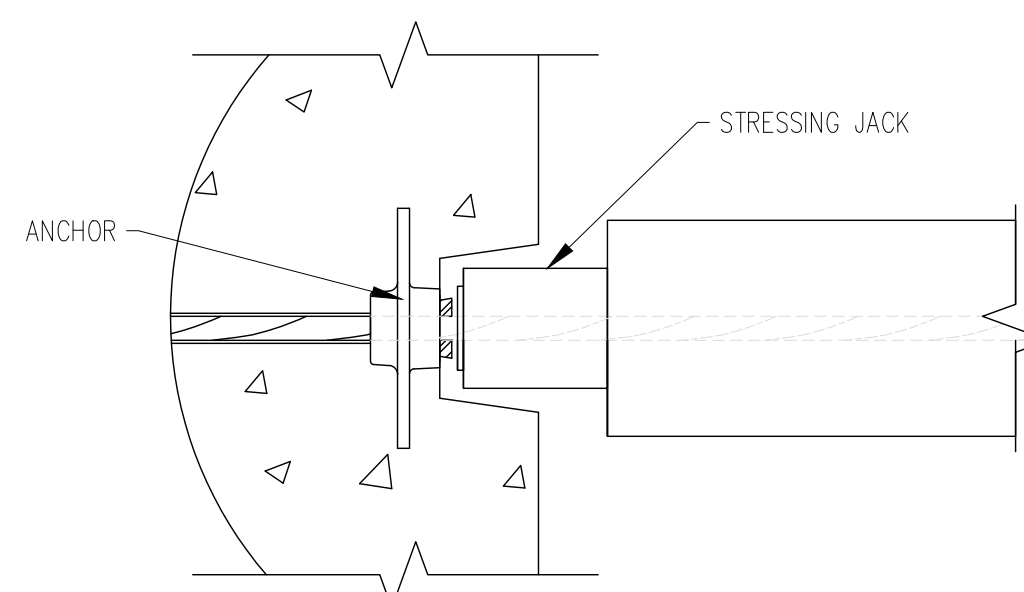

B

DATE	DESCRIPTION	INI.	REV.
			1
			2
			3
			4
			5

PROJECT: 10' X 12' X 7'-6" STANDARD
EASI-SET GABLED BUILDING
CONTRACTOR: INFRASTRUCTURE PRECAST

STRESSING PROCEDURES

SCALE NTS

DRAWN BY JAD

CHECK BY WCR

ISSUE DATE 10.19.25

SHEET P-02

EASI-SET® WORLDWIDE
5119 Callett Rd. • Midland, VA 22728 • info@EasiSet.com
www.EasiSet.com • 800-547-4045 • Fax 540-439-2541

PT Check for Roof Panels/ (PCI MNL - 116)

Material Data

- (7) Wire lo-lax Strand - ASTM A416
- Φps = 0.500 in,
- A = 0.153 in²
- E = 28500000 psi
- fpu = 270 ksi
- Strand Length = 492 in

Assume (Info supplied by strand manufacturer)

- k = 0.0007 Wobble Friction Coeff.
- μ = 0.05 Curvature friction coeff. (Initial tension of 3,000 lbs)

Strand is to be stressed 70% of ultimate
 = 28917 lbs

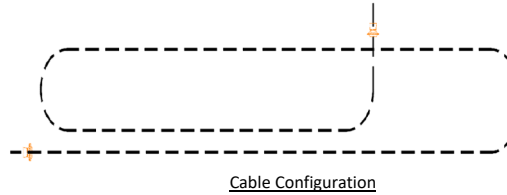

Adjustments to tensioning

- 1) Dead end anchor wedge seating loss
 ~ Expected to be 1/8 in
- 2) Live end anchor wedge seating loss
 ~ Expected to be 1/8 in, recommend over pull 1/8"
- 3) Elastic Shortening
 Neglect for this pnl
- 4) Friction Loss
 Additional force to overcome frictional forces between strand and sheathing

25-3077 MONTGOMERY CO AIRPORT BUILDING STRESSING PROCEDURES

Tensioning Computations

Basic Elongation =
$$\frac{\text{(Force required beyond initial tension)} \text{ (Length of strand between anchorages)}}{\text{(Area of strand)} \text{ (Modulus of Elasticity)}}$$

= 2.92 in

Adjustments

- a) Dead end anchor wedge seating: Add 1/8" to elong. No force adjustment req'd
 Add 1/8 in
 - b) Live end seating: over pull by 1/8"
 1/8 in
- Force adjustment t = 1108 lbs lbs α = curvature = π(2.5) 7.85 radians
- c) Friction losses
$$\frac{PD}{PS} = e^{-(kL + \mu\alpha)}$$
- = 0.656
- Avg. strand force = 0.828 17.19% Loss

Recommend sequential jacking at both ends of the tendon be used to reduce the overstressing the strand at the live end

Friction loss at mid-point of tendon

$$\frac{PD}{PS} = e^{-\frac{(kL + \mu\alpha)}{2}}$$

= 0.810

Avg. strand force over half of tendon = 0.905 9.50% Loss

Total force and elongation at live end must be increased to compensate for friction losses

- Elong. Adjustment = 0.278 in
- Force Adjustment = 2747 lbs
- Total Force Required = 32772 lbs OK

Elongation Summary:

Gross Theoretical Elongation	
Basic Elongation	2.92 in
Dead End Seating Loss	0.125 in
Live End Seating Loss	0.125 in
Friction Losses	0.278 in
Total Elongation	3.45 in
Rounded	3 7/16 in
Tolerance limits -5.0%	3.28 in 3 4/16 in
+5.0%	3.62 in 3 10/16 in