

Job Name: 25-2991 BHS Addition & Renovation Ph 2  
 Job Location: Bardstown, KY  
 Contractor: Parker Excavating, LLC

Plant: 100  
 1/13/2026 4:16:05 PM

Tech: J. Horsley - A  
 PC: Erica Bradley



**Structure ID: 8D**

**P2 MH048CN42**

**ECC CONE w/ 24" HOLE F/G**

- P3) 24" - CASTING HEIGHT - 7"
- P2) 48" - ECC CONE w/ 24" HOLE F/G - 42"
- P1) 48" - MH BASE Custom Ht T/n - 71"
- 1) CASTING - HOE MC-315 F/C Storm
- 1) 48" - Conseal CS-102 1.00"
- 2) Hole - 20
- 1) Hole - 16
- 10) MH Step ML-10-TDS-NCR - 10"

0 lb  
 3200 lb  
 5934 lb  
 258 lb  
 0 lb  
 0 lb  
 0 lb  
 0 lb  
 0 lb  
 Structure Total: 9392 lb

- Structure Notes:
1. PER ASTM C-478 SPECIFICATIONS
  2. CONCRETE: 4,000 PSI AT 28 DAYS
  3. REINFORCEMENT: PER ASTM A615
  4. NO STORM INVERT
  5. STEPS AT 90 DEGREES
  6. HOE MC-315 FRAME & COVER "STORM" SUPPLIED BY ICAST

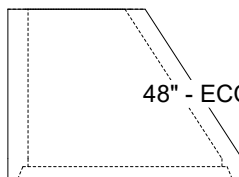
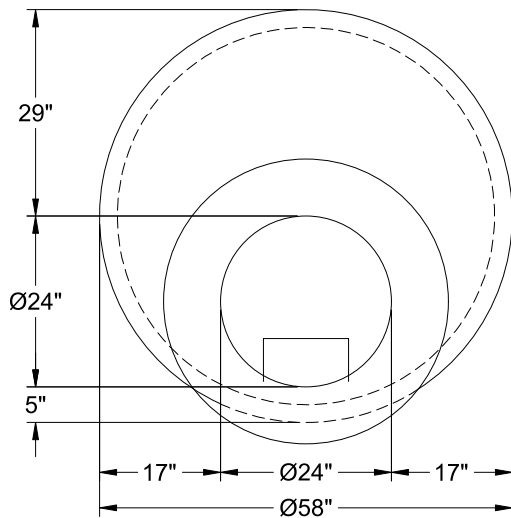

48" - ECC CONE w/ 24" HOLE F/G - 42" - (P2)

Coating (Int):  
 Coating (Ext):

Seam Up: Flat  
 Seam Dn: Groove

Wall Thickness: 5"

Height (Ext): 42"

Weight (Net): 3200 lb  
 Volume (Net): 0.5cu.yd