

Job Name: 25-2991 BHS Addition & Renovation Ph 2
 Job Location: Bardstown, KY
 Contractor: Parker Excavating, LLC

Plant: 100

1/13/2026 3:49:29 PM

Tech: J. Horsley - A

PC: Erica Bradley



Structure ID: 8D

P1 MH048BAVF

MH BASE Custom Ht T/n

- P3) 24" - CASTING HEIGHT - 7"
- P2) 48" - ECC CONE w/ 24" HOLE F/G - 42"
- P1) 48" - MH BASE Custom Ht T/n - 71"
- 1) CASTING - HOE MC-315 F/C Storm
- 1) 48" - Conseal CS-102 1.00"
- 2) Hole - 20
- 1) Hole - 16
- 10) MH Step ML-10-TDS-NCR - 10"

0 lb
 3200 lb
 5934 lb
 258 lb
 0 lb
 0 lb
 0 lb
 0 lb
 0 lb
 Structure Total: 9392 lb

- Structure Notes:**
1. PER ASTM C-478 SPECIFICATIONS
 2. CONCRETE: 4,000 PSI AT 28 DAYS
 3. REINFORCEMENT: PER ASTM A615
 4. NO STORM INVERT
 5. STEPS AT 90 DEGREES
 6. HOE MC-315 FRAME & COVER "STORM" SUPPLIED BY ICAST

Rim: 644.96' Rim to Invert: 9.96' Slack: 0.82" Sump: 1.3" Step Position: 0°

Position	Elev	Angle	Ext. (cw)	Pipe	Pipe OD	Connector	Hole	Horz Size	Up ()	Offset
Invert 1	635'	0°	0"	15" HDPE	17.6"	Hole 20	20"	20.629"	0"	0"
Invert 2	635.06'	270°	136.659"	12" PVC SDR35	12.5"	Hole 16	16"	16.312"	1.77"	0"
Invert 3	638.05'	180°	91.106"	15" VCP	17.75"	Hole 20	20"	20.629"	36.525"	0"
Invert 4										
Invert 5										
Invert 6										
Invert 7										
Invert 8										

RIGHT-SIDE UP VIEW (int. dimensions)

UPSIDE-DOWN VIEW (int. dimensions)

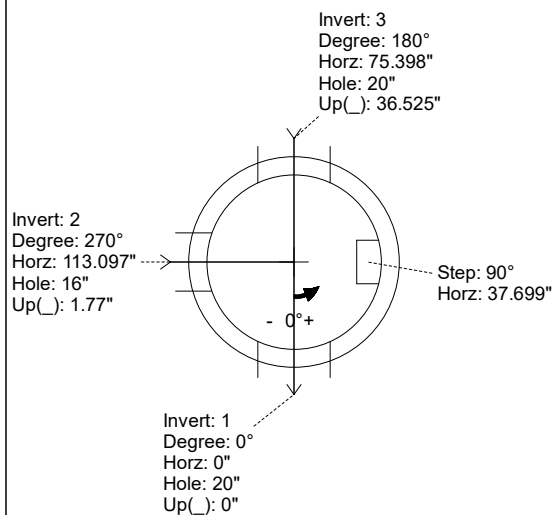
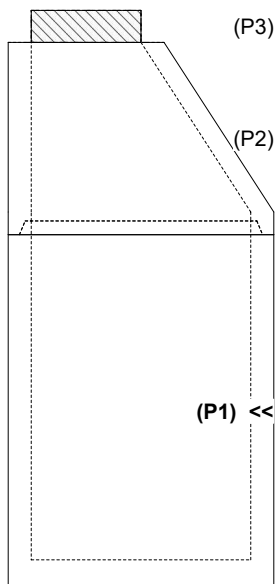

INSIDE WALL DIMENSIONS

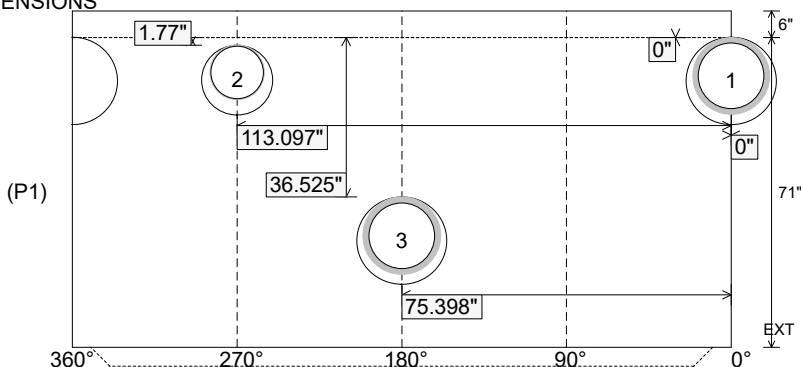

Coating (Int):
 Coating (Ext):

Seam Up: Tongue
 Seam Dn: n/a

Wall Thickness: 5"
 Floor Height: 6"

Height (Int): 71"
 Height (Ext): 77"

Weight (Net): 5934 lb
 Volume (Net): 1.52cu.yd