

**Job Name: 25-2991 BHS Addition & Renovation Ph 2**  
**Job Location: Bardstown, KY**  
**Contractor: Parker Excavating, LLC**

PC: Erica Bradley  
 TECH: J. Horsley - A  
 Plant: 100



Structure ID: 7B  
 Spec: Storm  
 Type: STM.MH  
 Size: 48"

Rim: 645.6'  
 Invert: 638.39'  
 Rim to Invert: 7.21'

Sump: 1.9"  
 Floor (Top): 638.232'  
 Floor Height: 6"

Floor (Bot): 637.732'  
 Overall Height: 7.833'  
 Slack: 0.42"

**Structure Notes:**  
 PLAN LABEL: MH-7B  
 1. PER ASTM C-478 SPECIFICATIONS  
 2. CONCRETE: 4,000 PSI AT 28 DAYS  
 3. REINFORCEMENT: PER ASTM A615  
 4. NO STORM INVERT  
 5. STEPS AT 270 DEGREES  
 6. HOE MC-315 FRAME & COVER "STORM" SUPPLIED BY ICAST

**STRUCTURE SUMMARY:**

P4) 24" - CASTING HEIGHT - 7"	0 lb
P3) 24" - GRADE RING F/F - 3"	202 lb
P2) 48" - ECC CONE w/ 24" HOLE F/G - 30"	2050 lb
P1) 48" - MH BASE T/n - 48"	4051 lb
1) CASTING - HOE MC-315 F/C Storm	258 lb
1) 48" - Conseal CS-102 1.00"	0 lb
2) Hole - 30	0 lb
7) MH Step ML-10-TDS-NCR - 10"	0 lb
<b>Structure Total:</b>	<b>6562 lb</b>

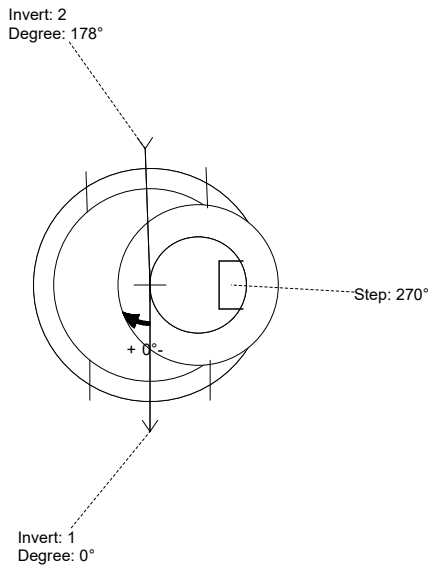

Position	Elev	Angle	Pipe	Pipe OD	Hole	Connector	Up (")	Ref
Rim	645.6'							
Reducer								
Invert 1	638.39'	0°	24" HDPE	27.8"	30"	Hole 30	0"	P1
Invert 2	638.49'	178°	24" HDPE	27.8"	30"	Hole 30	1.2"	P1
Invert 3								
Invert 4								
Invert 5								
Invert 6								
Invert 7								
Invert 8								

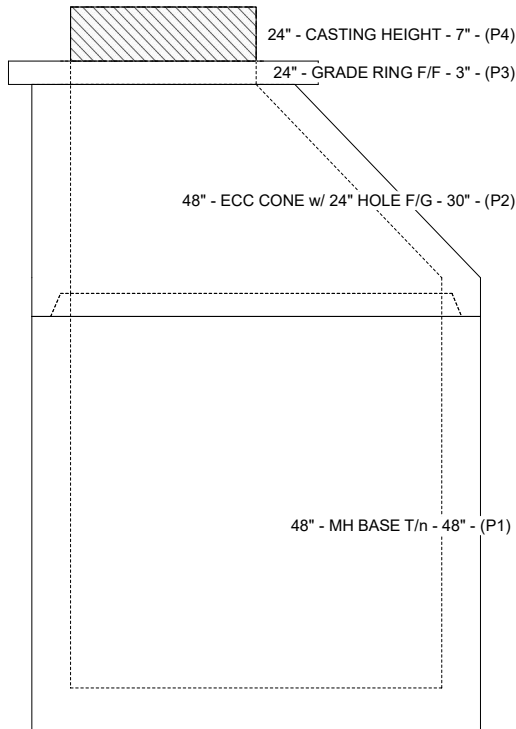

**Cast (Int. Dim.) - Interior Dimensions**

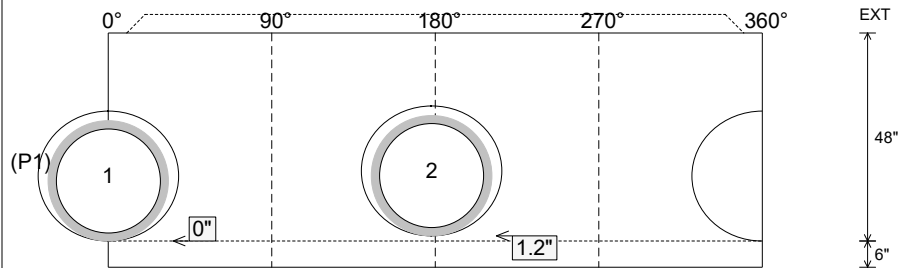

Submittal Drawing  
 1/14/2026 9:21:13 AM

SUBMITTAL  
 APPROVED BY: