

Job Name: 25-2943 Shelby Green Ph.2 Sec.3  
 Job Location: Junction City, KY  
 Contractor: H&S,LLC

Plant: 100  
 12/11/2025 1:20:59 PM

Tech: J. Horsley - A  
 PC: Celina Goff



**Structure ID: SSMH-C1**

**P2 MH048CN24**

**ECC CONE w/ 24" HOLE F/G**

- P4) 24" - CASTING HEIGHT - 8"
- P3) 24" - GRADE RING F/F - 4"
- P2) 48" - ECC CONE w/ 24" HOLE F/G - 24"
- P1) 48" - MH BASE T/n - 30"
- 1) JOINT WRAP - 0.065"x6"x50' CONSEAL CS212
- 1) JOINT WRAP PRIMER - CONSEAL CS-75 (1 gal.)
- 1) 48" - MH INVERT CHANNEL - FULL HEIGHT
- 1) CASTING - HOE KY-510 F/C (KY TY:2)
- 1) 48" - Conseal CS-102 1.00" (Double)
- 2) PSX - 12-08 NYLO
- 4) MH Step ML-10-TDS-NCR - 10"

0 lb  
 270 lb  
 1550 lb  
 3330 lb  
 0 lb  
 0 lb  
 1440 lb  
 510 lb  
 0 lb  
 16 lb  
 0 lb  
 -----  
 7116 lb

- Structure Notes:
1. PER ASTM C-478 SPECIFICATIONS
  2. CONCRETE: 4,000 PSI AT 28 DAYS
  3. REINFORCEMENT: PER ASTM A615
  4. INVERT CHANNEL REQUIRED
  5. STEPS AT 0 DEGREES
  6. HOE KY-510 FRAME & COVER SUPPLIED BY ICAST

Structure Total: 7116 lb

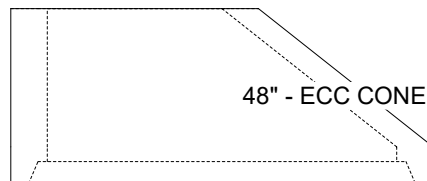
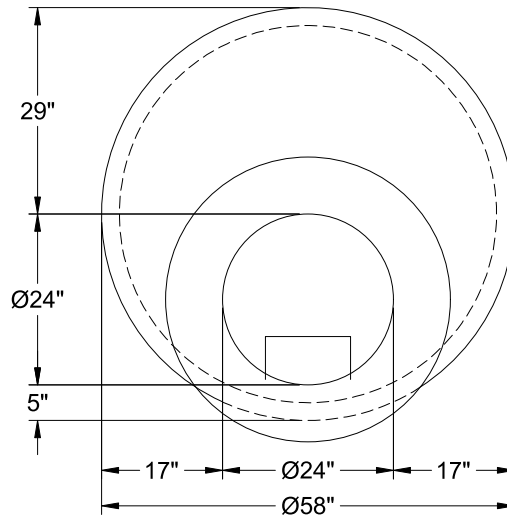

48" - ECC CONE w/ 24" HOLE F/G - 24" - (P2)

Coating (Int):  
 Coating (Ext):

Seam Up: Flat  
 Seam Dn: Groove

Wall Thickness: 5"

Height (Ext): 24"

Weight (Net): 1550 lb  
 Volume (Net): 0.33cu.yd