

Job Name: 25-2943 Shelby Green Ph.2 Sec.3
 Job Location: Junction City, KY
 Contractor: H&S,LLC

Plant: 100

12/11/2025 1:20:17 PM

Tech: J. Horsley - A

PC: Celina Goff



Structure ID: SSMH-C1

P1 MH048BA30

MH BASE T/n

P4) 24" - CASTING HEIGHT - 8"	0 lb
P3) 24" - GRADE RING F/F - 4"	270 lb
P2) 48" - ECC CONE w/ 24" HOLE F/G - 24"	1550 lb
P1) 48" - MH BASE T/n - 30"	3330 lb
1) JOINT WRAP - 0.065"x6"x50' CONSEAL CS212	0 lb
1) JOINT WRAP PRIMER - CONSEAL CS-75 (1 gal.)	0 lb
1) 48" - MH INVERT CHANNEL - FULL HEIGHT	1440 lb
1) CASTING - HOE KY-510 F/C (KY TY.2)	510 lb
1) 48" - Conseal CS-102 1.00" (Double)	0 lb
2) PSX - 12-08 NYLO	16 lb
4) MH Step ML-10-TDS-NCR - 10"	0 lb
Structure Total:	7116 lb

Structure Notes:
 1. PER ASTM C-478 SPECIFICATIONS
 2. CONCRETE: 4,000 PSI AT 28 DAYS
 3. REINFORCEMENT: PER ASTM A615
 4. INVERT CHANNEL REQUIRED
 5. STEPS AT 0 DEGREES
 6. HOE KY-510 FRAME & COVER SUPPLIED BY ICAST
 7. DOUBLE EXTERNAL BANDS FOR BOOTS
 REQUIRED - SUPPLIED BY ICAST

Rim: 1002.08' Rim to Invert: 5.41' Slack: 0.92' Sump: 2' Step Position: 0°

Position	Elev	Angle	Ext. (cw)	Pipe	Pipe OD	Connector	Hole	Horz Size	Up ()	Offset
Invert 1	996.67'	0°	0"	8" PVC SDR35	8.5"	PSX 12-08 NYLO	12"	12.129"	0"	0"
Invert 2	996.77'	170°	86.045"	8" PVC SDR35	8.5"	PSX 12-08 NYLO	12"	12.129"	1.2"	0"
Invert 3										
Invert 4										
Invert 5										
Invert 6										
Invert 7										
Invert 8										

RIGHT-SIDE UP VIEW (int. dimensions)

UPSIDE-DOWN VIEW (int. dimensions)

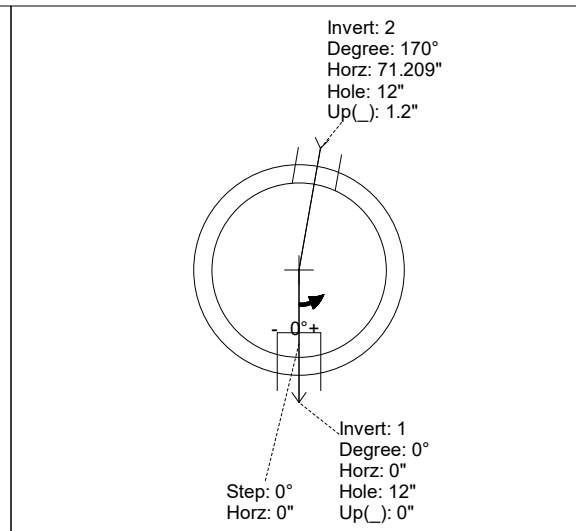
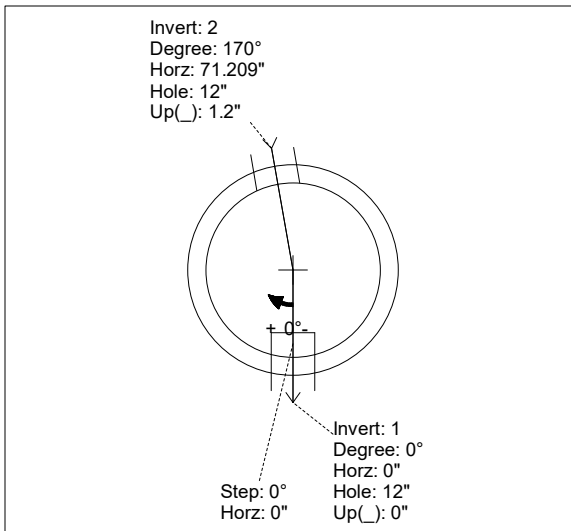
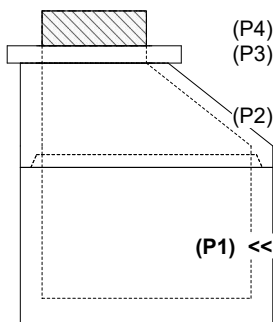

INSIDE WALL DIMENSIONS

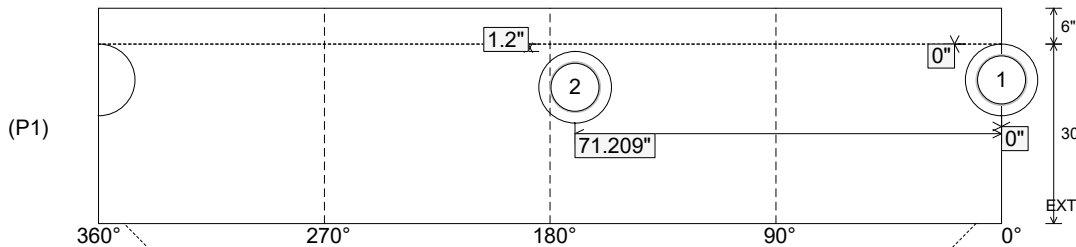

Coating (Int):
 Coating (Ext):

Seam Up: Tongue
 Seam Dn: n/a

Wall Thickness: 5"
 Floor Height: 6"

Height (Int): 30"
 Height (Ext): 36"

Weight (Net): 3330 lb
 Volume (Net): 0.85cu.yd

Structure ID: SSMH-C1

P1 MH048BA30

MH BASE T/n

P4) 24" - CASTING HEIGHT - 8" P3) 24" - GRADE RING F/F - 4" P2) 48" - ECC CONE w/ 24" HOLE F/G - 24" P1) 48" - MH BASE T/n - 30" 1) JOINT WRAP - 0.065"x6"x50' CONSEAL CS212 1) JOINT WRAP PRIMER - CONSEAL CS-75 (1 gal.) 1) 48" - MH INVERT CHANNEL - FULL HEIGHT 1) CASTING - HOE KY-510 F/C (KY TY.2) 1) 48" - Conseal CS-102 1.00" (Double) 2) PSX - 12-08 NYLO 4) MH Step ML-10-TDS-NCR - 10"	0 lb 270 lb 1550 lb 3330 lb 0 lb 0 lb 1440 lb 510 lb 0 lb 16 lb 0 lb ----- Structure Total: 7116 lb
---	---

Structure Notes:

1. PER ASTM C-478 SPECIFICATIONS
2. CONCRETE: 4,000 PSI AT 28 DAYS
3. REINFORCEMENT: PER ASTM A615
4. INVERT CHANNEL REQUIRED
5. STEPS AT 0 DEGREES
6. HOE KY-510 FRAME & COVER SUPPLIED BY ICAST
7. DOUBLE EXTERNAL BANDS FOR BOOTS REQUIRED - SUPPLIED BY ICAST

Rim: 1002.08' Rim to Invert: 5.41' Slack: 0.92" Sump: 2" Step Position: 0°

Position	Elev	Angle	Ext. (cw)	Pipe	Pipe OD	Connector	Hole	Horz Size	Up ()	Offset
Invert 1	996.67'	0°	0"	8" PVC SDR35	8.5"	PSX 12-08 NYLO	12"	12.129"	0"	0"
Invert 2	996.77'	170°	86.045"	8" PVC SDR35	8.5"	PSX 12-08 NYLO	12"	12.129"	1.2"	0"
Invert 3										
Invert 4										
Invert 5										
Invert 6										
Invert 7										
Invert 8										

RIGHT-SIDE UP VIEW (int. dimensions)

UPSIDE-DOWN VIEW (int. dimensions)

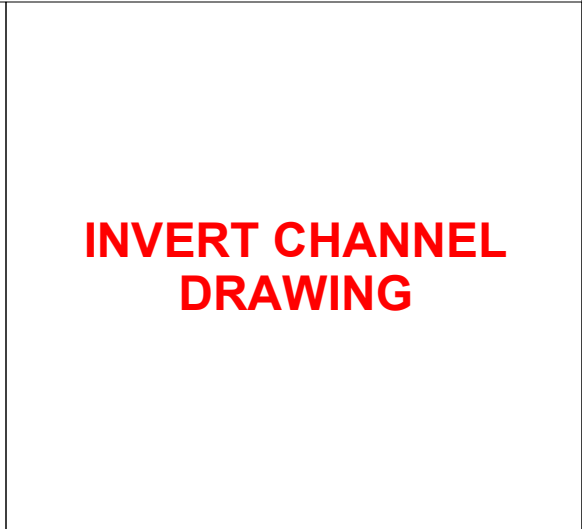
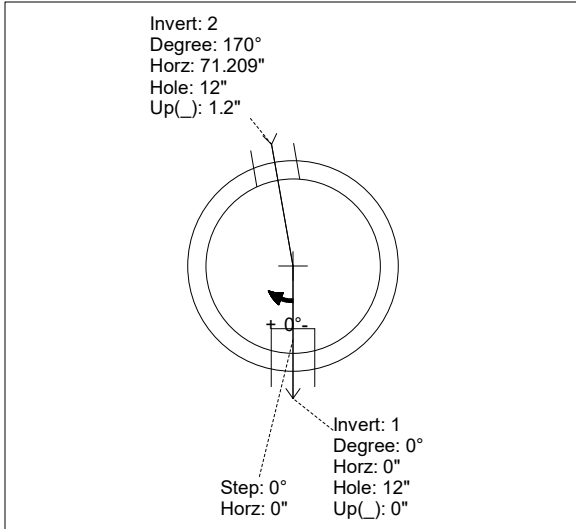
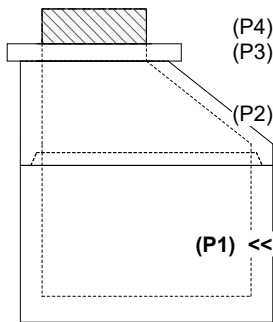

INSIDE WALL DIMENSIONS

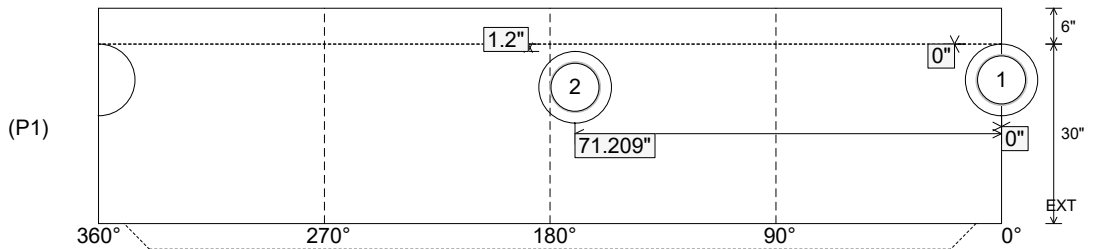

Coating (Int): Coating (Ext):	Seam Up: Tongue Seam Dn: n/a	Wall Thickness: 5" Floor Height: 6"	Height (Int): 30" Height (Ext): 36"	Weight (Net): 3330 lb Volume (Net): 0.85cu.yd
----------------------------------	---------------------------------	--	--	--