

Job Name: 25-2943 Shelby Green Ph.2 Sec.3
 Job Location: Junction City, KY
 Contractor: H&S,LLC

Plant: 100

12/11/2025 1:20:57 PM

Tech: J. Horsley - A

PC: Celina Goff



Structure ID: SSMH-B1

P3 GR3

GRADE RING F/F

- P4) 24" - CASTING HEIGHT - 8"
- P3) 24" - GRADE RING F/F - 3"
- P2) 48" - ECC CONE w/ 24" HOLE F/G - 36"
- P1) 48" - MH BASE T/n - 24"
- 1) JOINT WRAP - 0.065"x6"x50' CONSEAL CS212
- 1) JOINT WRAP PRIMER - CONSEAL CS-75 (1 gal.)
- 1) 48" - MH INVERT CHANNEL - FULL HEIGHT
- 1) CASTING - HOE KY-510 F/C (KY TY:2)
- 1) 48" - Conseal CS-102 1.00" (Double)
- 2) PSX - 12-08 NYLO
- 4) MH Step ML-10-TDS-NCR - 10"

- 0 lb
- 202 lb
- 3000 lb
- 2911 lb
- 0 lb
- 0 lb
- 1440 lb
- 510 lb
- 0 lb
- 16 lb
- 0 lb
-

Structure Total: 8080 lb

Structure Notes:

1. PER ASTM C-478 SPECIFICATIONS
2. CONCRETE: 4,000 PSI AT 28 DAYS
3. REINFORCEMENT: (1) #3 HOOP CENTERED (GRADE 60)

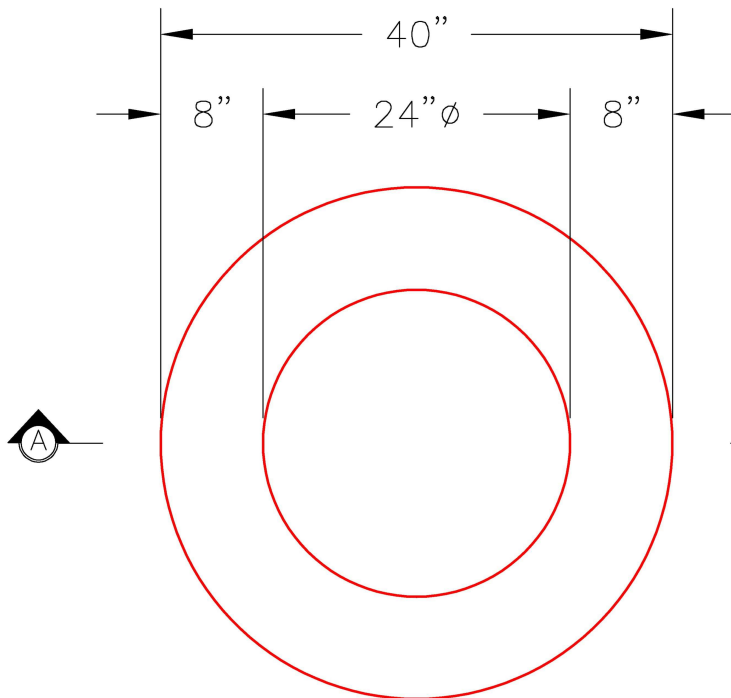

PLAN VIEW

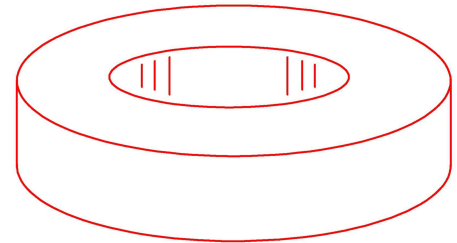

ISOMETRIC VIEW

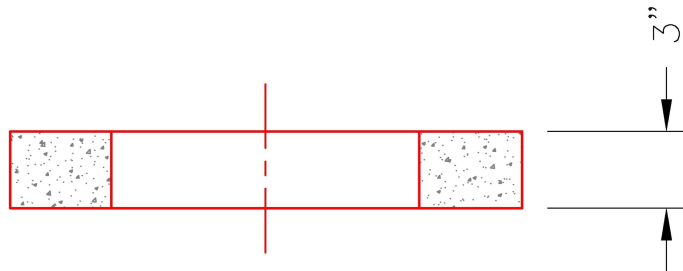

SECTION A-A

Coating (Int):
 Coating (Ext):

Seam Up: Flat
 Seam Dn: Flat

Wall Thickness: 8"

Height (Ext): 3"

Weight (Net): 202 lb
 Volume (Net): 0.05cu.yd