

Job Name: 25-2943 Shelby Green Ph.2 Sec.3  
 Job Location: Junction City, KY  
 Contractor: H&S,LLC

Plant: 100

Tech: J. Horsley - A

12/11/2025 1:20:18 PM

PC: Celina Goff



**Structure ID: SSMH-A7**

**P1 MH048BA24**

**MH BASE T/n**

P4) 24" - CASTING HEIGHT - 8"	0 lb
P3) 24" - GRADE RING F/F - 4"	270 lb
P2) 48" - ECC CONE w/ 24" HOLE F/G - 24"	1550 lb
P1) 48" - MH BASE T/n - 24"	2835 lb
1) JOINT WRAP - 0.065"x6"x50' CONSEAL CS212	0 lb
1) JOINT WRAP PRIMER - CONSEAL CS-75 (1 gal.)	0 lb
1) 48" - MH INVERT CHANNEL - FULL HEIGHT	1440 lb
1) CASTING - HOE KY-510 F/C (KY TY.2)	510 lb
1) 48" - Conseal CS-102 1.00" (Double)	0 lb
2) PSX - 16Y NYLO	16 lb
3) MH Step ML-10-TDS-NCR - 10"	0 lb
<b>Structure Total:</b>	<b>6621 lb</b>

**Structure Notes:**  
 1. PER ASTM C-478 SPECIFICATIONS  
 2. CONCRETE: 4,000 PSI AT 28 DAYS  
 3. REINFORCEMENT: PER ASTM A615  
 4. INVERT CHANNEL REQUIRED  
 5. STEPS AT 0 DEGREES  
 6. HOE KY-510 FRAME & COVER SUPPLIED BY ICAST  
 7. DOUBLE EXTERNAL BANDS FOR BOOTS  
 REQUIRED - SUPPLIED BY ICAST

Rim: 1000.4' Rim to Invert: 4.8' Slack: 0.6" Sump: 3" Step Position: 0°

Position	Elev	Angle	Ext. (cw)	Pipe	Pipe OD	Connector	Hole	Horz Size	Up ( )	Offset
Invert 1	995.6'	0°	0"	10" PVC SDR35	10.5"	PSX 16Y NYLO	16"	16.312"	0"	0"
Invert 2	995.7'	180°	91.106"	10" PVC SDR35	10.5"	PSX 16Y NYLO	16"	16.312"	1.2"	0"
Invert 3										
Invert 4										
Invert 5										
Invert 6										
Invert 7										
Invert 8										

RIGHT-SIDE UP VIEW (int. dimensions)

UPSIDE-DOWN VIEW (int. dimensions)

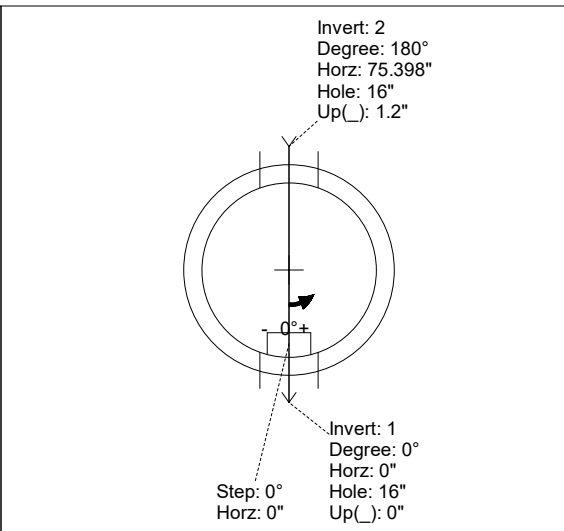
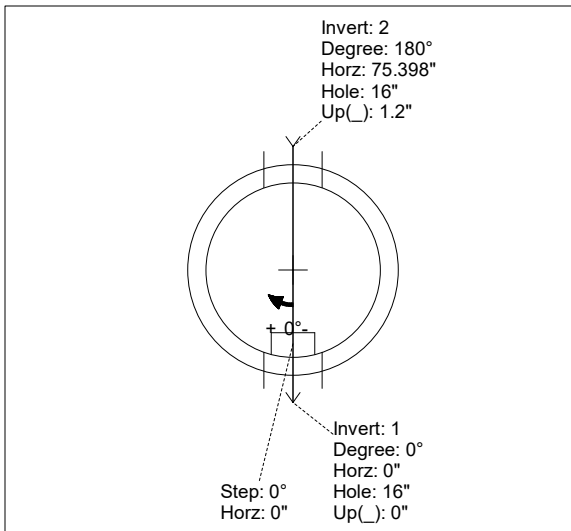
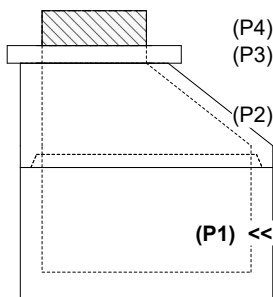

INSIDE WALL DIMENSIONS

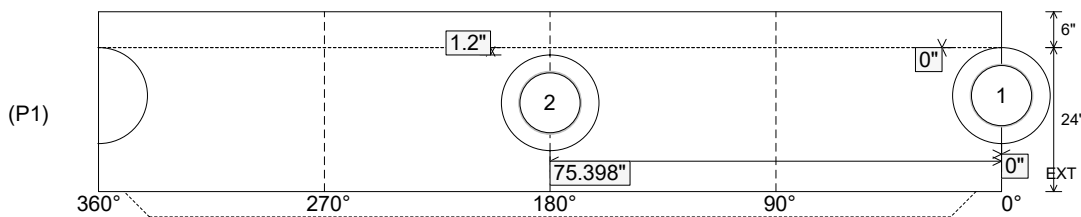

Coating (Int):  
 Coating (Ext):

Seam Up: Tongue  
 Seam Dn: n/a

Wall Thickness: 5"  
 Floor Height: 6"

Height (Int): 24"  
 Height (Ext): 30"

Weight (Net): 2835 lb  
 Volume (Net): 0.72cu.yd

Job Name: 25-2943 Shelby Green Ph.2 Sec.3  
 Job Location: Junction City, KY  
 Contractor: H&S,LLC

Plant: 100

Tech: J. Horsley - A

12/11/2025 1:20:18 PM

PC: Celina Goff



**Structure ID: SSMH-A7**

**P1 MH048BA24**

**MH BASE T/n**

P4) 24" - CASTING HEIGHT - 8"	0 lb
P3) 24" - GRADE RING F/F - 4"	270 lb
P2) 48" - ECC CONE w/ 24" HOLE F/G - 24"	1550 lb
P1) 48" - MH BASE T/n - 24"	2835 lb
1) JOINT WRAP - 0.065"x6"x50' CONSEAL CS212	0 lb
1) JOINT WRAP PRIMER - CONSEAL CS-75 (1 gal.)	0 lb
1) 48" - MH INVERT CHANNEL - FULL HEIGHT	1440 lb
1) CASTING - HOE KY-510 F/C (KY TY.2)	510 lb
1) 48" - Conseal CS-102 1.00" (Double)	0 lb
2) PSX - 16Y NYLO	16 lb
3) MH Step ML-10-TDS-NCR - 10"	0 lb
<b>Structure Total:</b>	<b>6621 lb</b>

**Structure Notes:**  
 1. PER ASTM C-478 SPECIFICATIONS  
 2. CONCRETE: 4,000 PSI AT 28 DAYS  
 3. REINFORCEMENT: PER ASTM A615  
 4. INVERT CHANNEL REQUIRED  
 5. STEPS AT 0 DEGREES  
 6. HOE KY-510 FRAME & COVER SUPPLIED BY ICAST  
 7. DOUBLE EXTERNAL BANDS FOR BOOTS  
 REQUIRED - SUPPLIED BY ICAST

Rim: 1000.4' Rim to Invert: 4.8' Slack: 0.6" Sump: 3" Step Position: 0°

Position	Elev	Angle	Ext. (cw)	Pipe	Pipe OD	Connector	Hole	Horz Size	Up ( )	Offset
Invert 1	995.6'	0°	0"	10" PVC SDR35	10.5"	PSX 16Y NYLO	16"	16.312"	0"	0"
Invert 2	995.7'	180°	91.106"	10" PVC SDR35	10.5"	PSX 16Y NYLO	16"	16.312"	1.2"	0"
Invert 3										
Invert 4										
Invert 5										
Invert 6										
Invert 7										
Invert 8										

RIGHT-SIDE UP VIEW (int. dimensions)

UPSIDE-DOWN VIEW (int. dimenions)

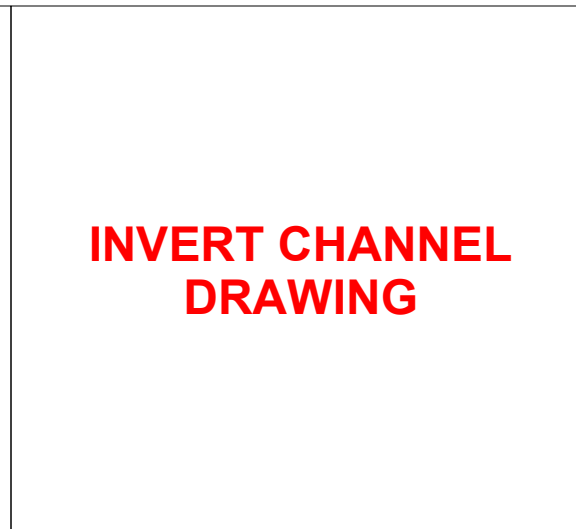
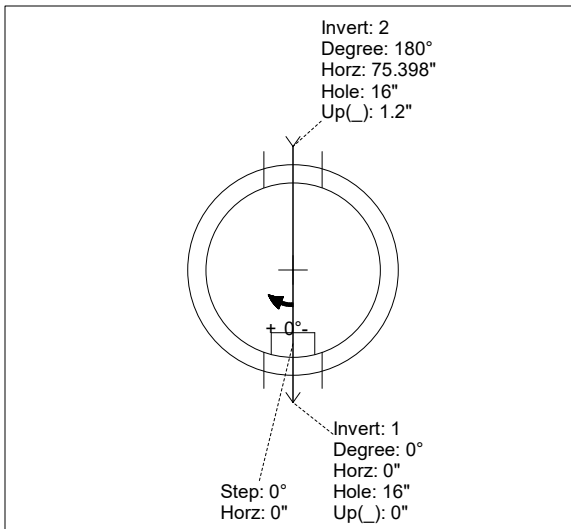
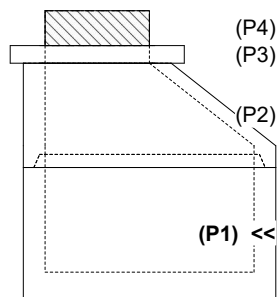

INSIDE WALL DIMENSIONS

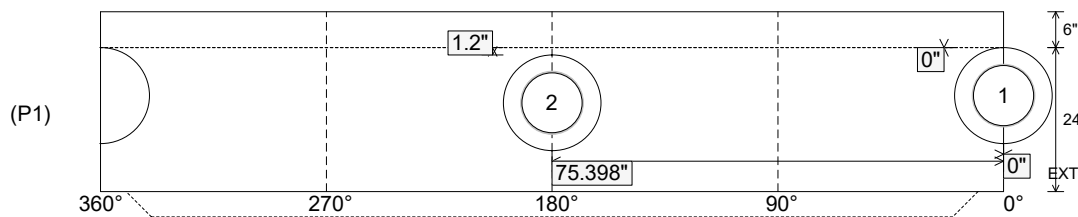

Coating (Int):  
 Coating (Ext):

Seam Up: Tongue  
 Seam Dn: n/a

Wall Thickness: 5"  
 Floor Height: 6"

Height (Int): 24"  
 Height (Ext): 30"

Weight (Net): 2835 lb  
 Volume (Net): 0.72cu.yd