

Job Name: 25-2943 Shelby Green Ph.2 Sec.3
 Job Location: Junction City, KY
 Contractor: H&S,LLC

Plant: 100
 12/11/2025 1:20:56 PM

Tech: J. Horsley - A
 PC: Celina Goff



Structure ID: SSMH-A4

P2 MH048CN36

ECC CONE w/ 24" HOLE F/G

- P3) 24" - CASTING HEIGHT - 8"
- P2) 48" - ECC CONE w/ 24" HOLE F/G - 36"
- P1) 48" - MH BASE T/n - 30"
- 1) JOINT WRAP - 0.065"x6"x50' CONSEAL CS212
- 1) JOINT WRAP PRIMER - CONSEAL CS-75 (1 gal.)
- 1) 48" - MH INVERT CHANNEL - FULL HEIGHT
- 1) CASTING - HOE KY-510 F/C (KY TY.2)
- 1) 48" - Conseal CS-102 1.00" (Double)
- 2) PSX - 16Y NYLO
- 1) PSX - 12-08 NYLO
- 4) MH Step ML-10-TDS-NCR - 10"

0 lb
 3000 lb
 3207 lb
 0 lb
 0 lb
 1440 lb
 510 lb
 0 lb
 16 lb
 8 lb
 0 lb

- Structure Notes:
1. PER ASTM C-478 SPECIFICATIONS
 2. CONCRETE: 4,000 PSI AT 28 DAYS
 3. REINFORCEMENT: PER ASTM A615
 4. INVERT CHANNEL REQUIRED
 5. STEPS AT 0 DEGREES
 6. HOE KY-510 FRAME & COVER SUPPLIED BY ICAST

Structure Total: 8181 lb

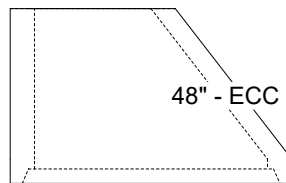
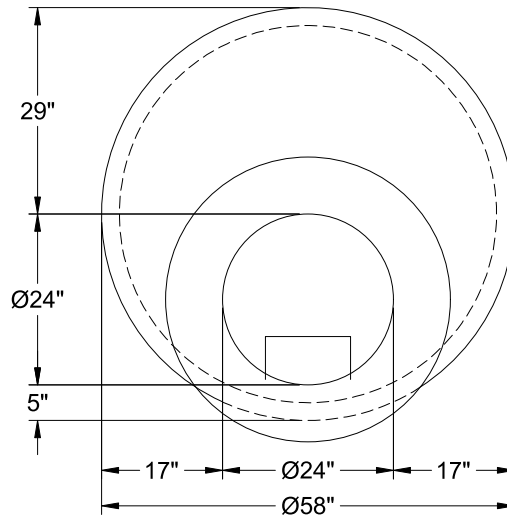

48" - ECC CONE w/ 24" HOLE F/G - 36" - (P2)

Coating (Int):
 Coating (Ext):

Seam Up: Flat
 Seam Dn: Groove

Wall Thickness: 5"

Height (Ext): 36"

Weight (Net): 3000 lb
 Volume (Net): 0.5cu.yd