

Job Name: 25-2943 Shelby Green Ph.2 Sec.3
 Job Location: Junction City, KY
 Contractor: H&S,LLC

Plant: 100

Tech: J. Horsley - A

12/11/2025 1:20:08 PM

PC: Celina Goff



Structure ID: CI-B3

P1 MH048BAVF

MH BASE Custom Ht F/n

- P3) 24" x 24" - CASTING HEIGHT - 5"
- P2) 48" - MH FLAT TOP SPEC. HT. (6") w/24"x24" Hole F/F - 6"
- P1) 48" - MH BASE Custom Ht F/n - 34"
- 1) CASTING - HOE KY-465 SET (CBI TY F)
- 1) 48" - Conseal CS-102 1.00"
- 1) 24" x 24" - Conseal CS-102 1.00"
- 1) Hole - 30
- 1) Hole - 24

0 lb
 1040 lb
 3090 lb
 465 lb
 0 lb
 0 lb
 0 lb
 0 lb

 4595 lb

Structure Total: 4595 lb

- Structure Notes:**
1. PER ASTM C-478 SPECIFICATIONS
 2. CONCRETE: 4,000 PSI AT 28 DAYS
 3. REINFORCEMENT: PER ASTM A615
 4. NO STEPS
 5. HOE KY-465 FRAME, GRATE, & CURB HOOD SUPPLIED BY ICAST

Rim: 1000.76' Rim to Invert: 3.66' Slack: 0.82" Sump: 1.9" Step Position:

Position	Elev	Angle	Ext. (cw)	Pipe	Pipe OD	Connector	Hole	Horz Size	Up (")	Offset
Invert 1	997.1'	0°	0"	24" HDPE	27.8"	Hole 30	30"	32.406", 18.987"	0"	0"
Invert 2	997.1'	155°	78.453"	18" HDPE	21.2"	Hole 24	24"	25.133"	0.3"	0"
Invert 3										
Invert 4										
Invert 5										
Invert 6										
Invert 7										
Invert 8										

RIGHT-SIDE UP VIEW (int. dimensions)

UPSIDE-DOWN VIEW (int. dimensions)

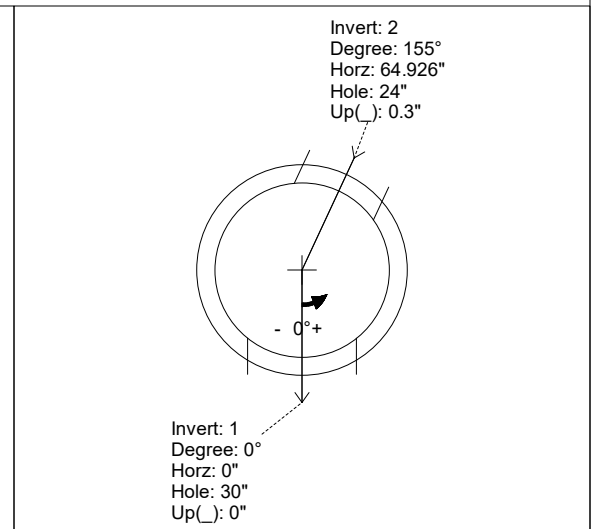
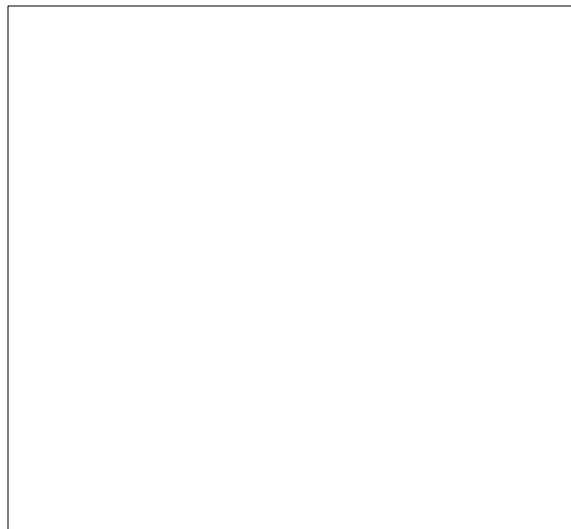
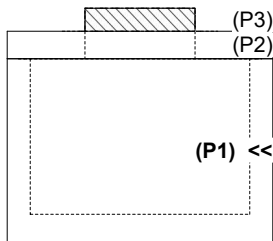

INSIDE WALL DIMENSIONS

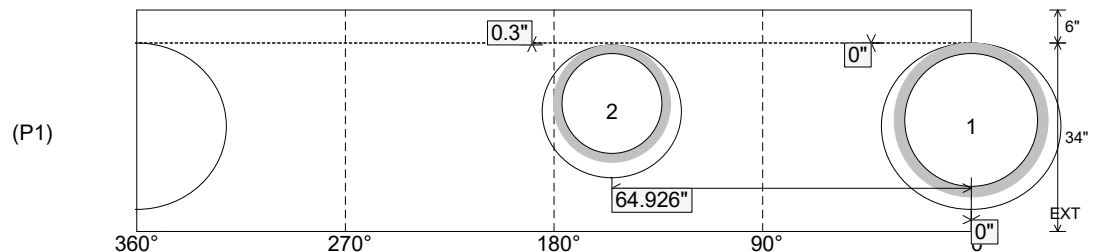

Coating (Int):
 Coating (Ext):

Seam Up: Flat
 Seam Dn: n/a

Wall Thickness: 5"
 Floor Height: 6"

Height (Int): 34"
 Height (Ext): 40"

Weight (Net): 3090 lb
 Volume (Net): 0.79cu.yd