

Job Name: 25-2943 Shelby Green Ph.2 Sec.3 Job Location: Junction City, KY Contractor: H&S,LLC	Plant: 100	Tech: J. Horsley - A	
	12/11/2025 1:20:05 PM	PC: Celina Goff	

Structure ID: CI-A3

P1 BX2424-08BAVF

BOX BASE 8inW, 8inF, Variable Ht F/n

- P2) 24" x 24" - CASTING HEIGHT - 5"
- P1) 24" x 24" - BOX BASE 8inW, 8inF, Variable Ht F/n - 21"
- 1) CASTING - HOE KY-465 SET (CBI TY F)
- 1) 24" x 24" - Conseal CS-102 1.00"
- 1) DOGHOUSE INVRTD - 20"x22"

0 lb
 2500 lb
 465 lb
 0 lb
 0 lb

 Structure Total: 2965 lb

- Structure Notes:
1. PER ASTM C-913 SPECIFICATIONS
 2. CONCRETE: 4,000 PSI AT 28 DAYS
 3. REINFORCEMENT: #5 BAR @ 12" C.C. E.W. (GRADE 60) - 2" MIN. REBAR CLEARANCE (TYP)
 4. HOE KY-465 FRAME, GRATE, & CURB HOOD SUPPLIED BY ICAST

Rim: 998.87' Rim to Invert: 2.17' Slack: 0.04" Sump: 0" Step Position:

Position	Elev	Angle	Ext. (cw)	Pipe	Pipe OD	Connector	Hole	Horz Size	Up ()	Offset
Invert 1	996.7'	45°	40"	15" HDPE	17.6"	DOGHOUSE INVRTD 20"x22"	20" x 22"	14.142", 14.142"	-1.3"	0"
Invert 2										
Invert 3										
Invert 4										
Invert 5										
Invert 6										
Invert 7										
Invert 8										

RIGHT-SIDE UP VIEW (int. dimensions)

UPSIDE-DOWN VIEW (int. dimenions)

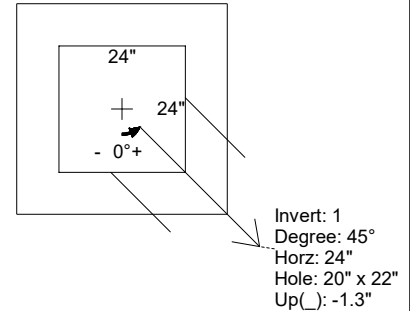
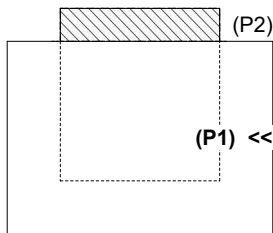

INSIDE WALL DIMENSIONS

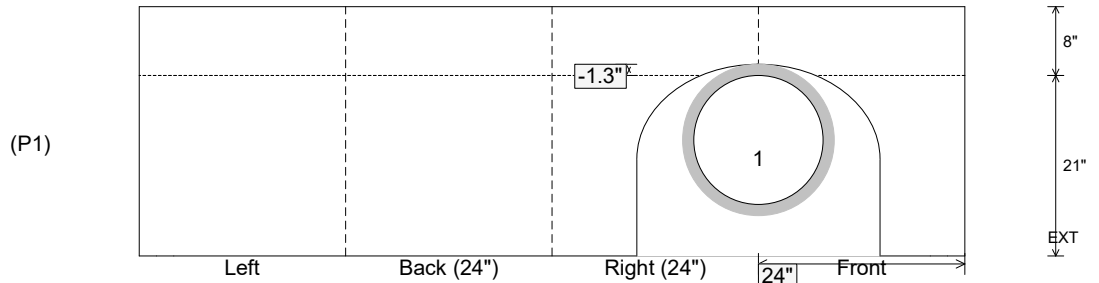

Coating (Int): Coating (Ext):	Seam Up: Flat Seam Dn: n/a	Wall Thickness: 8" Floor Height: 8"	Height (Int): 21" Height (Ext): 29"	Weight (Net): 2500 lb Volume (Net): 0.64cu.yd
----------------------------------	-------------------------------	--	--	--