

TOP VIEW

GENERAL NOTES

1. CONCRETE 28 DAY COMPRESSIVE STRENGTH OF 5000 PSI.
2. REINFORCING PER ASTM A-615:
TOP SLAB: #4 BAR @ 8" C.C.E.W. DBL MAT
BASE #4 @ 8" C.C.E.W
3. VAULT JOINT TO BE SEALED WITH CONSEAL CS-102 ROLL (SUPPLIED BY ICAST).
4. WEIGHT:
TOP SLAB = 5,396 LBS
BASE SECTION = 14,258 LBS
TOTAL = 19,654 LBS

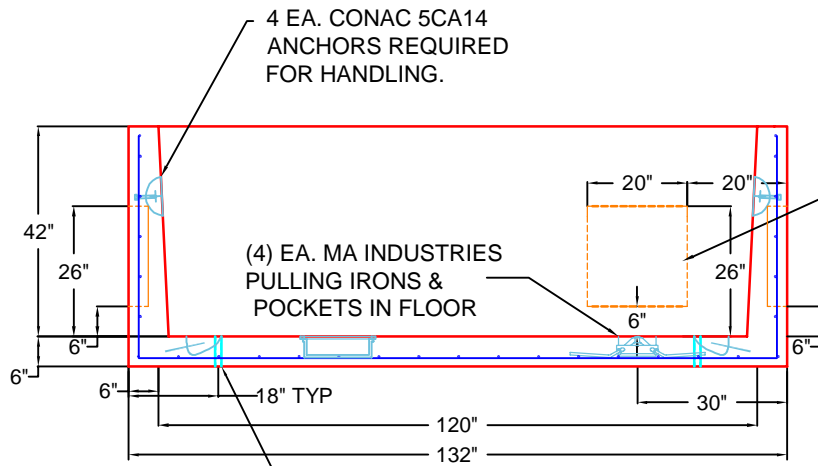

FRONT VIEW

4. EA 20"X20"X4" THICK KNOCK OUT PANEL NEAR AND FAR WALL

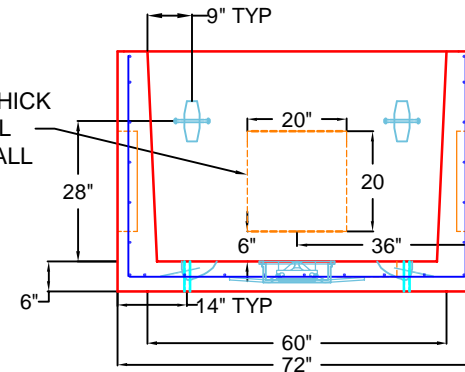

SIDE VIEW

(4) EA 1" PVC CAST IN FLOOR FOR GROUNDING RODS

RIGHT-SIDE UP VIEW

RIGHT-SIDE UP VIEW

REVISION INFORMATION

REV. DATE: NO REVISIONS TO DATE



PRODUCTION DRAWING: 5'X10' SWITCH GEAR PIT BASE		
CUSTOMER: KEMPER CONSTRUCTION		
PROJECT: CVG 200 MLLC		
STRUCTURE: PIT 4		
QUOTE/SALES ORDER NO: 25-2930		
CHK BY: B SMITH	DRAWN BY: C. RUSS	
DATE: 08/12/25	SCALE: NTS	PG. 1 of 1