

Job Name: 25-2898B - Hunter's Ridge Ph.1  
 Job Location: Owensboro, KY  
 Contractor: Ernie Davis & Sons Mechanical, Inc.

Plant: 100  
 12/16/2025 1:57:32 PM

Tech: J. Horsley - F  
 PC: T. Lewis



**Structure ID: MH B-4**

**P3 MH048CN42CDARED**

**ECC CONE w/ 24" HOLE, w/ConBlock-CDA Red F/G**

P5) 24" - CASTING HEIGHT - 7"	0 lb
P4) 24" - GRADE RING w/ConBlock-CDA Red F/F - 4"	270 lb
P3) 48" - ECC CONE w/ 24" HOLE, w/ConBlock-CDA Red F/G - 42"	3116 lb
P2) 48" - MH RISER w/ConBlock-CDA Red T/G - 72"	5030 lb
P1) 48" - MH BASE w/FLANGE (08F/08EF) w/ConBlock-CDA Red T/n - 30"	4914 lb
1) JOINT WRAP - 0.065"x6"x50' CONSEAL CS212	0 lb
1) JOINT WRAP PRIMER - CONSEAL CS-75 (1 gal.)	0 lb
1) ADMIXTURE CONBLOCK CDA RED	0 lb
1) 48" - MH INVERT CHANNEL w/ConBlock-CDA Red - FULL HEIGHT	1440 lb
2) 48" - Conseal CS-102 1.00" (Double)	0 lb
1) PSX - 12-08 NYLO	8 lb
1) PSX - 8QRS-S NYLO	6 lb
12) MH Step ML-10-TDS-NCR - 10"	0 lb
Structure Total:	14784 lb

- Structure Notes:
1. PER ASTM C-478 SPECIFICATIONS
  2. CONCRETE: 4,000 PSI AT 28 DAYS
  3. REINFORCEMENT: PER ASTM A615
  4. INVERT CHANNEL REQUIRED
  5. CONBLOCK CDA RED ADMIXTURE REQUIRED
  6. STEPS AT 268 DEGREES
  7. CASTING BY OTHERS

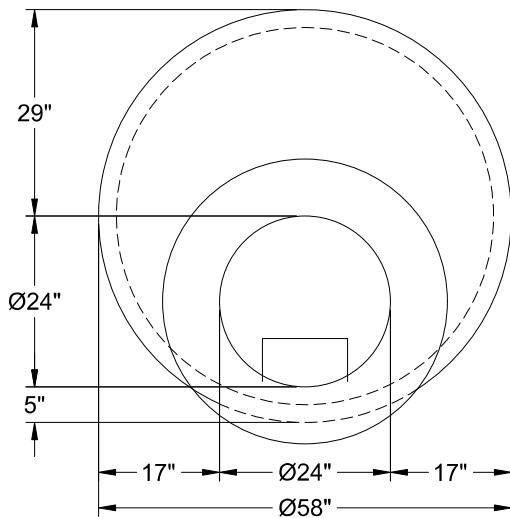

48" - ECC CONE w/ 24" HOLE, w/ConBlock-CDA Red F/G - 42" - (P3)

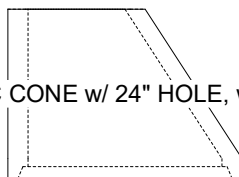

Coating (Int): Coating (Ext):	Seam Up: Flat Seam Dn: Groove	Wall Thickness: 5"	Height (Ext): 42"	Weight (Net): 3116 lb Volume (Net): 0.8cu.yd
----------------------------------	----------------------------------	--------------------	-------------------	---