

Job Name: 25-2898B - Hunter's Ridge Ph.1
 Job Location: Owensboro, KY
 Contractor: Ernie Davis & Sons Mechanical, Inc.

Plant: 100
 12/16/2025 1:57:32 PM

Tech: J. Horsley - F
 PC: T. Lewis



Structure ID: MH B-3

P5 GR4CDARED

GRADE RING w/ConBlock-CDA Red F/F

- P6) 24" - CASTING HEIGHT - 7"
- P5) 24" - GRADE RING w/ConBlock-CDA Red F/F - 4"
- P4) 48" - ECC CONE w/ 24" HOLE, w/ConBlock-CDA Red F/G - 42"
- P3) 48" - MH RISER w/ConBlock-CDA Red T/G - 48"
- P2) 48" - MH RISER w/ConBlock-CDA Red T/G - 48"
- P1) 48" - MH BASE w/FLANGE (08F/08EF) w/ConBlock-CDA Red T/n - 24"
- 1) JOINT WRAP - 0.065"x6"x50" CONSEAL CS212
- 1) JOINT WRAP PRIMER - CONSEAL CS-75 (1 gal.)
- 1) ADMIXTURE CONBLOCK CDA RED
- 1) 48" - MH INVERT CHANNEL w/ConBlock-CDA Red - FULL HEIGHT
- 3) 48" - Conseal CS-102 1.00" (Double)
- 2) PSX - 12-08 NYLO
- 1) PSX - 8QRS-S NYLO
- 14) MH Step ML-10-TDS-NCR - 10"

0 lb
 270 lb
 3116 lb
 3353 lb
 3353 lb
 4447 lb
 0 lb
 0 lb
 0 lb
 1440 lb
 0 lb
 16 lb
 6 lb
 0 lb

 Structure Total: 16002 lb

Structure Notes:

1. PER ASTM C-478 SPECIFICATIONS
2. CONCRETE: 4,000 PSI AT 28 DAYS
3. REINFORCEMENT: (1) #3 HOOP CENTERED (GRADE 60)
4. CONBLOCK CDA RED ADMIXTURE REQUIRED

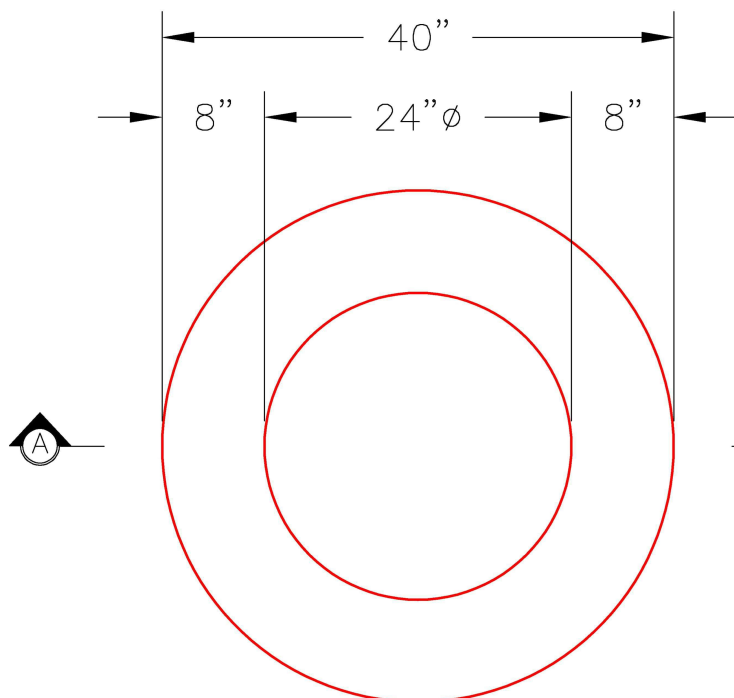

PLAN VIEW

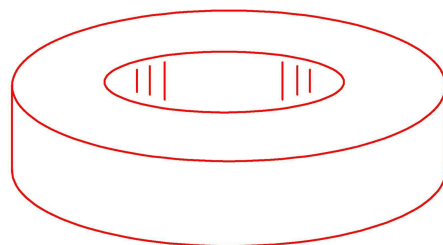

ISOMETRIC VIEW

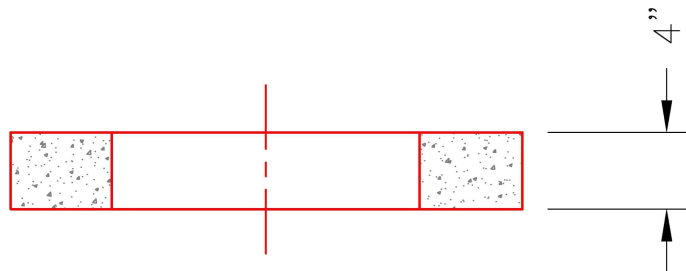

SECTION A-A

Coating (Int):
 Coating (Ext):

Seam Up: Flat
 Seam Dn: Flat

Wall Thickness: 8"

Height (Ext): 4"

Weight (Net): 270 lb
 Volume (Net): 0.07cu.yd