

**Job Name: 25-2898B - Hunter's Ridge Ph.1**  
**Job Location: Owensboro, KY**  
**Contractor: Ernie Davis & Sons Mechanical, Inc.**

PC: T. Lewis  
 TECH: J. Horsley - F  
 Plant: 100



Structure ID: **MH A-8**  
 Spec: Sanitary  
 Type: SAN.MH w/ConBlock-CDA Red  
 Size: 48"

Rim: 425.68'  
 Invert: 414.3'  
 Rim to Invert: 11.38'

Sump: 2"  
 Floor (Top): 414.133'  
 Floor Height: 6"

Floor (Bot): 413.633'  
 Overall Height: 11.917'  
 Slack: 1.56"

- Structure Notes:**
1. PER ASTM C-478 SPECIFICATIONS
  2. CONCRETE: 4,000 PSI AT 28 DAYS
  3. REINFORCEMENT: PER ASTM A615
  4. INVERT CHANNEL REQUIRED
  5. CONBLOCK CDA RED ADMIXTURE REQUIRED
  6. STEPS AT 88.5 DEGREES
  7. CASTING BY OTHERS

**STRUCTURE SUMMARY:**

- P5) 24" - CASTING HEIGHT - 7" 0 lb
  - P4) 24" - GRADE RING w/ConBlock-CDA Red F/F - 4" 270 lb
  - P3) 48" - ECC CONE w/ 24" HOLE, w/ConBlock-CDA Red F/G - 36" 2251 lb
  - P2) 48" - MH RISER w/ConBlock-CDA Red T/G - 60" 4192 lb
  - P1) 48" - MH BASE w/ConBlock-CDA Red T/n - 30" 3282 lb
  - 1) JOINT WRAP - 0.065"x6"x50' CONSEAL CS212 0 lb
  - 1) JOINT WRAP PRIMER - CONSEAL CS-75 (1 gal.) 0 lb
  - 1) ADMIXTURE CONBLOCK CDA RED 0 lb
  - 1) 48" - MH INVERT CHANNEL w/ConBlock-CDA Red - FULL HEIGHT 1440 lb
  - 2) 48" - Conseal CS-102 1.00" (Double) 0 lb
  - 3) PSX - 12-08 NYLO 24 lb
  - 10) MH Step ML-10-TDS-NCR - 10" 0 lb
- Structure Total: 11459 lb

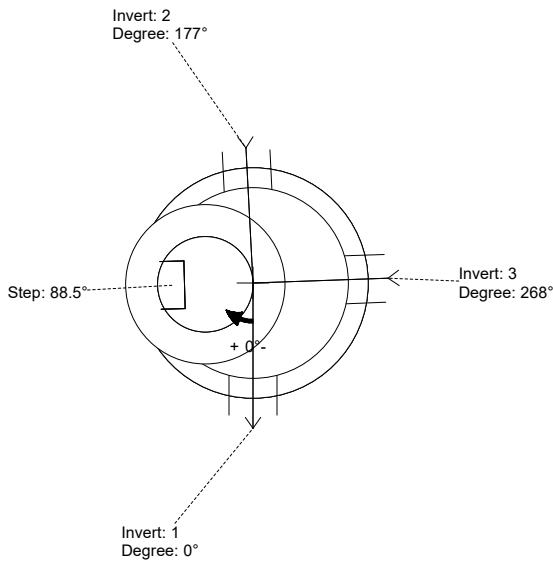

Position	Elev	Angle	Pipe	Pipe OD	Hole	Connector	Up (L)	Ref
Rim	425.68'							
Reducer								
Invert 1	414.3'	0°	8" PVC SDR26	8.5"	12"	PSX 12-08 NYLO	0"	P1
Invert 2	414.4'	177°	8" PVC SDR35	8.5"	12"	PSX 12-08 NYLO	1.2"	P1
Invert 3	414.4'	268°	8" PVC SDR35	8.5"	12"	PSX 12-08 NYLO	1.2"	P1
Invert 4								
Invert 5								
Invert 6								
Invert 7								
Invert 8								

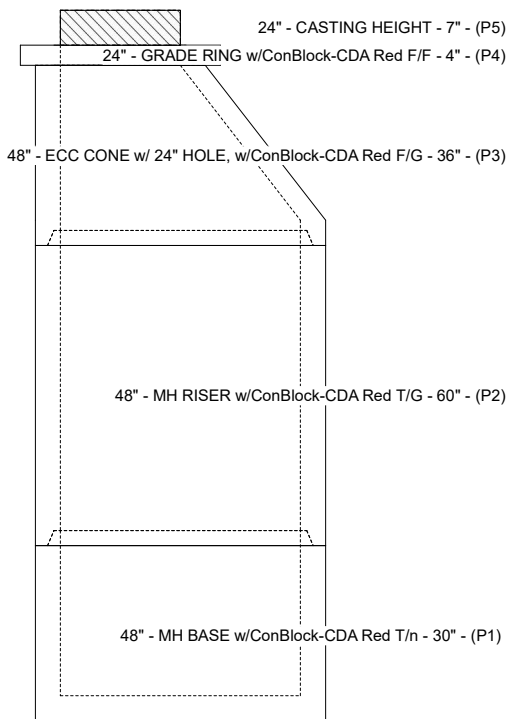

**Cast (Int. Dim.) - Interior Dimensions**

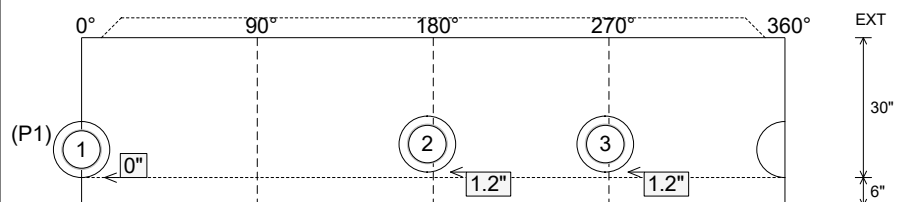

Submittal Drawing  
 12/16/2025 1:48:06 PM

SUBMITTAL  
 APPROVED BY: