

Job Name: 25-2898B - Hunter's Ridge Ph.1
 Job Location: Owensboro, KY
 Contractor: Ernie Davis & Sons Mechanical, Inc.

Plant: 100
 12/16/2025 1:56:49 PM

Tech: J. Horsley - F
 PC: T. Lewis



Structure ID: MH A-7

P1 MH048BAEVFCDARED

MH BASE w/FLANGE (08F/08EF) w/ConBlock-CDA Red F/n

P5) 24" - CASTING HEIGHT - 7"	0 lb
P4) 48" - ECC CONE w/ 24" HOLE, w/ConBlock-CDA Red F/G - 42"	3116 lb
P3) 48" - MH RISER w/ConBlock-CDA Red T/G - 60"	4192 lb
P2) 48" - MH RISER w/ConBlock-CDA Red T/G - 60"	4192 lb
P1) 48" - MH BASE w/FLANGE (08F/08EF) w/ConBlock-CDA Red T/n - 30"	4818 lb
1) JOINT WRAP - 0.065"x6"x50' CONSEAL CS212	0 lb
1) JOINT WRAP PRIMER - CONSEAL CS-75 (1 gal.)	0 lb
1) ADMIXTURE CONBLOCK CDA RED	0 lb
1) 48" - MH INVERT CHANNEL w/ConBlock-CDA Red - FULL HEIGHT	1440 lb
3) 48" - Conseal CS-102 1.00" (Double)	0 lb
3) PSX - 12-08 NYLO	24 lb
1) PSX - 8QRS-S NYLO	6 lb
16) MH Step ML-10-TDS-NCR - 10"	0 lb
Structure Total:	17788 lb

- Structure Notes:**
- PER ASTM C-478 SPECIFICATIONS
 - CONCRETE: 4,000 PSI AT 28 DAYS
 - REINFORCEMENT: PER ASTM A615
 - INVERT CHANNEL REQUIRED
 - CONBLOCK CDA RED ADMIXTURE REQUIRED
 - STEPS AT 45 DEGREES
 - CASTING BY OTHERS

Rim: 429.93' Rim to Invert: 16.53' Slack: 1.36" Sump: 2" Step Position: 45°

Position	Elev	Angle	Ext. (cw)	Pipe	Pipe OD	Connector	Hole	Horz Size	Up ()	Offset
Invert 1	413.4'	0°	0"	8" PVC SDR26	8.5"	PSX 12-08 NYLO	12"	12.129"	0"	0"
Invert 2	413.5'	90°	45.553"	8" PVC SDR26	8.5"	PSX 12-08 NYLO	12"	12.129"	1.2"	0"
Invert 3	413.5'	180°	91.106"	4" PVC SDR35	4.25"	PSX 8QRS-S NYLO	8"	8.038"	1.2"	0"
Invert 4	413.5'	270°	136.659"	8" PVC SDR26	8.5"	PSX 12-08 NYLO	12"	12.129"	1.2"	0"
Invert 5										
Invert 6										
Invert 7										
Invert 8										

RIGHT-SIDE UP VIEW (int. dimensions)

UPSIDE-DOWN VIEW (int. dimensions)

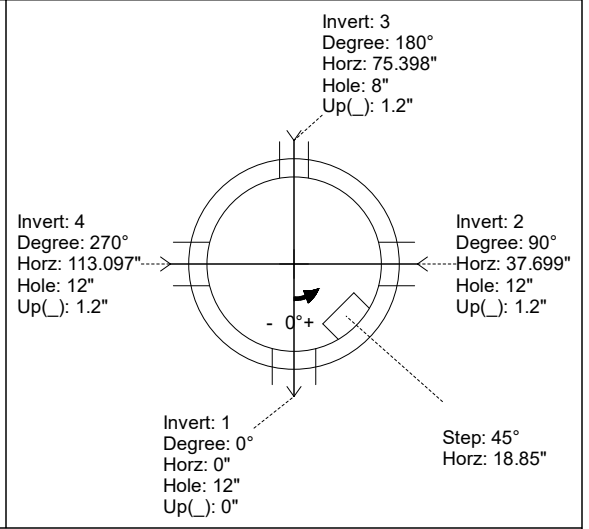
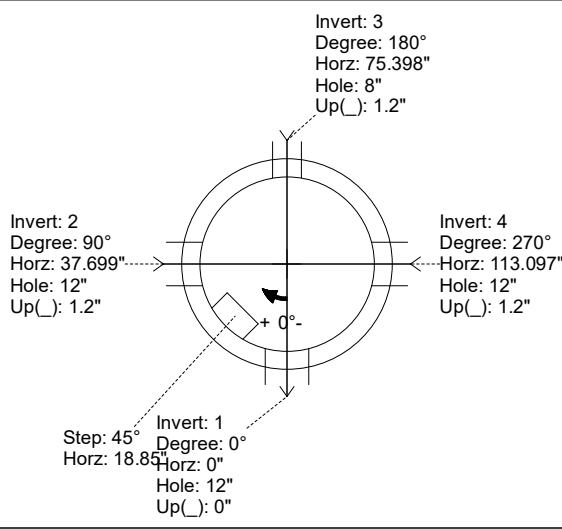
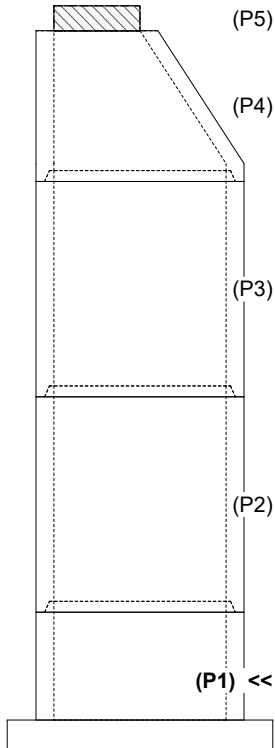

INSIDE WALL DIMENSIONS

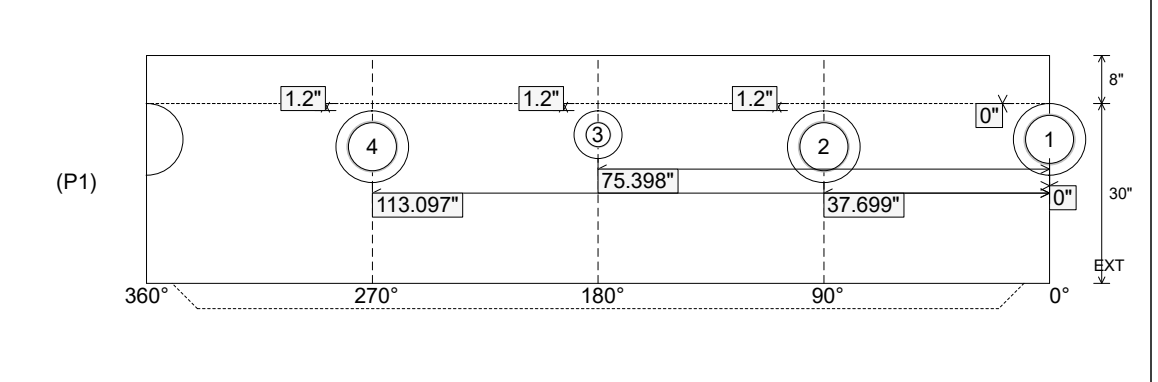

Coating (Int): Coating (Ext):	Seam Up: Tongue Seam Dn: n/a	Wall Thickness: 5" Floor Height: 8"	Height (Int): 30" Height (Ext): 38"	Weight (Net): 4818 lb Volume (Net): 1.23cu.yd
----------------------------------	---------------------------------	--	--	--

Job Name: 25-2898B - Hunter's Ridge Ph.1
 Job Location: Owensboro, KY
 Contractor: Ernie Davis & Sons Mechanical, Inc.

Plant: 100
 12/16/2025 1:56:49 PM

Tech: J. Horsley - F
 PC: T. Lewis



Structure ID: MH A-7

P1 MH048BAEVFCDARED

MH BASE w/FLANGE (08F/08EF) w/ConBlock-CDA Red F/G

P5) 24" - CASTING HEIGHT - 7"	0 lb
P4) 48" - ECC CONE w/ 24" HOLE, w/ConBlock-CDA Red F/G - 42"	3116 lb
P3) 48" - MH RISER w/ConBlock-CDA Red T/G - 60"	4192 lb
P2) 48" - MH RISER w/ConBlock-CDA Red T/G - 60"	4192 lb
P1) 48" - MH BASE w/FLANGE (08F/08EF) w/ConBlock-CDA Red T/n - 30"	4818 lb
1) JOINT WRAP - 0.065"x6"x50' CONSEAL CS212	0 lb
1) JOINT WRAP PRIMER - CONSEAL CS-75 (1 gal.)	0 lb
1) ADMIXTURE CONBLOCK CDA RED	0 lb
1) 48" - MH INVERT CHANNEL w/ConBlock-CDA Red - FULL HEIGHT	1440 lb
3) 48" - Conseal CS-102 1.00" (Double)	0 lb
3) PSX - 12-08 NYLO	24 lb
1) PSX - 8QRS-S NYLO	6 lb
16) MH Step ML-10-TDS-NCR - 10"	0 lb
Structure Total:	17788 lb

- Structure Notes:**
- PER ASTM C-478 SPECIFICATIONS
 - CONCRETE: 4,000 PSI AT 28 DAYS
 - REINFORCEMENT: PER ASTM A615
 - INVERT CHANNEL REQUIRED
 - CONBLOCK CDA RED ADMIXTURE REQUIRED
 - STEPS AT 45 DEGREES
 - CASTING BY OTHERS

Rim: 429.93' Rim to Invert: 16.53' Slack: 1.36" Sump: 2" Step Position: 45°

Position	Elev	Angle	Ext. (cw)	Pipe	Pipe OD	Connector	Hole	Horz Size	Up ()	Offset
Invert 1	413.4'	0°	0"	8" PVC SDR26	8.5"	PSX 12-08 NYLO	12"	12.129"	0"	0"
Invert 2	413.5'	90°	45.553"	8" PVC SDR26	8.5"	PSX 12-08 NYLO	12"	12.129"	1.2"	0"
Invert 3	413.5'	180°	91.106"	4" PVC SDR35	4.25"	PSX 8QRS-S NYLO	8"	8.038"	1.2"	0"
Invert 4	413.5'	270°	136.659"	8" PVC SDR26	8.5"	PSX 12-08 NYLO	12"	12.129"	1.2"	0"
Invert 5										
Invert 6										
Invert 7										
Invert 8										

RIGHT-SIDE UP VIEW (int. dimensions)

UPSIDE-DOWN VIEW (int. dimenions)

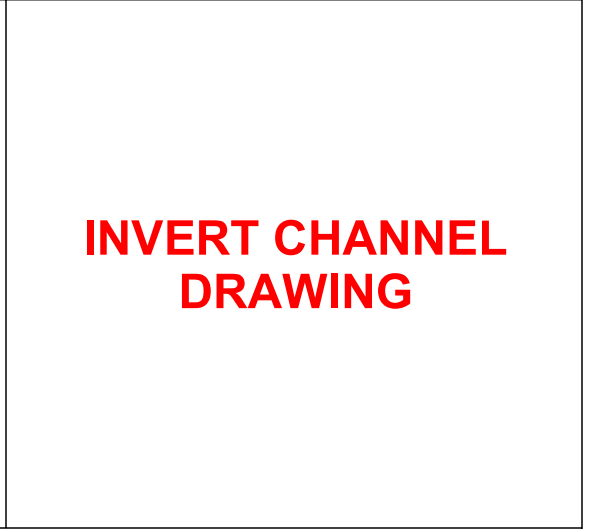
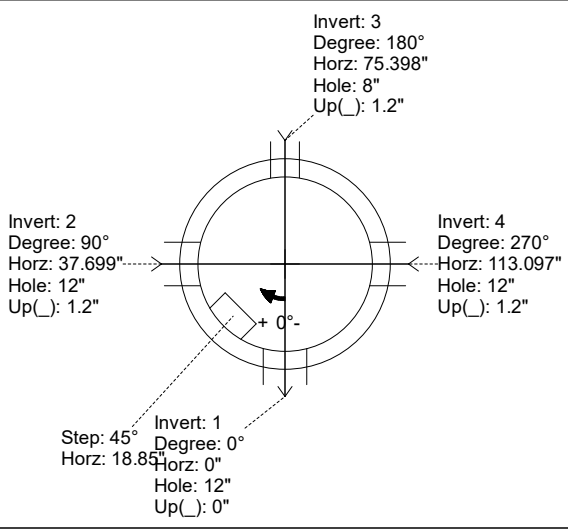
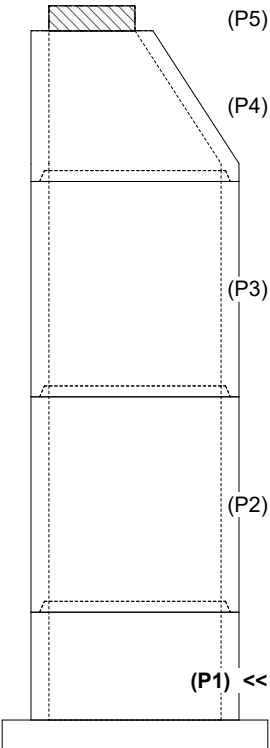

INSIDE WALL DIMENSIONS

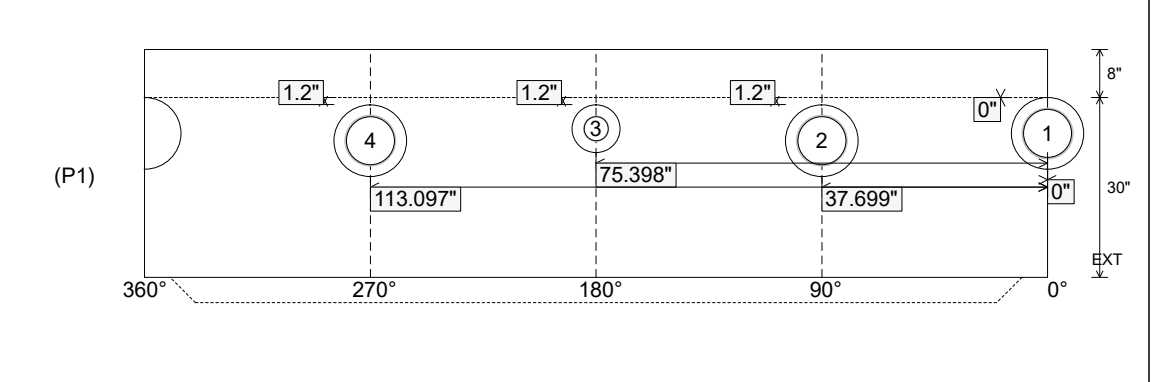

Coating (Int): Coating (Ext):	Seam Up: Tongue Seam Dn: n/a	Wall Thickness: 5" Floor Height: 8"	Height (Int): 30" Height (Ext): 38"	Weight (Net): 4818 lb Volume (Net): 1.23cu.yd
----------------------------------	---------------------------------	--	--	--