

Job Name: 25-2898B - Hunter's Ridge Ph.1
Job Location: Owensboro, KY
Contractor: Ernie Davis & Sons Mechanical, Inc.

PC: T. Lewis
 TECH: J. Horsley - F
 Plant: 100



Structure ID: **MH A-5**
 Spec: Sanitary
 Type: SAN.MH w/ConBlock-CDA Red
 Size: 48"

Rim: 422'
 Invert: 411.35'
 Rim to Invert: 10.65'

Sump: 2"
 Floor (Top): 411.183'
 Floor Height: 6"

Floor (Bot): 410.683'
 Overall Height: 11.083'
 Slack: 2.8"

Structure Notes:

1. PER ASTM C-478 SPECIFICATIONS
2. CONCRETE: 4,000 PSI AT 28 DAYS
3. REINFORCEMENT: PER ASTM A615
4. INVERT CHANNEL REQUIRED
5. CONBLOCK CDA RED ADMIXTURE REQUIRED
6. STEPS AT 254 DEGREES
7. CASTING BY OTHERS

STRUCTURE SUMMARY:

| | |
|--------------------------------------------------------------|-----------------|
| P4) 24" - CASTING HEIGHT - 7" | 0 lb |
| P3) 48" - ECC CONE w/ 24" HOLE, w/ConBlock-CDA Red F/G - 36" | 2251 lb |
| P2) 48" - MH RISER w/ConBlock-CDA Red T/G - 60" | 4192 lb |
| P1) 48" - MH BASE w/ConBlock-CDA Red T/n - 24" | 2911 lb |
| 1) JOINT WRAP - 0.065"x6"x50' CONSEAL CS212 | 0 lb |
| 1) JOINT WRAP PRIMER - CONSEAL CS-75 (1 gal.) | 0 lb |
| 1) ADMIXTURE CONBLOCK CDA RED | 0 lb |
| 1) 48" - MH INVERT CHANNEL w/ConBlock-CDA Red - FULL HEIGHT | 1440 lb |
| 2) 48" - Con Seal CS-102 1.00" (Double) | 0 lb |
| 2) PSX - 12-08 NYLO | 16 lb |
| 10) MH Step ML-10-TDS-NCR - 10" | 0 lb |
| Structure Total: | 10810 lb |

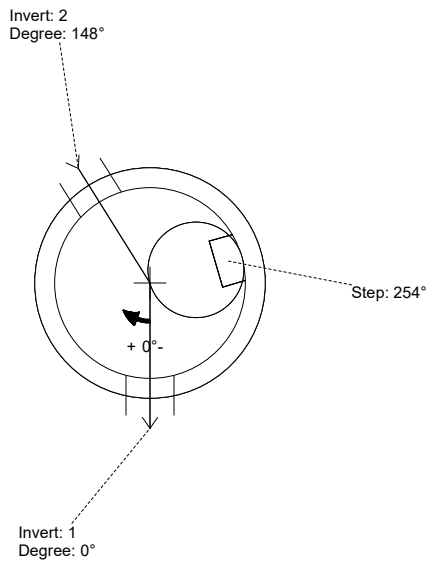

| Position | Elev | Angle | Pipe | Pipe OD | Hole | Connector | Up (L) | Ref |
|----------|---------|-------|--------------|---------|------|----------------|--------|-----|
| Rim | 422' | | | | | | | |
| Reducer | | | | | | | | |
| Invert 1 | 411.35' | 0° | 8" PVC SDR35 | 8.5" | 12" | PSX 12-08 NYLO | 0" | P1 |
| Invert 2 | 411.45' | 148° | 8" PVC SDR35 | 8.5" | 12" | PSX 12-08 NYLO | 1.2" | P1 |
| Invert 3 | | | | | | | | |
| Invert 4 | | | | | | | | |
| Invert 5 | | | | | | | | |
| Invert 6 | | | | | | | | |
| Invert 7 | | | | | | | | |
| Invert 8 | | | | | | | | |

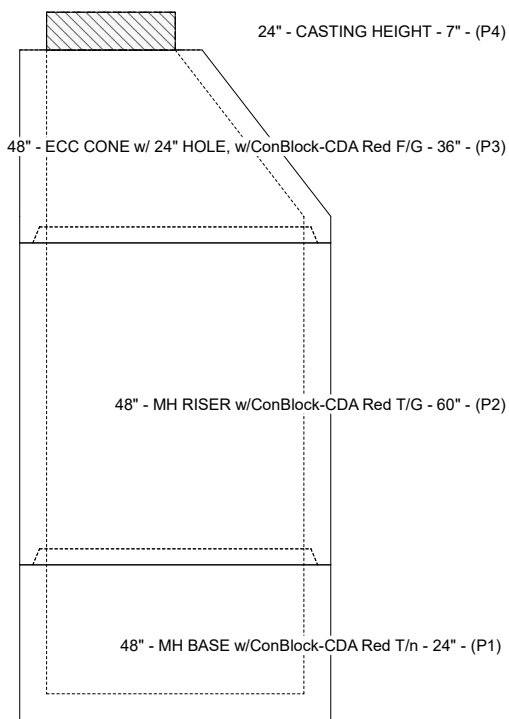

Cast (Int. Dim.) - Interior Dimensions

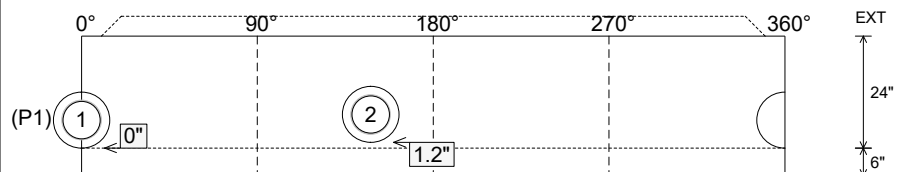

Submittal Drawing
 12/16/2025 1:48:04 PM

SUBMITTAL
 APPROVED BY: