

Structure ID: MH A-5

P1 MH048BA24CDARED

MH BASE w/ConBlock-CDA Red T/n

P4) 24" - CASTING HEIGHT - 7" P3) 48" - ECC CONE w/ 24" HOLE, w/ConBlock-CDA Red F/G - 36" P2) 48" - MH RISER w/ConBlock-CDA Red T/G - 60" P1) 48" - MH BASE w/ConBlock-CDA Red T/n - 24" 1) JOINT WRAP - 0.065"x6"x50" CONSEAL CS212 1) JOINT WRAP PRIMER - CONSEAL CS-75 (1 gal.) 1) ADMIXTURE CONBLOCK CDA RED 1) 48" - MH INVERT CHANNEL w/ConBlock-CDA Red - FULL HEIGHT 2) 48" - Con Seal CS-102 1.00" (Double) 2) PSX - 12-08 NYLO 10) MH Step ML-10-TDS-NCR - 10"	<table style="width:100%; border-collapse: collapse;"> <tr><td style="text-align: right;">0 lb</td><td></td></tr> <tr><td style="text-align: right;">2251 lb</td><td></td></tr> <tr><td style="text-align: right;">4192 lb</td><td></td></tr> <tr><td style="text-align: right;">2911 lb</td><td></td></tr> <tr><td style="text-align: right;">0 lb</td><td></td></tr> <tr><td style="text-align: right;">0 lb</td><td></td></tr> <tr><td style="text-align: right;">0 lb</td><td></td></tr> <tr><td style="text-align: right;">1440 lb</td><td></td></tr> <tr><td style="text-align: right;">0 lb</td><td></td></tr> <tr><td style="text-align: right;">16 lb</td><td></td></tr> <tr><td style="text-align: right;">0 lb</td><td></td></tr> <tr><td style="text-align: right;">-----</td><td></td></tr> <tr><td style="text-align: right;">Structure Total:</td><td style="text-align: right;">10810 lb</td></tr> </table>	0 lb		2251 lb		4192 lb		2911 lb		0 lb		0 lb		0 lb		1440 lb		0 lb		16 lb		0 lb		-----		Structure Total:	10810 lb
0 lb																											
2251 lb																											
4192 lb																											
2911 lb																											
0 lb																											
0 lb																											
0 lb																											
1440 lb																											
0 lb																											
16 lb																											
0 lb																											

Structure Total:	10810 lb																										

Structure Notes:

1. PER ASTM C-478 SPECIFICATIONS
2. CONCRETE: 4,000 PSI AT 28 DAYS
3. REINFORCEMENT: PER ASTM A615
4. INVERT CHANNEL REQUIRED
5. CONBLOCK CDA RED ADMIXTURE REQUIRED
6. STEPS AT 254 DEGREES
7. CASTING BY OTHERS

Rim: 422' Rim to Invert: 10.65' Slack: 2.8" Sump: 2" Step Position: 254°

Position	Elev	Angle	Ext. (cw)	Pipe	Pipe OD	Connector	Hole	Horz Size	Up ()	Offset
Invert 1	411.35'	0°	0"	8" PVC SDR35	8.5"	PSX 12-08 NYLO	12"	12.129"	0"	0"
Invert 2	411.45'	148°	74.91"	8" PVC SDR35	8.5"	PSX 12-08 NYLO	12"	12.129"	1.2"	0"
Invert 3										
Invert 4										
Invert 5										
Invert 6										
Invert 7										
Invert 8										

RIGHT-SIDE UP VIEW (int. dimensions)

UPSIDE-DOWN VIEW (int. dimensions)

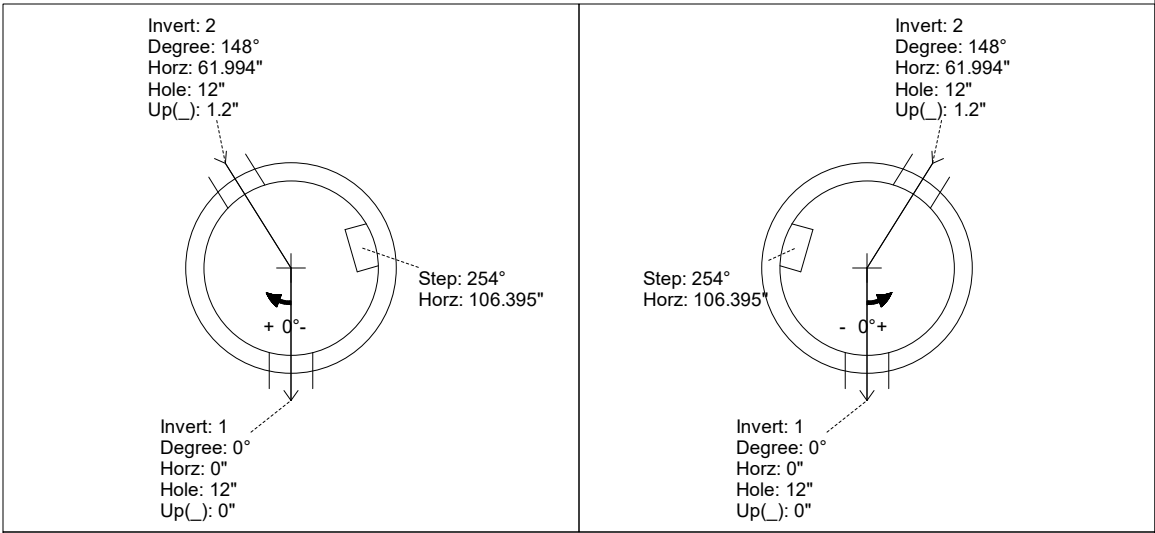

INSIDE WALL DIMENSIONS

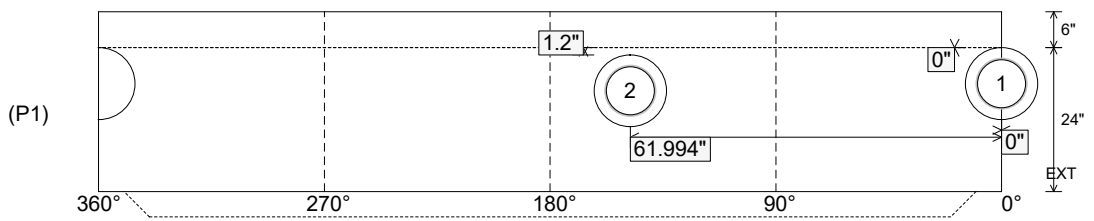

Coating (Int): Coating (Ext):	Seam Up: Tongue Seam Dn: n/a	Wall Thickness: 5" Floor Height: 6"	Height (Int): 24" Height (Ext): 30"	Weight (Net): 2911 lb Volume (Net): 0.74cu.yd
----------------------------------	---------------------------------	--	--	--

Structure ID: MH A-5

P1 MH048BA24CDARED

MH BASE w/ConBlock-CDA Red T/n

P4) 24" - CASTING HEIGHT - 7" P3) 48" - ECC CONE w/ 24" HOLE, w/ConBlock-CDA Red F/G - 36" P2) 48" - MH RISER w/ConBlock-CDA Red T/G - 60" P1) 48" - MH BASE w/ConBlock-CDA Red T/n - 24" 1) JOINT WRAP - 0.065"x6"x50" CONSEAL CS212 1) JOINT WRAP PRIMER - CONSEAL CS-75 (1 gal.) 1) ADMIXTURE CONBLOCK CDA RED 1) 48" - MH INVERT CHANNEL w/ConBlock-CDA Red - FULL HEIGHT 2) 48" - Con Seal CS-102 1.00" (Double) 2) PSX - 12-08 NYLO 10) MH Step ML-10-TDS-NCR - 10"	0 lb 2251 lb 4192 lb 2911 lb 0 lb 0 lb 0 lb 1440 lb 0 lb 16 lb 0 lb <hr style="width: 50px; margin-left: auto; margin-right: 0;"/> Structure Total: 10810 lb
---	---

Structure Notes:

1. PER ASTM C-478 SPECIFICATIONS
2. CONCRETE: 4,000 PSI AT 28 DAYS
3. REINFORCEMENT: PER ASTM A615
4. INVERT CHANNEL REQUIRED
5. CONBLOCK CDA RED ADMIXTURE REQUIRED
6. STEPS AT 254 DEGREES
7. CASTING BY OTHERS

Rim: 422' Rim to Invert: 10.65' Slack: 2.8" Sump: 2" Step Position: 254°

Position	Elev	Angle	Ext. (cw)	Pipe	Pipe OD	Connector	Hole	Horz Size	Up ()	Offset
Invert 1	411.35'	0°	0"	8" PVC SDR35	8.5"	PSX 12-08 NYLO	12"	12.129"	0"	0"
Invert 2	411.45'	148°	74.91"	8" PVC SDR35	8.5"	PSX 12-08 NYLO	12"	12.129"	1.2"	0"
Invert 3										
Invert 4										
Invert 5										
Invert 6										
Invert 7										
Invert 8										

RIGHT-SIDE UP VIEW (int. dimensions)

UPSIDE-DOWN VIEW (int. dimenions)

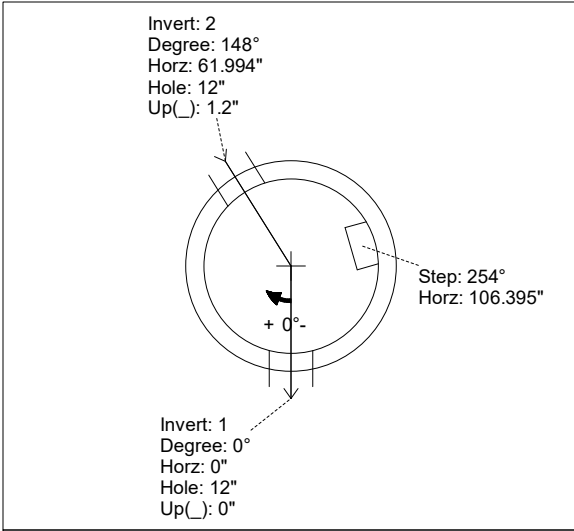
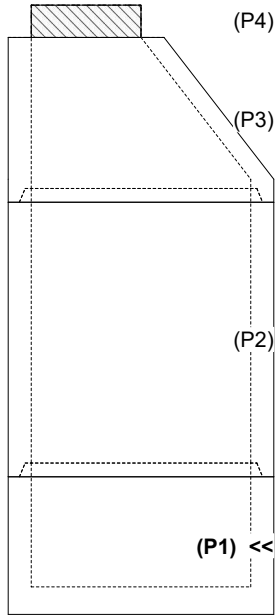

INSIDE WALL DIMENSIONS

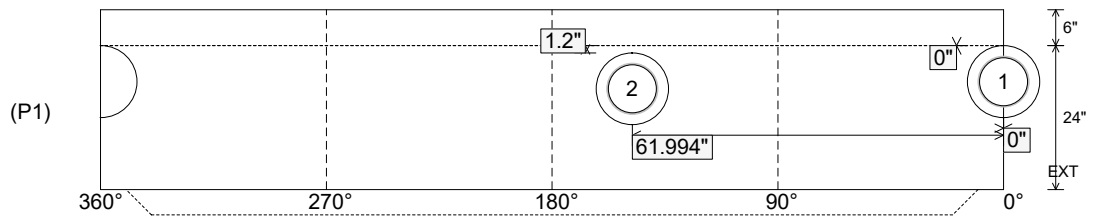

Coating (Int): Coating (Ext):	Seam Up: Tongue Seam Dn: n/a	Wall Thickness: 5" Floor Height: 6"	Height (Int): 24" Height (Ext): 30"	Weight (Net): 2911 lb Volume (Net): 0.74cu.yd
----------------------------------	---------------------------------	--	--	--