

Job Name: 25-2898B - Hunter's Ridge Ph.1
 Job Location: Owensboro, KY
 Contractor: Ernie Davis & Sons Mechanical, Inc.

Plant: 100

12/16/2025 1:57:27 PM

Tech: J. Horsley - F

PC: T. Lewis



Structure ID: MH A-3

P3 MH048CN24CDARED

ECC CONE w/ 24" HOLE, w/ConBlock-CDA Red F/G

P5) 24" - CASTING HEIGHT - 7"	0 lb
P4) 24" - GRADE RING w/ConBlock-CDA Red F/F - 3"	202 lb
P3) 48" - ECC CONE w/ 24" HOLE, w/ConBlock-CDA Red F/G - 24"	1738 lb
P2) 48" - MH RISER w/ConBlock-CDA Red T/G - 36"	2515 lb
P1) 48" - MH BASE w/ConBlock-CDA Red T/n - 24"	2911 lb
1) JOINT WRAP - 0.065"x6"x50' CONSEAL CS212	0 lb
1) JOINT WRAP PRIMER - CONSEAL CS-75 (1 gal.)	0 lb
1) ADMIXTURE CONBLOCK CDA RED	0 lb
1) 48" - MH INVERT CHANNEL w/ConBlock-CDA Red - FULL HEIGHT	1440 lb
2) 48" - Conseal CS-102 1.00" (Double)	0 lb
2) PSX - 12-08 NYLO	16 lb
7) MH Step ML-10-TDS-NCR - 10"	0 lb
Structure Total:	8823 lb

- Structure Notes:**
1. PER ASTM C-478 SPECIFICATIONS
 2. CONCRETE: 4,000 PSI AT 28 DAYS
 3. REINFORCEMENT: PER ASTM A615
 4. INVERT CHANNEL REQUIRED
 5. CONBLOCK CDA RED ADMIXTURE REQUIRED
 6. STEPS AT 109 DEGREES
 7. CASTING BY OTHERS

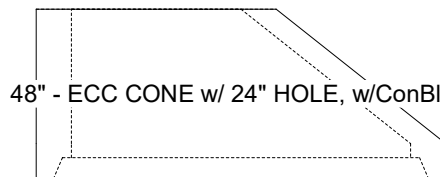
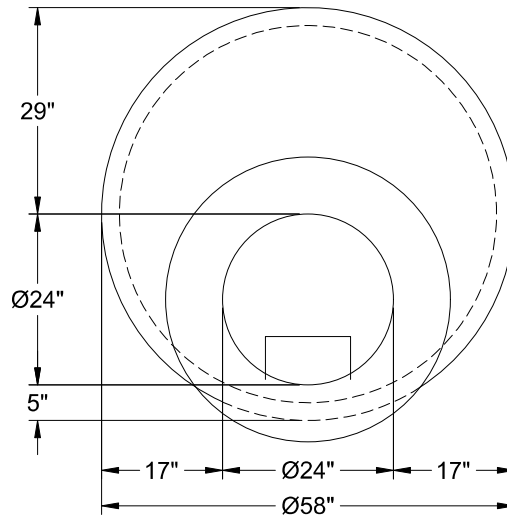

48" - ECC CONE w/ 24" HOLE, w/ConBlock-CDA Red F/G - 24" - (P3)

Coating (Int):
 Coating (Ext):

Seam Up: Flat
 Seam Dn: Groove

Wall Thickness: 5"

Height (Ext): 24"

Weight (Net): 1738 lb
 Volume (Net): 0.44cu.yd