

Job Name: 25-2868 USI Wright Admin Renovation  
 Job Location: Evansville, IN  
 Contractor: Empire Contractors, Inc.

Plant: Beaver Dam  
 2/2/2026 10:32:10 AM

Tech: J. Coppage  
 PC: C. Goff



**Structure ID: 303**

**P2 MH048RS672SCDARED**

**MH RISER w/DROP/ConBlock-CDA Red**

- P5) 24" - CASTING HEIGHT - 7" 0 lb
- P4) 24" - GRADE RING w/ConBlock-CDA Red - 4" 270 lb
- P3) 48" - ECC CONE w/ 24" HOLE, w/ConBlock-CDA Red - 36" 2251 lb
- P2) 48" - MH RISER w/DROP/ConBlock-CDA Red - 72" 5016 lb
- P1) 48" - MH BASE w/DROP/ConBlock-CDA Red - 30" 3364 lb
- 1) JOINT WRAP - 0.065"x6"x50' CONSEAL CS212 0 lb
- 1) JOINT WRAP PRIMER - CONSEAL CS-75 (1 gal.) 0 lb
- 1) 48" - MH INVERT CHANNEL EWSU w/ConBlock-CDA Red - FULL HEIGHT 1440 lb
- 2) 48" - Conseal CS-102 1.00" (Double) 0 lb
- 1) PSX - 12-06 NYLO 8 lb
- 2) Drop Tee - 6" PVC 0 lb

- Structure Notes:**
1. JR HOE MC-315 SANITARY PROVIDED BY ICAST.
  2. PER ASTM C478 SPECIFICATIONS.
  3. CONCRETE = 4,000 PSI AT 28 DAYS.
  4. ADMIXTURE = CONBLOCK CDA RED.
  5. REINFORCING PER ASTM A615 (GRADE 60).  
 - CONE (As .12)  
 - RISER/WALLS (As .12)  
 - FLOOR (As .31) #5 BARS AT 12" C.C.E.W.
  6. NO STEPS
  7. EWSU STYLE INVERT CHANNEL TO BE PROVIDED.

Structure Total: 12349 lb

Rim: 485' Rim to Invert: 12.32' Slack: 1.773' Sump: 2.933' Step Position:

Position	Elev	Angle	Ext. (cw)	Pipe	Pipe OD	Connector	Hole	Horz Size	Up ( )	Offset
Invert 1										
Invert 2	479.6'	180°	91.106"	6" PVC SDR26	6.25"	Drop Tee 6" PVC	6.5"	6.52"	51.473"	0"
Invert 3										
Invert 4										
Invert 5										
Invert 6										
Invert 7										
Invert 8										

**RIGHT-SIDE UP VIEW (int. dimensions)**

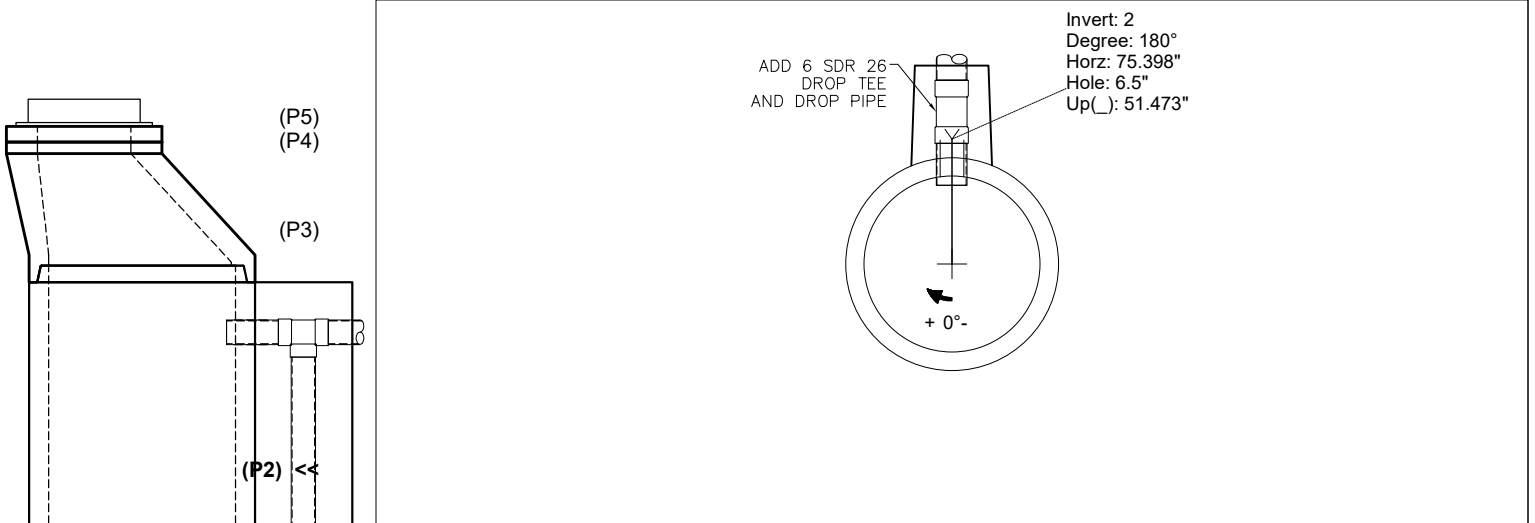

**INSIDE WALL DIMENSIONS**

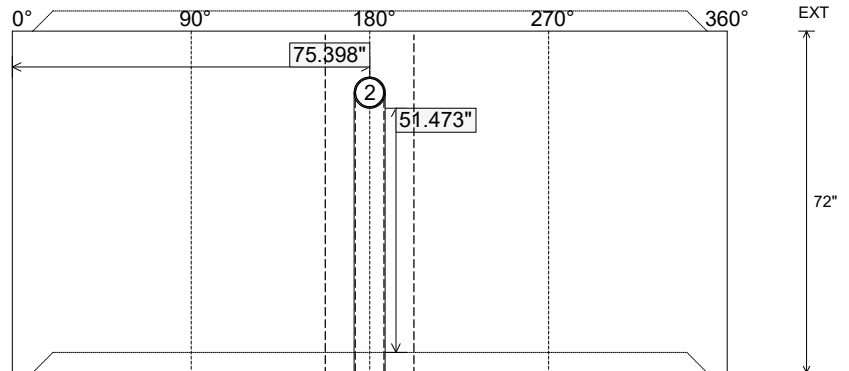

Coating (Int): Coating (Ext):	Seam Up: Tongue Seam Dn: Groove	Wall Thickness: 5" Floor Height: 0"	Height (Int): 72" Height (Ext): 72"	Weight (Net): 5016 lb Volume (Net): 1.28cu.yd
----------------------------------	------------------------------------	--	--	--