

Job Name: 25-2861 Spencer Co Bus Garage	Plant: Beaver Dam	Tech: C.Russ	
Job Location: Taylorsville, Ky Contractor: Louisville Paving and Construction	10/22/2025 10:49:24 AM	PC: J.Jarvis	

Structure ID: HW 1

P1 HWSF12

SLOPED & FLARED HEADWALL F/F

P1) 12" - SLOPED & FLARED HEADWALL F/F - 12"
 1) CASTING - HOE 280T F/G

3037 lb
 182 lb
 Structure Total: 3219 lb

- Structure Notes:**
- PER ASTM C478 SPECIFICATIONS.
 - CONCRETE = 4,000 PSI AT 28 DAYS.
 - HOE 280T PROVIDED BY ICAST.
 - REINFORCING PER ASTM A615 (GRADE 60).
 - TOP SLAB (As .62) #5 BARS AT 6" C.C.E.W..
 - RISER/WALLS (As .12)
 - FLOOR (As .31) #5 BARS AT 12" C.C.E.W.

Rim: 0' Rim to Invert: 0' Slack: 0" Sump: 12" Step Position: 90°

Position	Elev	Angle	Ext. (cw)	Pipe	Pipe OD	Connector	Hole	Horz Size	Up (L)	Offset
Invert 1										
Invert 2										
Invert 3										
Invert 4										
Invert 5										
Invert 6										
Invert 7										
Invert 8										

RIGHT-SIDE UP VIEW (int. dimensions)

UPSIDE-DOWN VIEW (int. dimenions)

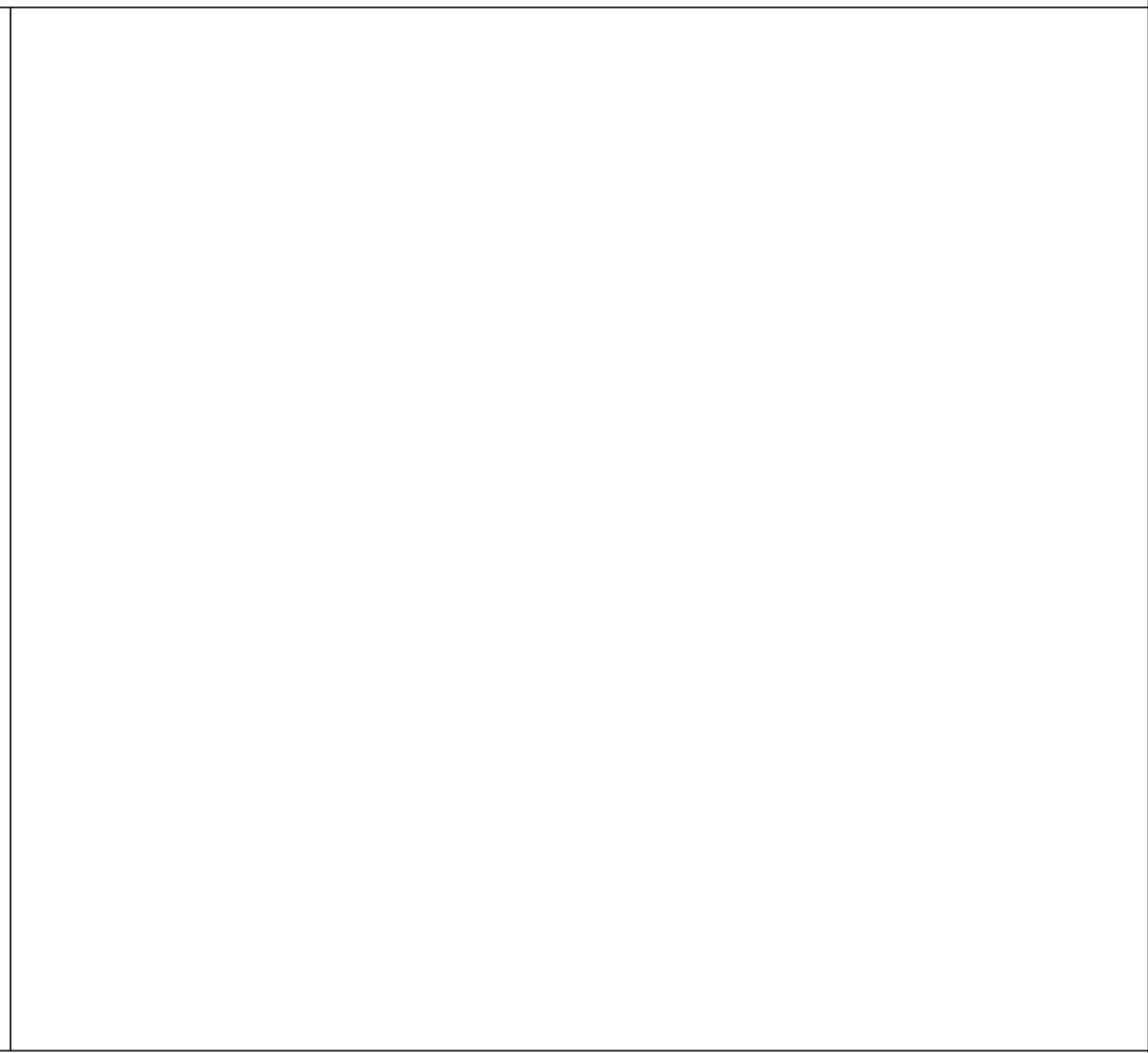
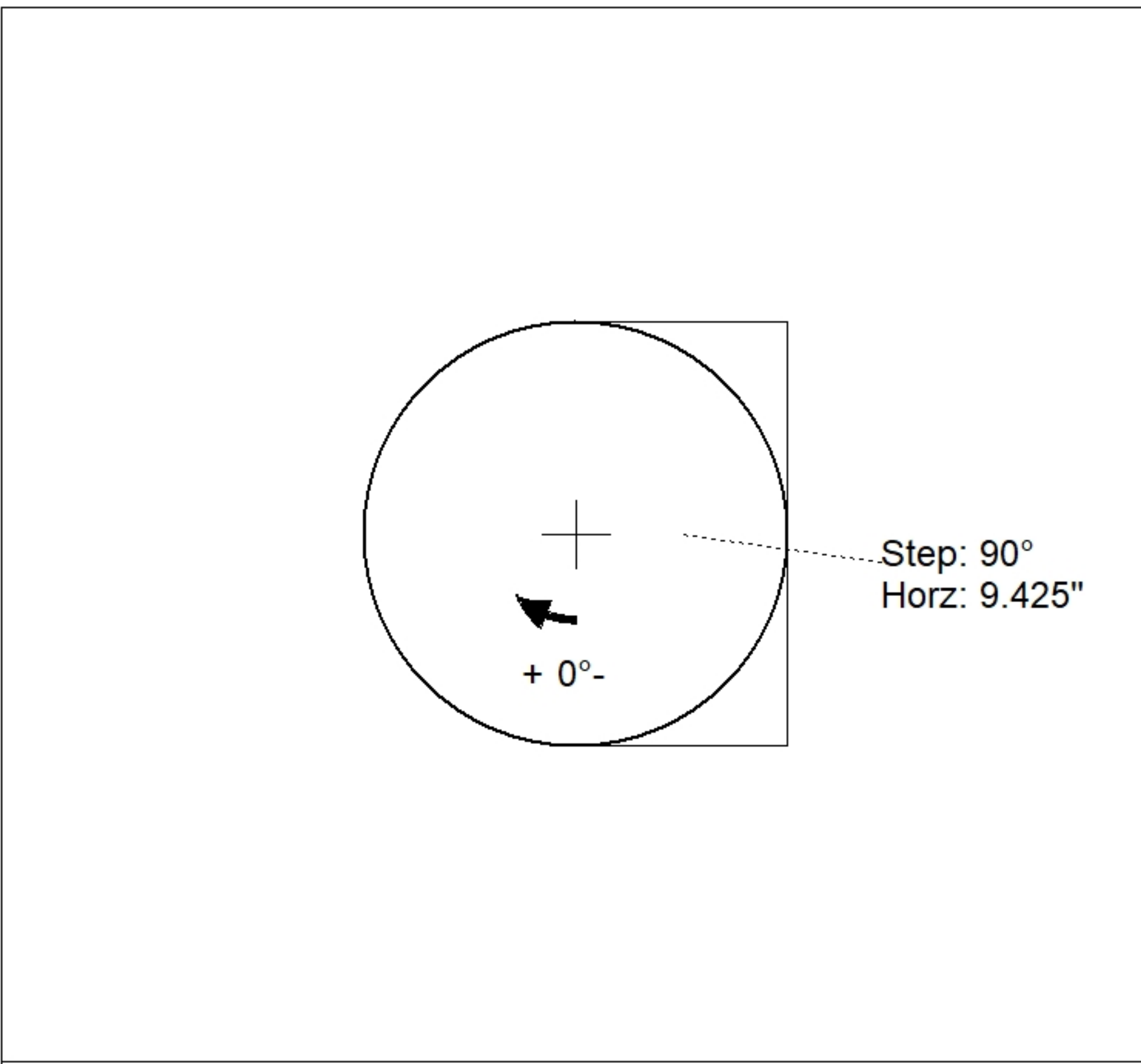
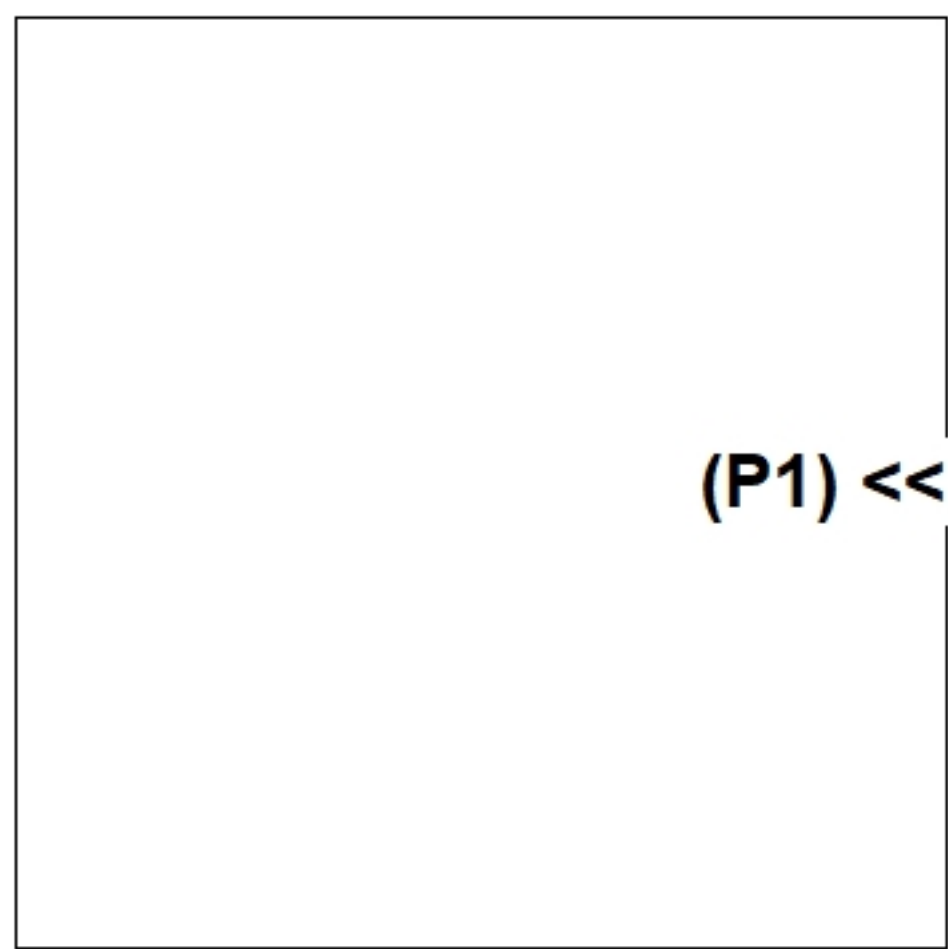

INSIDE WALL DIMENSIONS

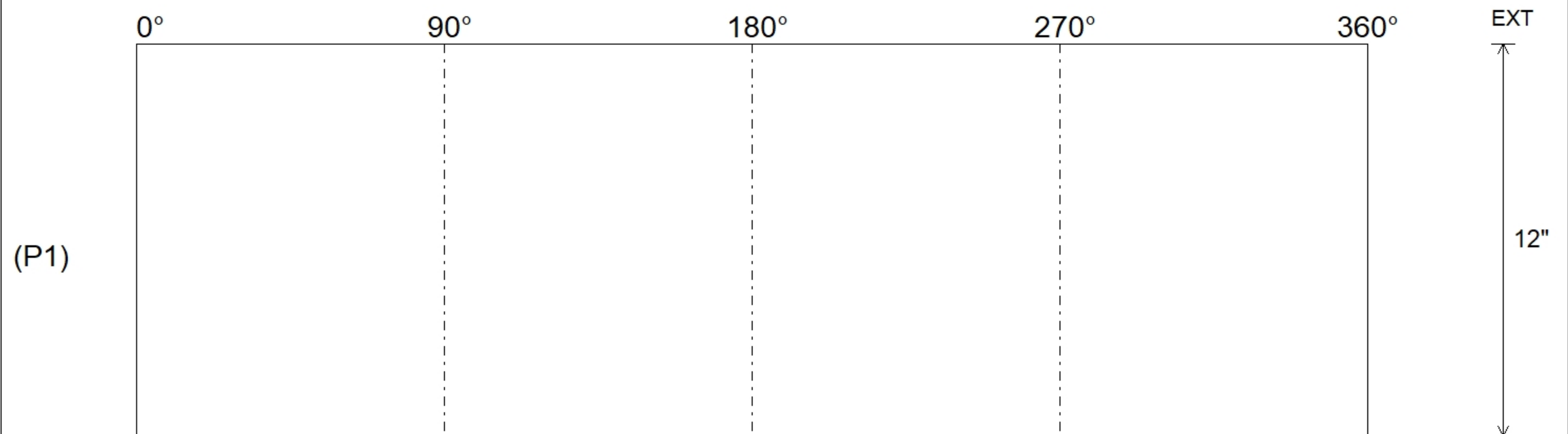

Coating (Int):	Seam Up: Flat	Wall Thickness: 0"	Height (Int): 12"	Weight (Net): 3037 lb
Coating (Ext):	Seam Dn: Flat	Floor Height: 0"	Height (Ext): 12"	Volume (Net): 0cu.yd