

Job Name: 25-2861 Spencer Co Bus Garage
 Job Location: Taylorsville, Ky
 Contractor: Louisville Paving and Construction

Plant: Beaver Dam

Tech: C.Russ

10/22/2025 10:49:20 AM

PC: J.Jarvis



Structure ID: CI-1C

P1 BX2436-08BVF

BOX BASE 8inW, 8inF, Variable Ht F/n

- P2) 24" x 36" - CASTING HEIGHT - 6"
- P1) 24" x 36" - BOX BASE 8inW, 8inF, Variable Ht F/n - 30"
- 1) CASTING - HOE 525 LV SET (F/G/H)
- 1) 24" x 36" - SGL 1"x14.5' Butyl
- 1) Hole - 14
- 1) Hole - 6

0 lb
 4304 lb
 442 lb
 0 lb
 0 lb
 0 lb
 Structure Total: 4746 lb

- Structure Notes:**
1. PER ASTM C913 SPECIFICATIONS.
 2. CONCRETE = 4,000 PSI AT 28 DAYS.
 3. NO INVERT CHANNEL.
 4. HOE 525 PROVIDED BY ICAST.
 5. REINFORCING PER ASTM A615 (GRADE 60).
 - WALLS (As .12) #5 BARS AT 12" C.C.E.W.
 - FLOOR (As .12) #5 BARS AT 12" C.C.E.W.

Rim: 700.2' Rim to Invert: 3' Slack: 0" Sump: 0" Step Position: 270°

Position	Elev	Angle	Ext. (cw)	Pipe	Pipe OD	Connector	Hole	Horz Size	Up ()	Offset
Invert 1	697.2'	220°	27.457"	10" HDPE	11.4"	Hole 14	14"	18.276"	-0.7"	-11"
Invert 2	698.5'	270°	26"	4" HDPE (perf pipe)	4.8"	Hole 6	6"	6"	15.2"	0"
Invert 3										
Invert 4										
Invert 5										
Invert 6										
Invert 7										
Invert 8										

RIGHT-SIDE UP VIEW (int. dimensions)

UPSIDE-DOWN VIEW (int. dimensions)

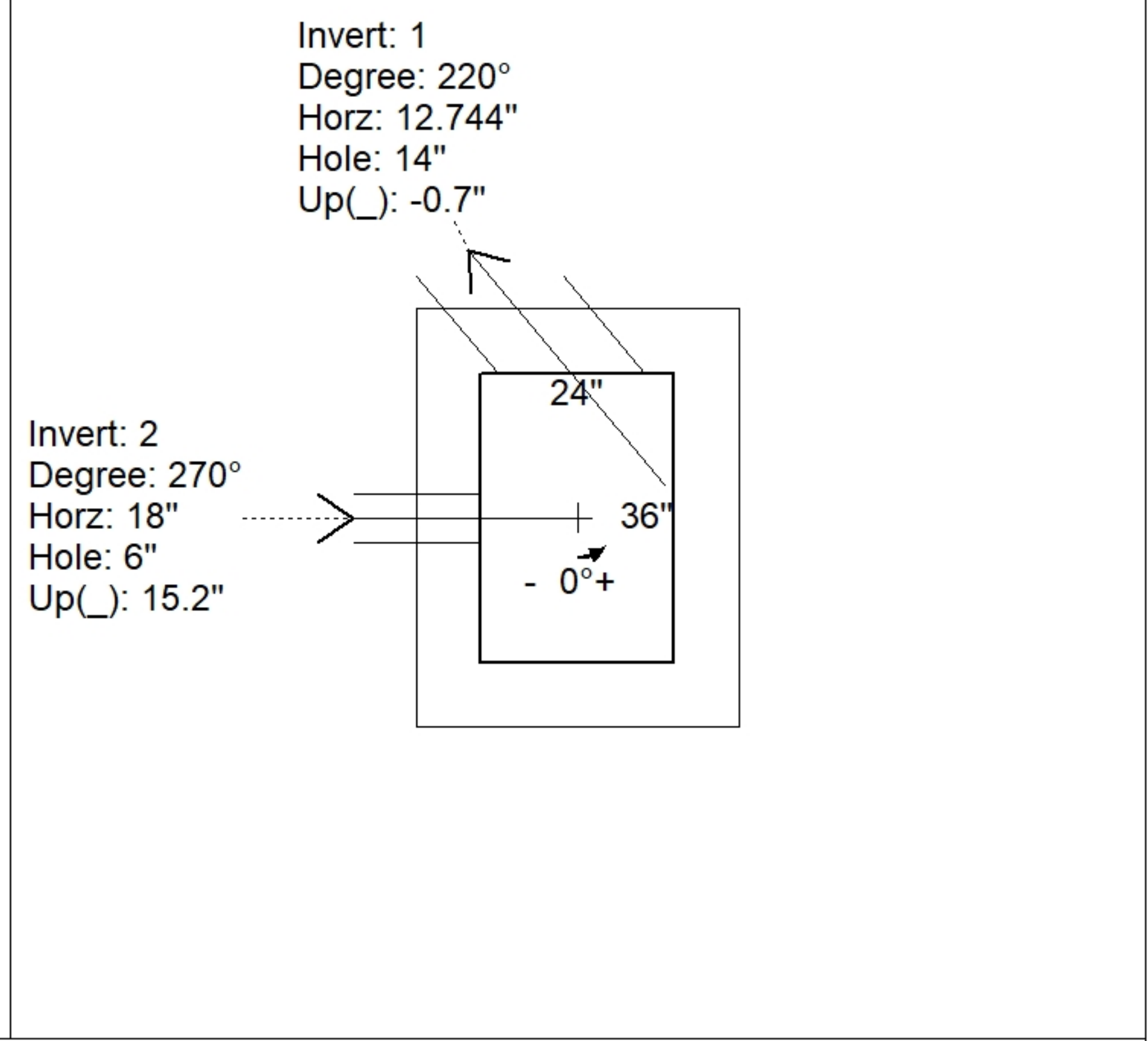
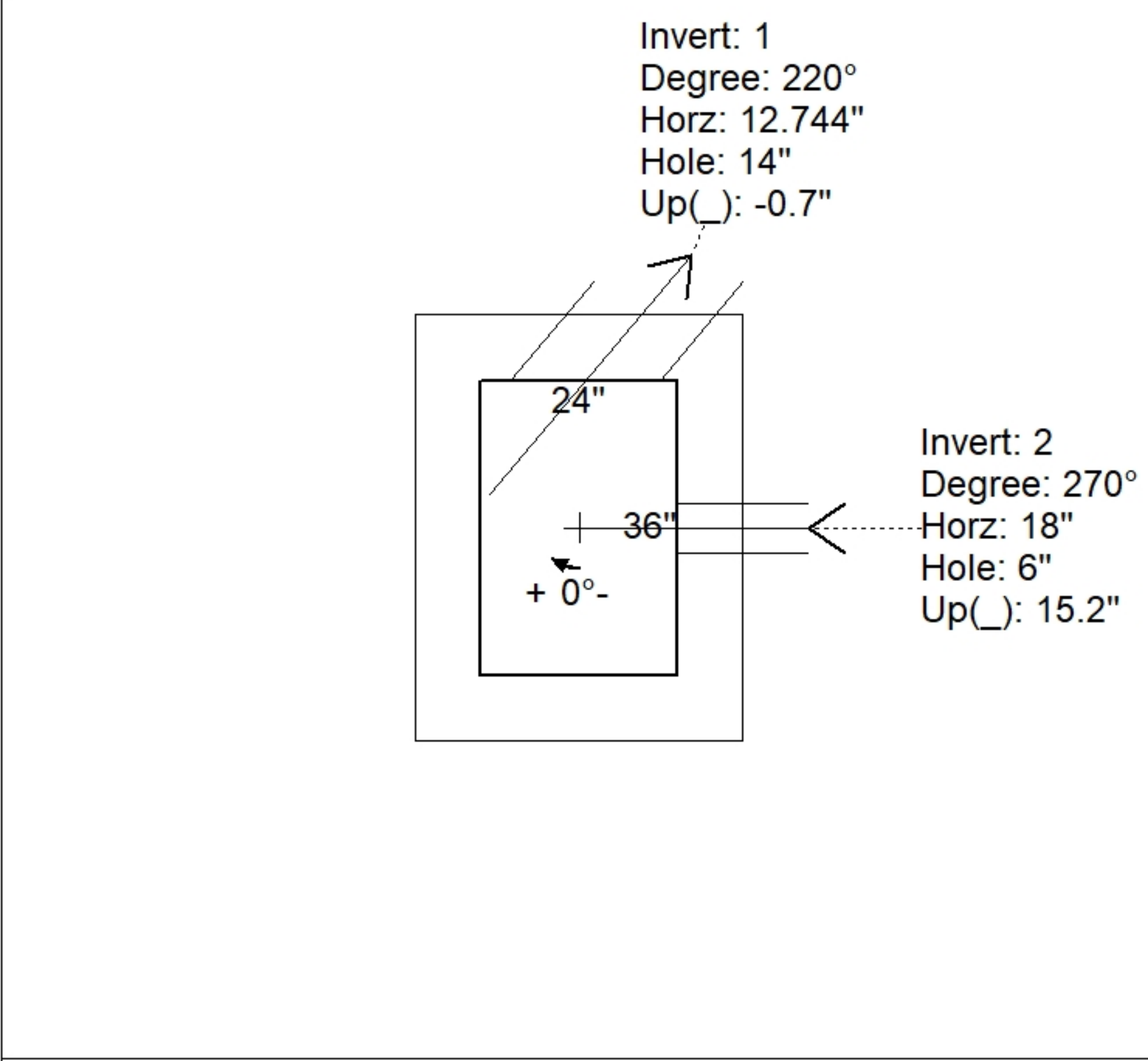
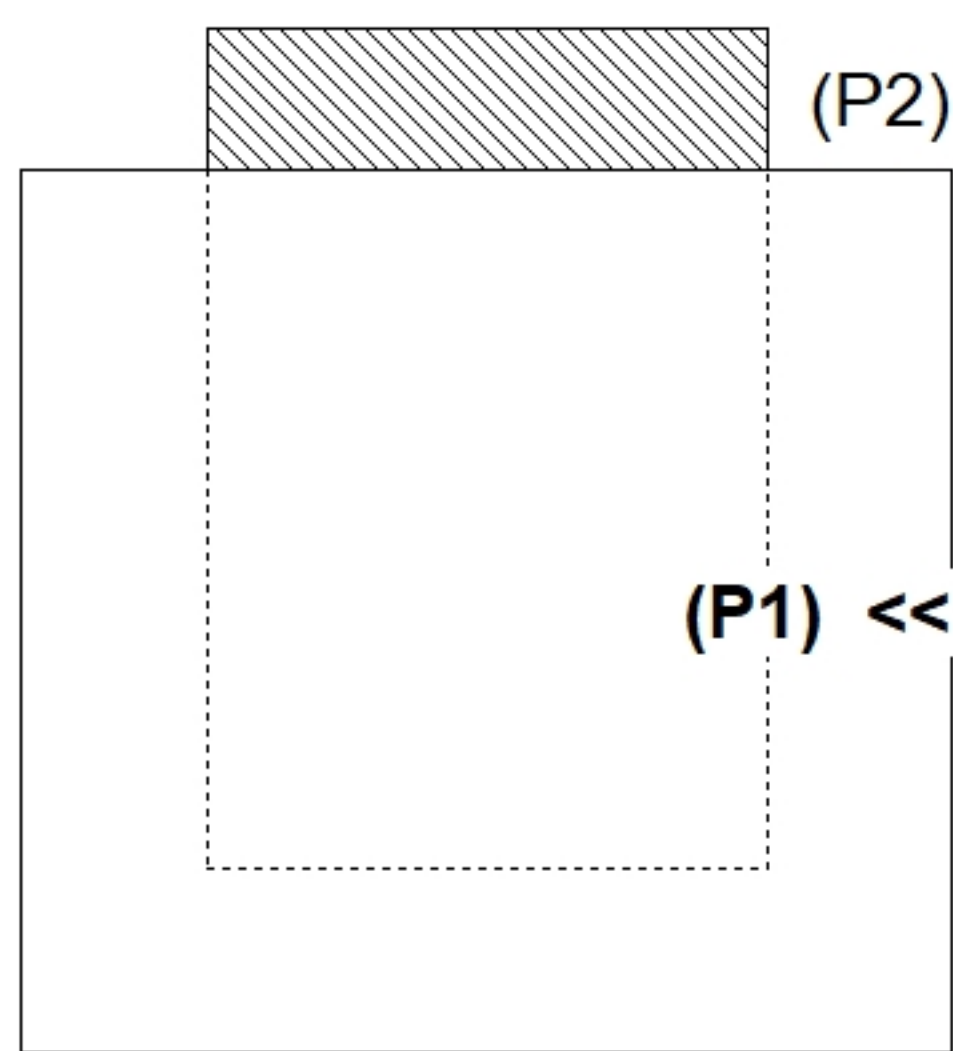

INSIDE WALL DIMENSIONS

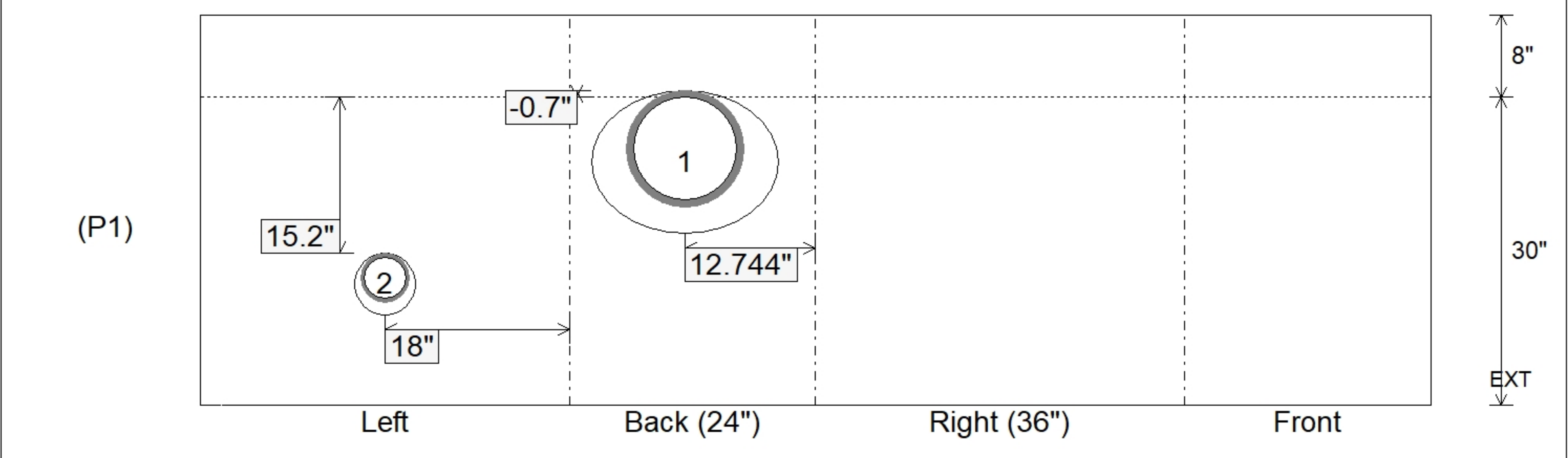

Coating (Int): Coating (Ext):	Seam Up: Flat Seam Dn: n/a	Wall Thickness: 8" Floor Height: 8"	Height (Int): 30" Height (Ext): 38"	Weight (Net): 4304 lb Volume (Net): 1.1cu.yd
----------------------------------	-------------------------------	----------------------------------------	----------------------------------------	-------------------------------------------------