

Job Name: 25-2860 Grace Park
 Job Location: Nashville, TN
 Contractor: Elite Building Group Inc.

Plant: Beaver Dam
 10/14/2025 3:22:03 PM

Tech: C.Russ
 PC: A.Chambers



Structure ID: 1A

P2 MH048LD12X-32ECC

MH FLAT TOP w/32" Hole ECC w/Xypex F/G

- P3) 32" - CASTING HEIGHT - 7"
- P2) 48" - MH FLAT TOP w/32" Hole ECC w/Xypex F/G - 12"
- P1) 48" - MH BASE Custom Ht, w/XYPEX T/n - 27"
- 1) 48" - MH INVERT CHANNEL w/XYPEX - FULL HEIGHT
- 1) JOINT WRAP - 0.065"x6"x50' CONSEAL CS212
- 1) JOINT WRAP PRIMER - CONSEAL CS-75 (1 gal.)
- 1) ADMIXTURE CONBLOCK CDA RED
- 1) 48" - DBL 1"x14.5' Butyl (2x)
- 1) PSX - 12-08 NYLO

0 lb
 1851 lb
 3169 lb
 1440 lb
 0 lb
 0 lb
 0 lb
 0 lb
 0 lb
 8 lb

Structure Total: 6467 lb

Structure Notes:
 1. PER ASTM C913 SPECIFICATIONS.
 2. CONCRETE = 4,000 PSI AT 28 DAYS.
 3. NO INVERT CHANNEL.
 4. CASTING BY OTHERS

REINFORCING PER ASTM A615 (GRADE 60).
 - WALLS (As .31) #5 BARS AT 12" C.C.E.W.
 - FLOOR (As .31) #5 BARS AT 12" C.C.E.W.

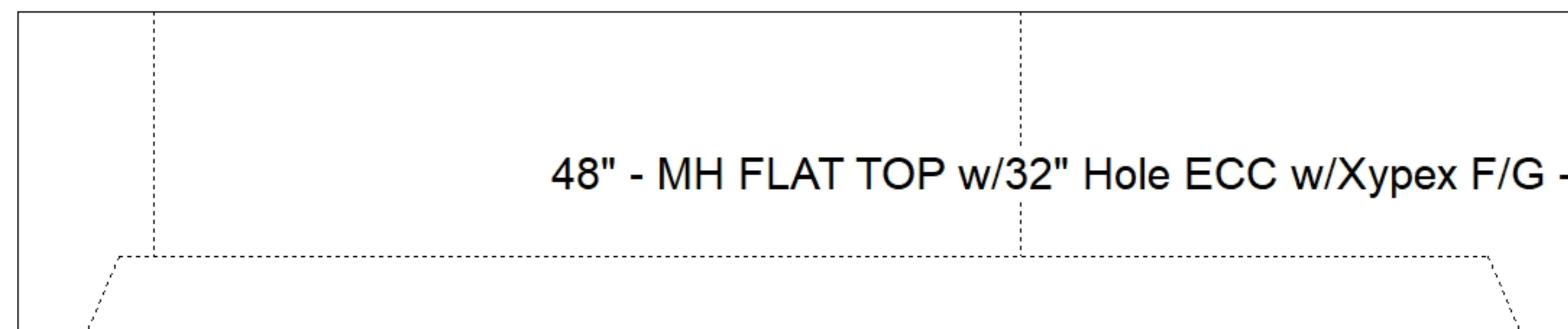
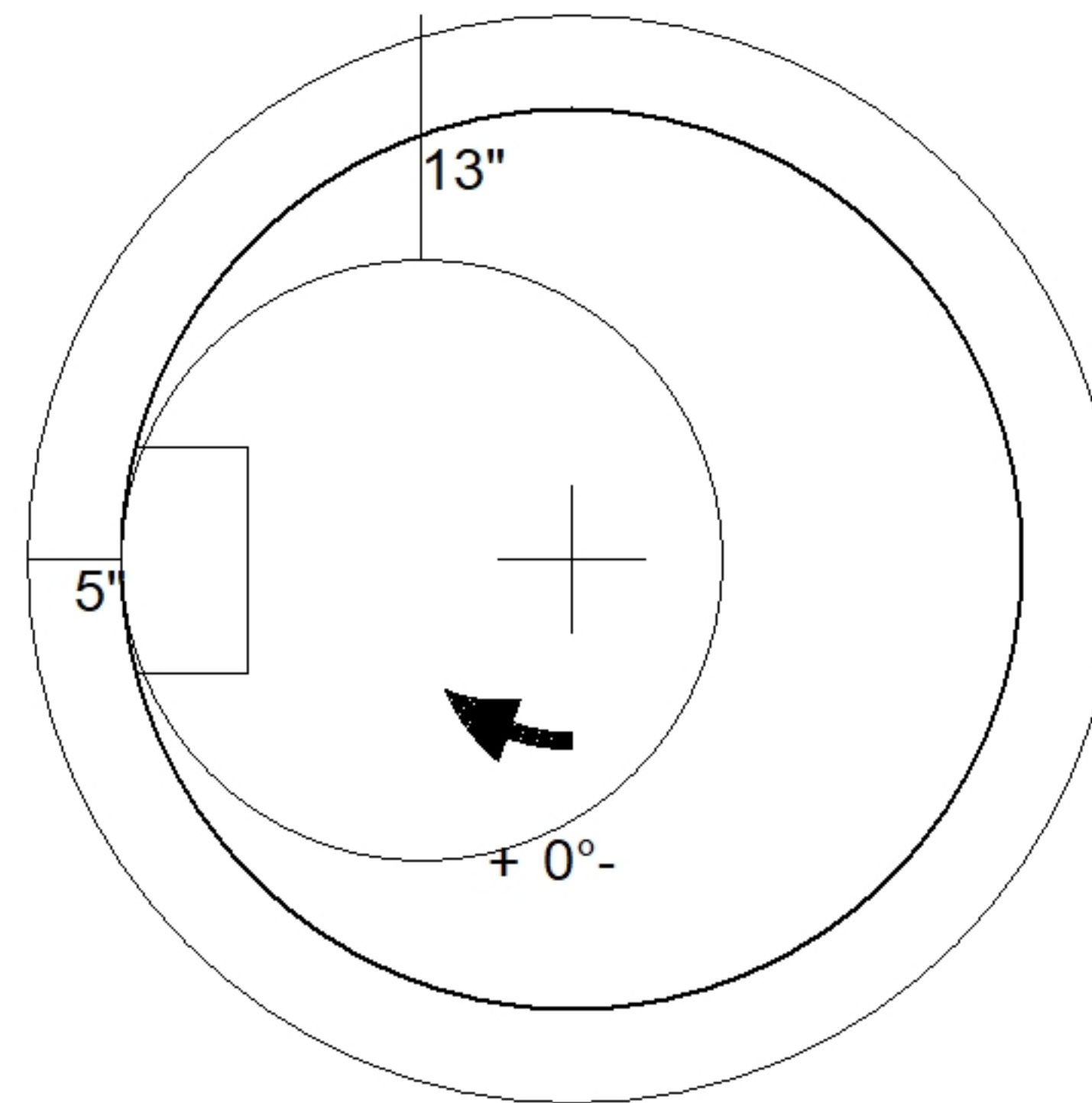

Coating (Int):	Seam Up: Flat	Wall Thickness: 5"	Height (Ext): 12"	Weight (Net): 1851 lb
Coating (Ext):	Seam Dn: Groove			Volume (Net): 0.47cu.yd