



Date: 9/18/25

Core & Main LP (Louisville)
13106 Middletown Ind Blvd.
Louisville, KY 40223

Project #: 25-3292
Project: Arbor View Sec. 2

We are sending you attached:

- Submittal details-file copy only
- Submittal details for approval

To ensure quality service, and to aid you with your desired work schedule please return this submittal package with any comments/corrections in a timely fashion so that we can begin the production and management of your project.

Submittal details for production prior to engineer's approval

- Request of production prior to engineer's approval requires contractor/customer to accept purchase and delivery without exception.
- Your approval verification below must be returned to Infrastructure Precast, Inc. before production can be scheduled (see below)

I, _____, understand that I am instructing Infrastructure Precast, Inc. to proceed with production without the Engineer's submittal approval; therefore, I agree that all financial responsibility rests with me regardless of any changes made by the Engineer that may occur after the fact.

Signature: _____ Date: _____

Detailed submittal drawings for non-standard structures

For all non-standard items a detailed submittal drawing is created and must be reviewed by the contractor and the Project Engineer to ensure accuracy before Infrastructure Precast, Inc. can produce any non-standard structure.

COPIES	DATE	DESCRIPTION
1 via email	9/18/24	Submittal drawings for review and approval.

The above items are transmitted for your review and approval. Please contact your project manager with any questions.

Project Manager: Jay Jarvis
Phone – 259-7670
Email – jjarvis@icastinc.com



RFI

(Request for Information)

- 1.) SSMH's F1 & G1: Verify the required invert elevations of the 2 – 6" PVC service lines. Assumed @ 0.2' of fall to outlet elevation.
- 2.) All CBI's: These submittals reflect the use of JR HOE-525 Vane F/G/H assemblies for each CBI. Plan Views appear to show a KYTC Style Throated Curb Inlet layout maybe required. Please Verify.
- 3.) All Yard Drains: These submittals reflect the use of JR HOE-518 F/G's. Please verify.
- 4.) SSMH-F2: 8" PVC inlet elevation raised to 908.93 to achieve the plan noted & VMU required minimum 0.1' of fall across the manhole base.

1. 0.2' OF FALL ACROSS THE MANHOLE IS ACCEPTABLE.
2. MODEL IS SATISFACTORY WITH JR HOE 525 INLETS. APPROVED AS AN ALTERNATE.
3. YARD INLETS ARE MODELED AS 24 X 24 SQUARE GRATES. JR HOE MODEL WILL BE SUFFICIENT. APPROVED
4. APPROVED

ENGINEER COMMENTS:

1. PER DOW COMMENT THERE WILL BE A MANHOLE ADDED AT THE TIE IN OF SANITARY LINE G. THIS EXISTING LINE WOULD HAVE TO BE SPOT DUG AND VERIFIED TO DETERMINE CORE HOLED LOCATIONS.
2. CONFIRM CBI-A-6 IS A CURB BOX INLET AS SPECIFIED, STRUCTURE TYPE IS CALLED OUT AS MANHOLE.

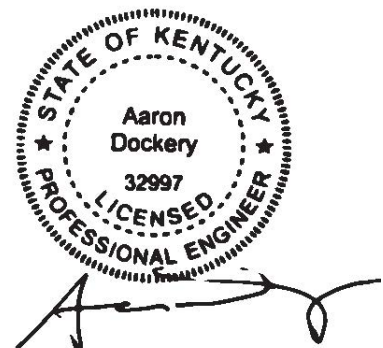



Work Order Submittals (Sanitary)

Job Name: 25-3292 Arbor View Sec. 2
Job Location: Eminence, KY
Contractor: Core & Main LP (Lou)

PC: J.Jarvis
 TECH: C.Russ
 Plant: Beaver Dam



Structure ID: **SSMH F1**
 Spec: Sanitary
 Type: SAN.MH
 Size: 48"

Rim: 916.56'
 Invert: 912.14'
 Rim to Invert: 4.42'

Sump: 2"
 Floor (Top): 911.973'
 Floor Height: 6"

Overall Height: 5.083'
 Slack: 0.04"

Structure Notes:

1. PER ASTM C478 SPECIFICATIONS.
2. CONCRETE = 4,000 PSI AT 28 DAYS.
3. MC-315 "SANITARY" BY ICAST
4. REINFORCING PER ASTM A615 (GRADE 60).
 - CONE (As .12)
 - RISER/WALLS (As .12)
 - FLOOR (As .31) #5 BARS AT 12" C.C.E.W.
5. NO STEPS

STRUCTURE SUMMARY:

- P3) 24" - CASTING HEIGHT - 7" 0 lb
 - P2) 48" - MH FLAT TOP w/ 24" ECC Hole F/G - 12" 1561 lb
 - P1) 48" - MH BASE T/n - 36" 3779 lb
 - 1) 48" - MH INVERT CHANNEL - FULL HEIGHT 1440 lb
 - 1) JOINT WRAP - 0.065"x6"x50' CONSEAL CS212 0 lb
 - 1) JOINT WRAP PRIMER - CONSEAL CS-75 (1 gal.) 0 lb
 - 1) 48" - DBL 1"x14.5' Butyl (2x) 0 lb
 - 1) A-Lok - 0285 1 lb
 - 2) A-Lok - 0210 2 lb
- Structure Total: **6783 lb**

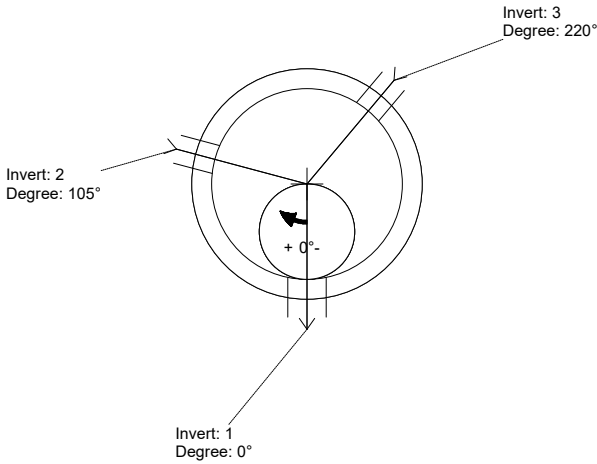

Position	Elev	Angle	Ext. (cw)	Pipe	Hole	Connector	Up (')	Ref
Rim	916.56'							
Reducer								
Invert 1	912.14'	0°	0"	8" PVC SDR35	9.75"	A-Lok 0285	1.125"	P1
Invert 2	912.34'	105°	53.145"	6" PVC SDR35	7.25"	A-Lok 0210	3.775"	P1
Invert 3	912.34'	220°	111.352"	6" PVC SDR35	7.25"	A-Lok 0210	3.775"	P1
Invert 4								
Invert 5								
Invert 6								
Invert 7								
Invert 8								

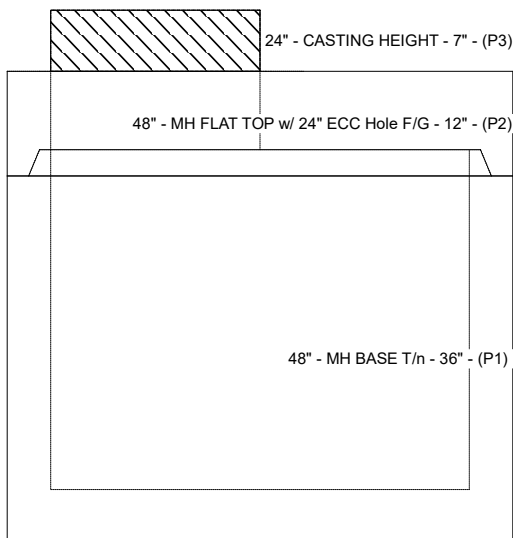

Default - Interior Dimensions

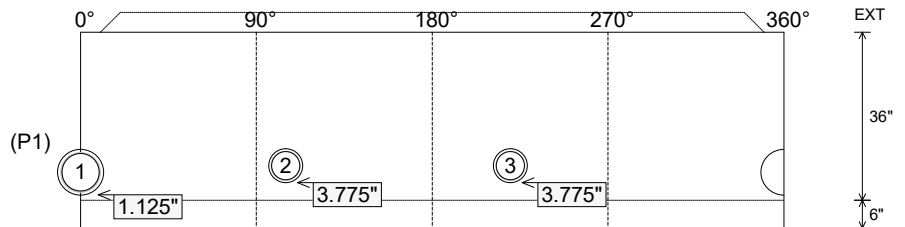

Submittal Drawing
 9/18/2025 6:45:29 AM

SUBMITTAL
 APPROVED BY:

Job Name: 25-3292 Arbor View Sec. 2
Job Location: Eminence, KY
Contractor: Core & Main LP (Lou)

PC: J.Jarvis
 TECH: C.Russ
 Plant: Beaver Dam



Structure ID: **SSMH F2**

Spec: Sanitary
 Type: SAN.MH
 Size: 48"

Rim: 913.9'
 Invert: 908.83'
 Rim to Invert: 5.07'

Sump: 2"
 Floor (Top): 908.663'
 Floor Height: 6"

Overall Height: 5.583'
 Slack: 1.84"

Structure Notes:

1. PER ASTM C478 SPECIFICATIONS.
2. CONCRETE = 4,000 PSI AT 28 DAYS.
3. MC-315 "SANITARY" BY ICAST
4. REINFORCING PER ASTM A615 (GRADE 60).
 - CONE (As .12)
 - RISER/WALLS (As .12)
 - FLOOR (As .31) #5 BARS AT 12" C.C.E.W.
5. NO STEPS

RFI: 8" PVC INLET ELEVATION RAISED TO 908.93 TO ACHIEVE THE PLAN NOTED & VMU REQUIRED MINIMUM 0.1' OF FALL ACROSS THE MANHOLE BASE SECTION.

STRUCTURE SUMMARY:

P3) 24" - CASTING HEIGHT - 7"	0 lb
P2) 48" - ECC CONE w/ 24" HOLE F/G - 30"	2050 lb
P1) 48" - MH BASE T/n - 24"	2944 lb
1) 48" - MH INVERT CHANNEL - FULL HEIGHT	1440 lb
1) JOINT WRAP - 0.065"x6"x50' CONSEAL CS212	0 lb
1) JOINT WRAP PRIMER - CONSEAL CS-75 (1 gal.)	0 lb
1) 48" - DBL 1"x14.5' Butyl (2x)	0 lb
2) A-Lok - 0285	2 lb
Structure Total:	6436 lb

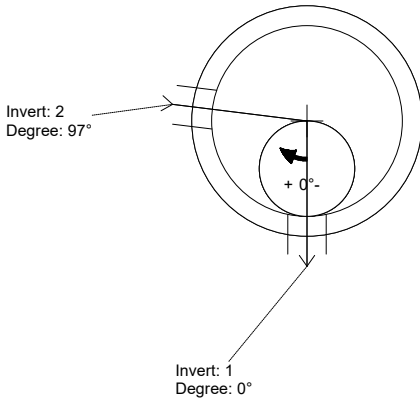

Position	Elev	Angle	Ext. (cw)	Pipe	Hole	Connector	Up ()	Ref
Rim	913.9'							
Reducer								
Invert 1	908.83'	0°	0"	8" PVC SDR35	9.75"	A-Lok 0285	1.125"	P1
Invert 2	908.86'	97°	49.096"	8" PVC SDR35	9.75"	A-Lok 0285	1.485"	P1
Invert 3								
Invert 4								
Invert 5								
Invert 6								
Invert 7								
Invert 8								

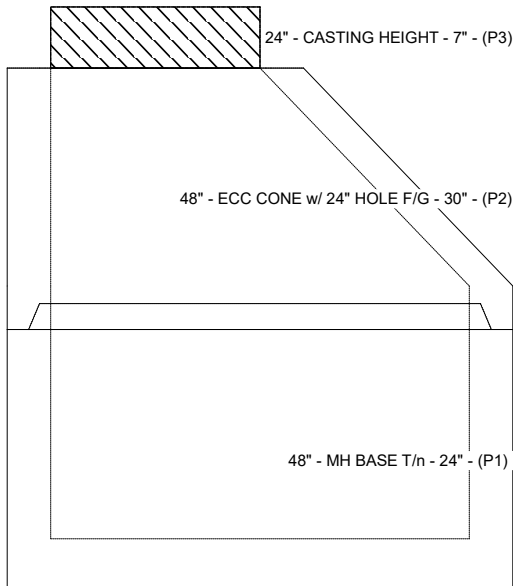

Default - Interior Dimensions

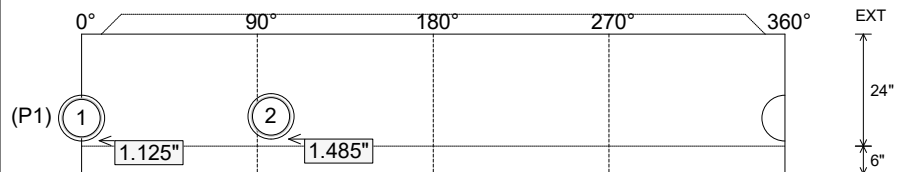

Submittal Drawing
 9/18/2025 6:45:30 AM

SUBMITTAL
 APPROVED BY:

Job Name: 25-3292 Arbor View Sec. 2
Job Location: Eminence, KY
Contractor: Core & Main LP (Lou)

PC: J.Jarvis
 TECH: C.Russ
 Plant: Beaver Dam



Structure ID: **SSMH G1**

Spec: Sanitary
 Type: SAN.MH
 Size: 48"

Rim: 916.16'
 Invert: 911.44'
 Rim to Invert: 4.72'

Sump: 2"
 Floor (Top): 911.273'
 Floor Height: 6"

Overall Height: 5.333'
 Slack: 0.64"

Structure Notes:

1. PER ASTM C478 SPECIFICATIONS.
2. CONCRETE = 4,000 PSI AT 28 DAYS.
3. MC-315 "SANITARY" BY ICAST
4. REINFORCING PER ASTM A615 (GRADE 60).
 - CONE (As .12)
 - RISER/WALLS (As .12)
 - FLOOR (As .31) #5 BARS AT 12" C.C.E.W.
5. NO STEPS

STRUCTURE SUMMARY:

P4) 24" - CASTING HEIGHT - 7"	0 lb
P3) 24" - GRADE RING F/F - 3"	202 lb
P2) 48" - MH FLAT TOP w/ 24" ECC Hole F/G - 12"	1561 lb
P1) 48" - MH BASE T/n - 36"	3779 lb
1) 48" - MH INVERT CHANNEL - FULL HEIGHT	1440 lb
1) JOINT WRAP - 0.065"x6"x50' CONSEAL CS212	0 lb
1) JOINT WRAP PRIMER - CONSEAL CS-75 (1 gal.)	0 lb
1) 48" - DBL 1"x14.5' Butyl (2x)	0 lb
1) A-Lok - 0285	1 lb
2) A-Lok - 0210	2 lb
Structure Total:	6985 lb

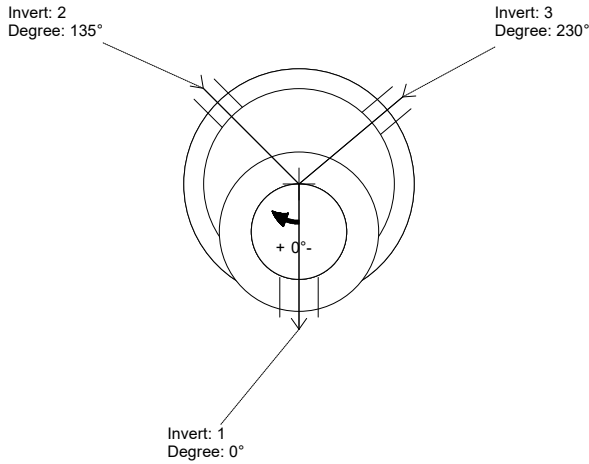

Position	Elev	Angle	Ext. (cw)	Pipe	Hole	Connector	Up (")	Ref
Rim	916.16'							
Reducer								
Invert 1	911.44'	0°	0"	8" PVC SDR35	9.75"	A-Lok 0285	1.125"	P1
Invert 2	911.64'	135°	68.33"	6" PVC SDR35	7.25"	A-Lok 0210	3.775"	P1
Invert 3	911.64'	230°	116.413"	6" PVC SDR35	7.25"	A-Lok 0210	3.775"	P1
Invert 4								
Invert 5								
Invert 6								
Invert 7								
Invert 8								

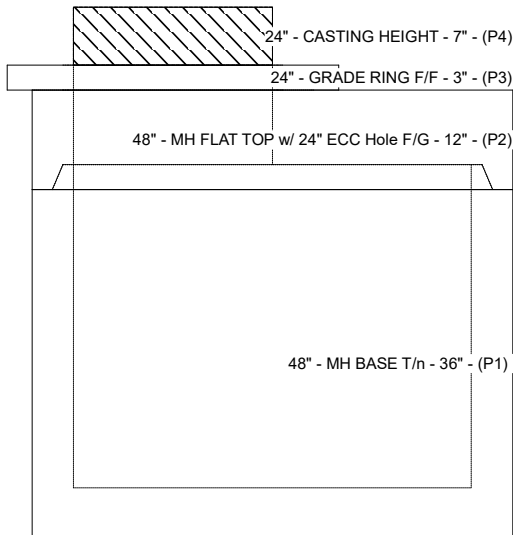

Default - Interior Dimensions

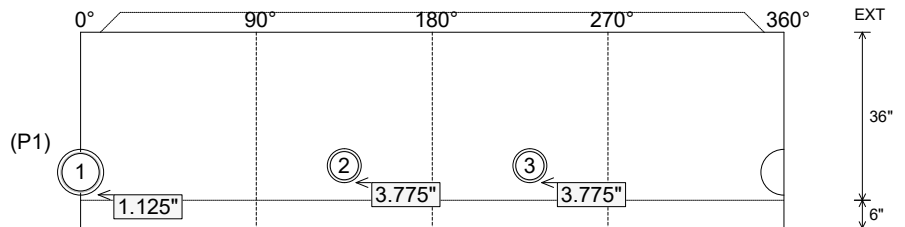

Submittal Drawing
 9/18/2025 6:45:30 AM

SUBMITTAL
 APPROVED BY:

Job Name: 25-3292 Arbor View Sec. 2
Job Location: Eminence, KY
Contractor: Core & Main LP (Lou)

PC: J.Jarvis
 TECH: C.Russ
 Plant: Beaver Dam



Structure ID: **SSMH G2**

Spec: Sanitary
 Type: SAN.MH
 Size: 48"

Rim: 911.79'
 Invert: 906.65'
 Rim to Invert: 5.14'

Sump: 2"
 Floor (Top): 906.483'
 Floor Height: 6"

Overall Height: 5.583'
 Slack: 2.68"

Structure Notes:

1. PER ASTM C478 SPECIFICATIONS.
2. CONCRETE = 4,000 PSI AT 28 DAYS.
3. MC-315 "SANITARY" BY ICAST
4. REINFORCING PER ASTM A615 (GRADE 60).
 - CONE (As .12)
 - RISER/WALLS (As .12)
 - FLOOR (As .31) #5 BARS AT 12" C.C.E.W.
5. NO STEPS

STRUCTURE SUMMARY:

P3) 24" - CASTING HEIGHT - 7"	0 lb
P2) 48" - ECC CONE w/ 24" HOLE F/G - 30"	2050 lb
P1) 48" - MH BASE T/n - 24"	2944 lb
1) 48" - MH INVERT CHANNEL - FULL HEIGHT	1440 lb
1) JOINT WRAP - 0.065"x6"x50' CONSEAL CS212	0 lb
1) JOINT WRAP PRIMER - CONSEAL CS-75 (1 gal.)	0 lb
1) 48" - DBL 1"x14.5' Butyl (2x)	0 lb
2) A-Lok - 0285	2 lb
Structure Total:	6436 lb

Invert: 2
 Degree: 138°

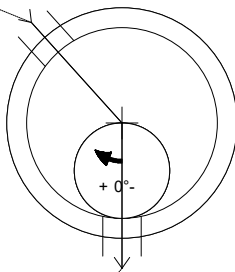

Invert: 1
 Degree: 0°

Position	Elev	Angle	Ext. (cw)	Pipe	Hole	Connector	Up (")	Ref
Rim	911.79'							
Reducer								
Invert 1	906.65'	0°	0"	8" PVC SDR35	9.75"	A-Lok 0285	1.125"	P1
Invert 2	906.75'	138°	69.848"	8" PVC SDR35	9.75"	A-Lok 0285	2.325"	P1
Invert 3								
Invert 4								
Invert 5								
Invert 6								
Invert 7								
Invert 8								

Default - Interior Dimensions

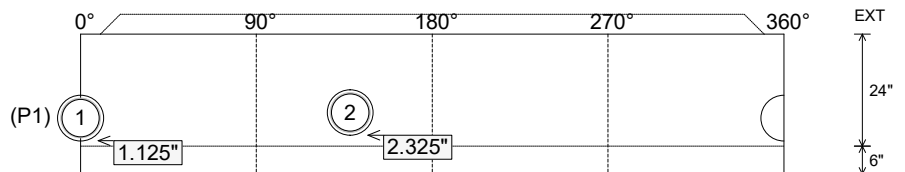
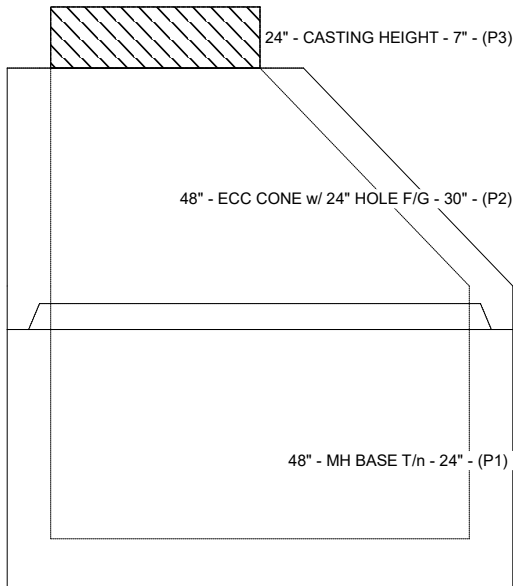

Submittal Drawing
 9/18/2025 6:45:31 AM

SUBMITTAL
 APPROVED BY:

Job Name: 25-3292 Arbor View Sec. 2
Job Location: Eminence, KY
Contractor: Core & Main LP (Lou)

PC: J.Jarvis
 TECH: C.Russ
 Plant: Beaver Dam



Structure ID: **SSMH G3**

Spec: Sanitary
 Type: SAN.MH
 Size: 48"

Rim: 905.27'
 Invert: 900.33'
 Rim to Invert: 4.94'

Sump: 2"
 Floor (Top): 900.163'
 Floor Height: 6"

Overall Height: 5.583'
 Slack: 0.28"

Structure Notes:

1. PER ASTM C478 SPECIFICATIONS.
2. CONCRETE = 4,000 PSI AT 28 DAYS.
3. MC-315 "SANITARY" BY ICAST
4. REINFORCING PER ASTM A615 (GRADE 60).
 - CONE (As .12)
 - RISER/WALLS (As .12)
 - FLOOR (As .31) #5 BARS AT 12" C.C.E.W.
5. NO STEPS

STRUCTURE SUMMARY:

P3) 24" - CASTING HEIGHT - 7"	0 lb
P2) 48" - MH FLAT TOP w/ 24" ECC Hole F/G - 12"	1561 lb
P1) 48" - MH BASE T/n - 42"	4201 lb
1) 48" - MH INVERT CHANNEL - FULL HEIGHT	1440 lb
1) JOINT WRAP - 0.065"x6"x50' CONSEAL CS212	0 lb
1) JOINT WRAP PRIMER - CONSEAL CS-75 (1 gal.)	0 lb
1) 48" - DBL 1"x14.5' Butyl (2x)	0 lb
2) A-Lok - 0285	2 lb
Structure Total:	7204 lb

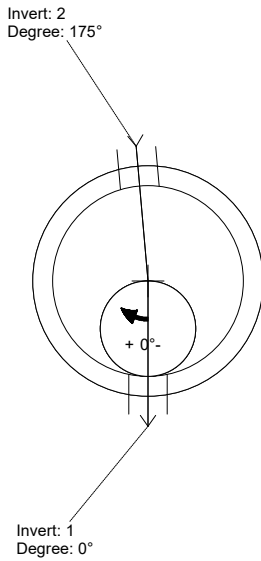

Position	Elev	Angle	Ext. (cw)	Pipe	Hole	Connector	Up (")	Ref
Rim	905.27'							
Reducer								
Invert 1	900.33'	0°	0"	8" PVC SDR35	9.75"	A-Lok 0285	1.125"	P1
Invert 2	900.43'	175°	88.575"	8" PVC SDR35	9.75"	A-Lok 0285	2.325"	P1
Invert 3								
Invert 4								
Invert 5								
Invert 6								
Invert 7								
Invert 8								

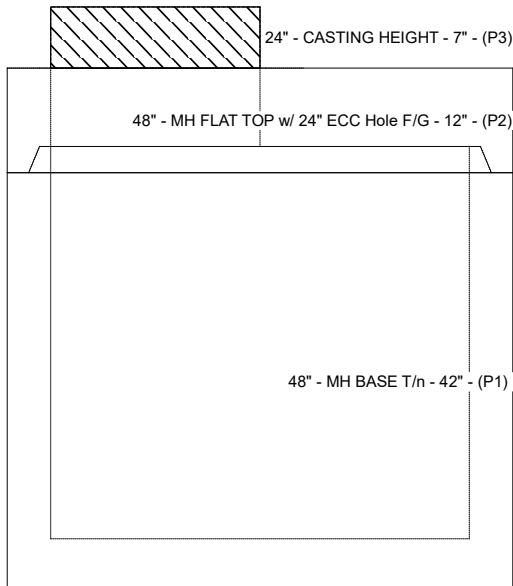

Default - Interior Dimensions

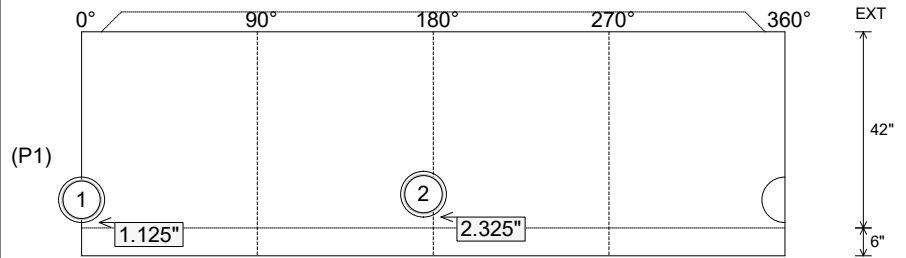

Submittal Drawing
 9/18/2025 6:45:32 AM

SUBMITTAL
 APPROVED BY:

Job Name: 25-3292 Arbor View Sec. 2
Job Location: Eminence, KY
Contractor: Core & Main LP (Lou)

PC: J.Jarvis
 TECH: C.Russ
 Plant: Beaver Dam



Structure ID: **SSMH G4**

Spec: Sanitary
 Type: SAN.MH
 Size: 48"

Rim: 899.06'
 Invert: 890.87'
 Rim to Invert: 8.19'

Sump: 2"
 Floor (Top): 890.703'
 Floor Height: 6"

Overall Height: 8.833'
 Slack: 0.28"

Structure Notes:

- PER ASTM C478 SPECIFICATIONS.
- CONCRETE = 4,000 PSI AT 28 DAYS.
- MC-315 "SANITARY" BY ICAST
- REINFORCING PER ASTM A615 (GRADE 60).
 - CONE (As .12)
 - RISER/WALLS (As .12)
 - FLOOR (As .31) #5 BARS AT 12" C.C.E.W.
- NO STEPS

STRUCTURE SUMMARY:

- P5) 24" - CASTING HEIGHT - 7" 0 lb
 - P4) 24" - GRADE RING F/F - 3" 202 lb
 - P3) 48" - ECC CONE w/ 24" HOLE F/G - 30" 2050 lb
 - P2) 48" - MH RISER T/G - 36" 2515 lb
 - P1) 48" - MH BASE T/n - 24" 2944 lb
 - 1) 48" - MH INVERT CHANNEL - FULL HEIGHT 1440 lb
 - 1) JOINT WRAP - 0.065"x6"x50' CONSEAL CS212 0 lb
 - 1) JOINT WRAP PRIMER - CONSEAL CS-75 (1 gal.) 0 lb
 - 2) 48" - DBL 1"x14.5' Butyl (2x) 0 lb
 - 2) A-Lok - 0285 2 lb
- Structure Total: 9153 lb

Invert: 2
 Degree: 148°

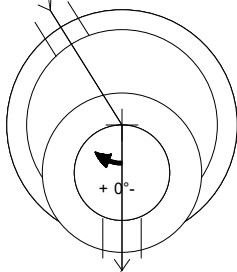

Invert: 1
 Degree: 0°

Position	Elev	Angle	Ext. (cw)	Pipe	Hole	Connector	Up (")	Ref
Rim	899.06'							
Reducer								
Invert 1	890.87'	0°	0"	8" PVC SDR35	9.75"	A-Lok 0285	1.125"	P1
Invert 2	890.97'	148°	74.91"	8" PVC SDR35	9.75"	A-Lok 0285	2.325"	P1
Invert 3								
Invert 4								
Invert 5								
Invert 6								
Invert 7								
Invert 8								

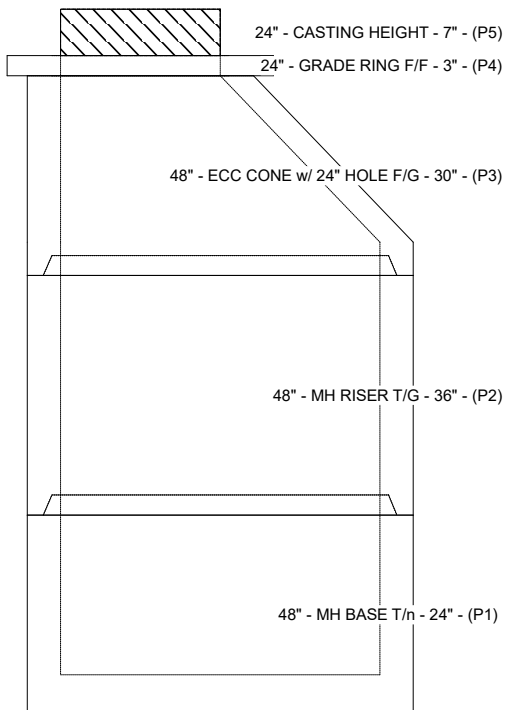

Default - Interior Dimensions

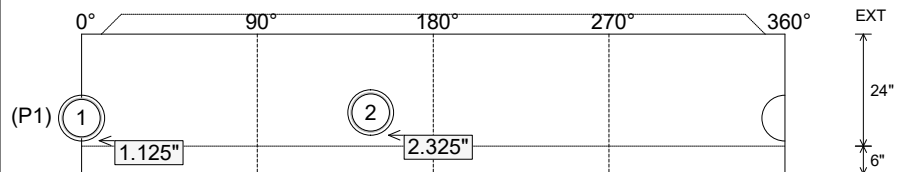

Submittal Drawing
 9/18/2025 6:45:32 AM

SUBMITTAL
 APPROVED BY:



Work Order Submittals (Storm)

Job Name: 25-3292 Arbor View Sec. 2
Job Location: Eminence, KY
Contractor: Core & Main LP (Lou)

PC: J.Jarvis
 TECH: C.Russ
 Plant: Beaver Dam



Structure ID: **CBI-A1**
 Spec: Storm
 Type: BX 8inW, 8inF
 Size: 24" x 36"

Rim: 906.93'
 Invert: 902.62'
 Rim to Invert: 4.31'

Sump: 0"
 Floor (Top): 902.62'
 Floor Height: 8"

Overall Height: 4.917'
 Slack: 0.72"

Structure Notes:

1. PER ASTM C913 SPECIFICATIONS.
2. CONCRETE = 4,000 PSI AT 28 DAYS.
3. NO INVERT CHANNEL.
4. HOE 525 BY ICAST
5. REINFORCING PER ASTM A615 (GRADE 60).
 - WALLS (As .12) #5 BARS AT 12" C.C.E.W.
 - FLOOR (As .12) #5 BARS AT 12" C.C.E.W.

STRUCTURE SUMMARY:

P2) 24" x 36" - CASTING HEIGHT - 6"
 P1) 24" x 36" - BOX BASE 8inW, 8inF, Variable Ht F/n - 45"
 1) 24" x 36" - SGL 1"x14.5' Butyl
 1) Hole - 24

0 lb
 5684 lb
 0 lb
 0 lb

 Structure Total: 5684 lb

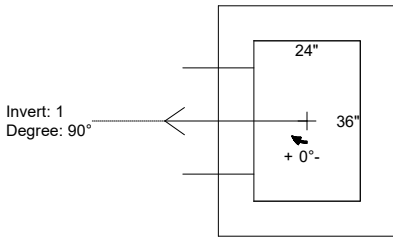

Position	Elev	Angle	Ext. (cw)	Pipe	Hole	Connector	Up (L)	Ref
Rim	906.93'							
Reducer								
Invert 1	902.62'	90°	26"	18" HDPE	24"	Hole 24	-1.6"	P1
Invert 2								
Invert 3								
Invert 4								
Invert 5								
Invert 6								
Invert 7								
Invert 8								

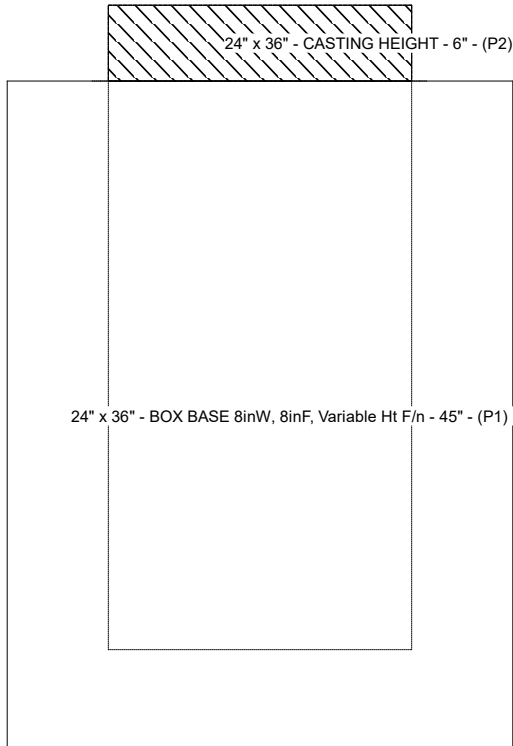

Default - Interior Dimensions

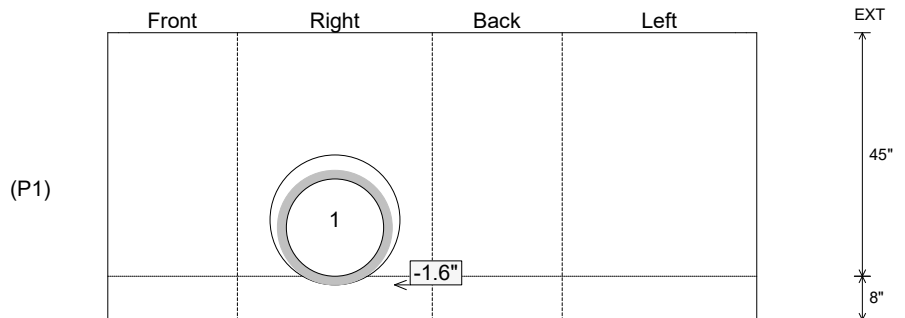

Submittal Drawing
 9/18/2025 6:45:01 AM

SUBMITTAL
 APPROVED BY:

Job Name: 25-3292 Arbor View Sec. 2
Job Location: Eminence, KY
Contractor: Core & Main LP (Lou)

PC: J.Jarvis
 TECH: C.Russ
 Plant: Beaver Dam



Structure ID: **CBI-A2**
 Spec: Storm
 Type: BX 8inW, 8inF
 Size: 24" x 36"

Rim: 906.93'
 Invert: 902.25'
 Rim to Invert: 4.68'

Sump: 0"
 Floor (Top): 902.25'
 Floor Height: 8"

Overall Height: 5.333'
 Slack: 0.16"

Structure Notes:

1. PER ASTM C913 SPECIFICATIONS.
2. CONCRETE = 4,000 PSI AT 28 DAYS.
3. NO INVERT CHANNEL.
4. HOE 525 BY ICAST
5. REINFORCING PER ASTM A615 (GRADE 60).
 - WALLS (As .12) #5 BARS AT 12" C.C.E.W.
 - FLOOR (As .12) #5 BARS AT 12" C.C.E.W.

STRUCTURE SUMMARY:

- P2) 24" x 36" - CASTING HEIGHT - 6"
 P1) 24" x 36" - BOX BASE 8inW, 8inF, Variable Ht F/n - 50"
 1) 24" x 36" - SGL 1"x14.5' Butyl
 2) Hole - 24"

0 lb
 5891 lb
 0 lb
 0 lb

Structure Total: 5891 lb

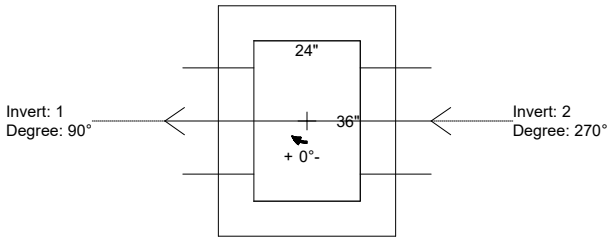

Position	Elev	Angle	Ext. (cw)	Pipe	Hole	Connector	Up (L)	Ref
Rim	906.93'							
Reducer								
Invert 1	902.25'	90°	26"	18" HDPE	24"	Hole 24	-1.6"	P1
Invert 2	902.25'	270°	26"	18" HDPE	24"	Hole 24	-1.6"	P1
Invert 3								
Invert 4								
Invert 5								
Invert 6								
Invert 7								
Invert 8								

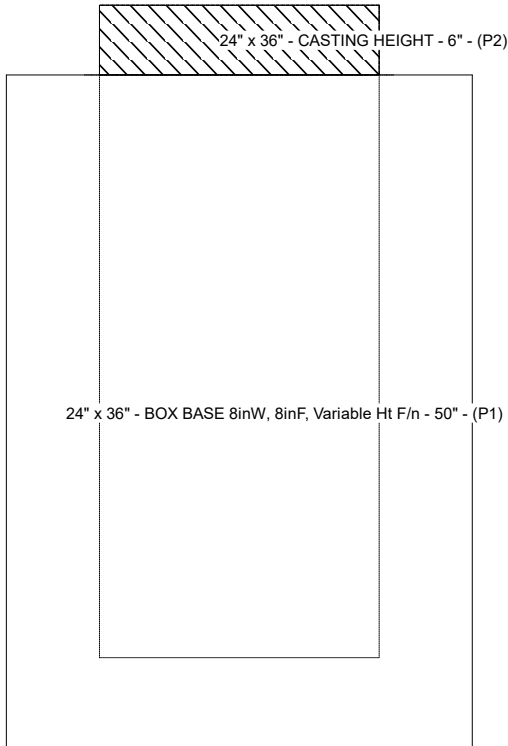

Default - Interior Dimensions

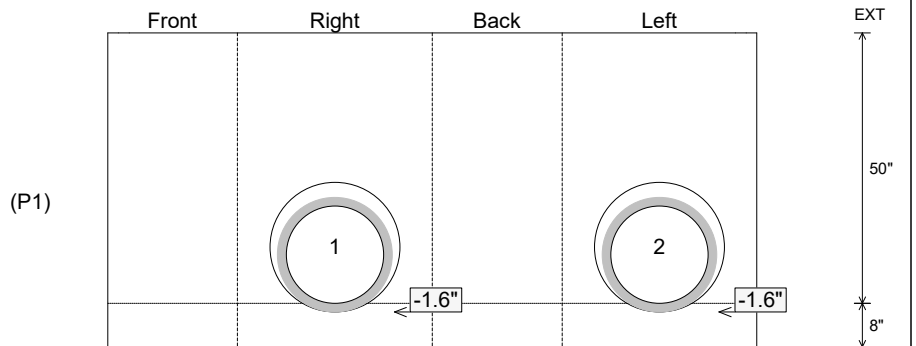

Submittal Drawing
 9/18/2025 6:45:02 AM

SUBMITTAL
 APPROVED BY:

Job Name: 25-3292 Arbor View Sec. 2
Job Location: Eminence, KY
Contractor: Core & Main LP (Lou)

PC: J.Jarvis
 TECH: C.Russ
 Plant: Beaver Dam



Structure ID: YI-A3

Spec: Storm
 Type: STM.MH (Recessed pipe)
 Size: 48"

Rim: 897.3'
 Invert: 890.19'
 Rim to Invert: 7.11'

Sump: 0"
 Floor (Top): 890.19'
 Floor Height: 6"

Overall Height: 7.583'
 Slack: 0.32"

Structure Notes:

1. PER ASTM C478 SPECIFICATIONS.
2. CONCRETE = 4,000 PSI AT 28 DAYS.
3. HOE 518 F/G BY ICAST
4. REINFORCING PER ASTM A615 (GRADE 60).
 - TOP SLAB (As .62) #5 BARS AT 6" C.C.E.W..
 - RISER/WALLS (As .12)
 - FLOOR (As .31) #5 BARS AT 12" C.C.E.W.

STRUCTURE SUMMARY:

P3) 24" x 36" - CASTING HEIGHT - 4"	0 lb
P2) 48" - MH FLAT TOP w/24"x36" Hole F/G - 12"	1300 lb
P1) 48" - MH BASE Custom Ht T/n - 69"	5756 lb
1) 48" - SGL 1"x14.5' Butyl (2x)	0 lb
2) Hole - 24	0 lb
6) MH Step ML-10-TDS-NCR - 10"	0 lb

Structure Total:	7056 lb

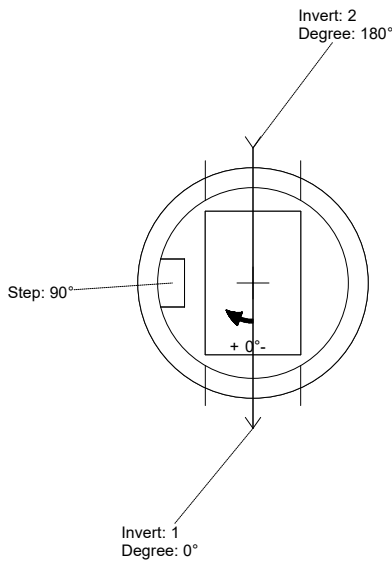

Position	Elev	Angle	Ext. (cw)	Pipe	Hole	Connector	Up (L)	Ref
Rim	897.3'							
Reducer								
Invert 1	890.19'	0°	0"	18" HDPE	24"	Hole 24	-1.6"	P1
Invert 2	893.51'	180°	91.106"	18" HDPE	24"	Hole 24	38.24"	P1
Invert 3								
Invert 4								
Invert 5								
Invert 6								
Invert 7								
Invert 8								

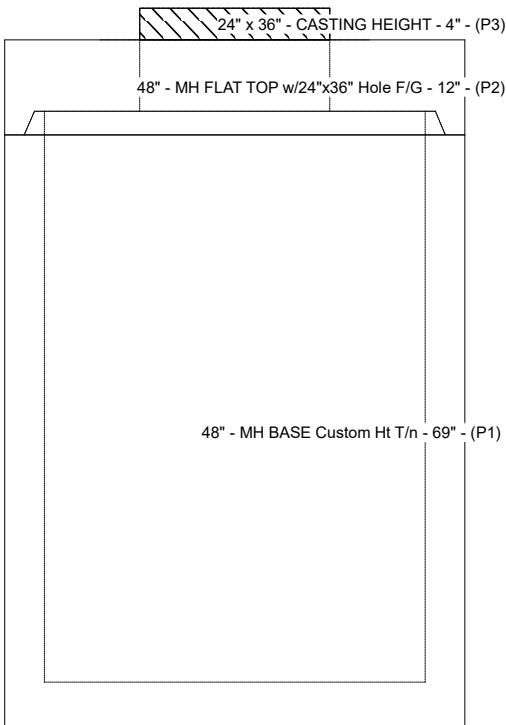

Default - Interior Dimensions

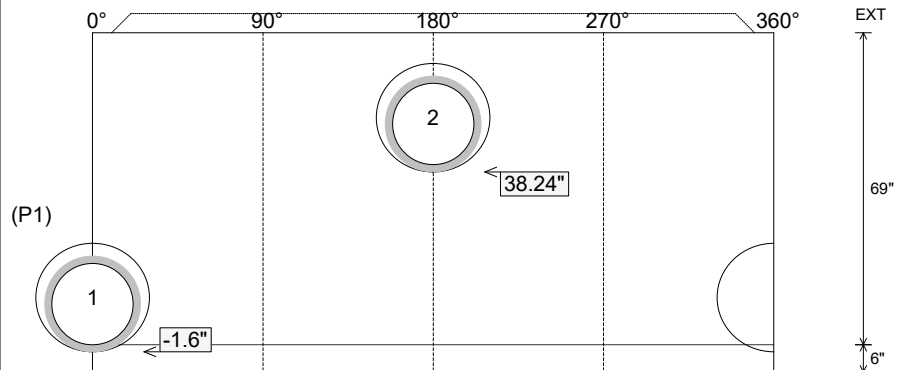

Submittal Drawing
 9/18/2025 6:45:03 AM

SUBMITTAL
 APPROVED BY:

Job Name: 25-3292 Arbor View Sec. 2
Job Location: Eminence, KY
Contractor: Core & Main LP (Lou)

PC: J.Jarvis
 TECH: C.Russ
 Plant: Beaver Dam



Structure ID: **MH-A4**

Spec: Storm
 Type: STM.MH (Recessed pipe)
 Size: 48"

Rim: 890.72'
 Invert: 886.25'
 Rim to Invert: 4.47'

Sump: 0"
 Floor (Top): 886.25'
 Floor Height: 6"

Overall Height: 4.917'
 Slack: 0.64"

Structure Notes:

1. PER ASTM C478 SPECIFICATIONS.
2. CONCRETE = 4,000 PSI AT 28 DAYS.
3. HOE MC-315 "STORM" BY ICAST
4. REINFORCING PER ASTM A615 (GRADE 60).
 - TOP SLAB (As .62) #5 BARS AT 6" C.C.E.W..
 - RISER/WALLS (As .12)
 - FLOOR (As .31) #5 BARS AT 12" C.C.E.W.

STRUCTURE SUMMARY:

P4) 24" - CASTING HEIGHT - 7"	0 lb
P3) 24" - GRADE RING F/F - 4"	270 lb
P2) 48" - MH FLAT TOP w/ 24" ECC Hole F/G - 12"	1561 lb
P1) 48" - MH BASE T/n - 30"	3032 lb
1) 48" - SGL 1"x14.5' Butyl (2x)	0 lb
2) Hole - 24	0 lb

	0 lb
Structure Total:	4862 lb

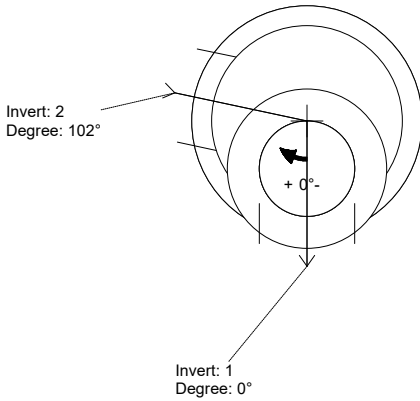

Position	Elev	Angle	Ext. (cw)	Pipe	Hole	Connector	Up (L)	Ref
Rim	890.72'							
Reducer								
Invert 1	886.25'	0°	0"	18" HDPE	24"	Hole 24	-1.6"	P1
Invert 2	886.25'	102°	51.627"	18" HDPE	24"	Hole 24	-1.6"	P1
Invert 3								
Invert 4								
Invert 5								
Invert 6								
Invert 7								
Invert 8								

Default - Interior Dimensions

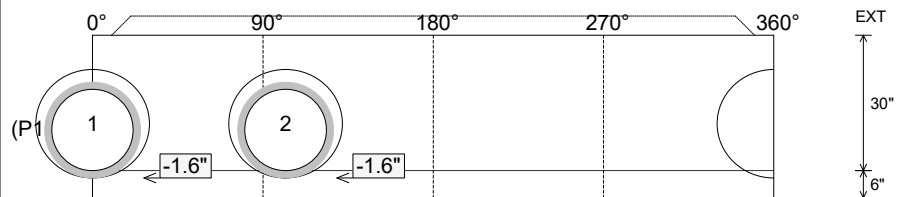
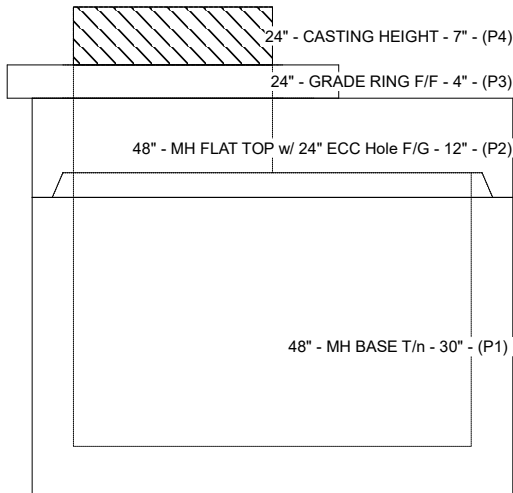

Submittal Drawing
 9/18/2025 6:45:03 AM

SUBMITTAL
 APPROVED BY:

Job Name: 25-3292 Arbor View Sec. 2
Job Location: Eminence, KY
Contractor: Core & Main LP (Lou)

PC: J.Jarvis
 TECH: C.Russ
 Plant: Beaver Dam



Structure ID: CBI-A5

Spec: Storm
 Type: BX 8inW, 8inF
 Size: 24" x 36"

Rim: 887.79'
 Invert: 883.16'
 Rim to Invert: 4.63'

Sump: 0"
 Floor (Top): 883.16'
 Floor Height: 8"

Overall Height: 5.25'
 Slack: 0.56"

Structure Notes:

1. PER ASTM C913 SPECIFICATIONS.
2. CONCRETE = 4,000 PSI AT 28 DAYS.
3. NO INVERT CHANNEL.
4. HOE 525 BY ICAST
5. REINFORCING PER ASTM A615 (GRADE 60).
 - WALLS (As .12) #5 BARS AT 12" C.C.E.W.
 - FLOOR (As .12) #5 BARS AT 12" C.C.E.W.

STRUCTURE SUMMARY:

- P2) 24" x 36" - CASTING HEIGHT - 6"
 P1) 24" x 36" - BOX BASE 8inW, 8inF, Variable Ht F/n - 49"
 1) 24" x 36" - SGL 1"x14.5' Butyl
 1) Hole - 30
 1) Hole - 24

0 lb
 5694 lb
 0 lb
 0 lb
 0 lb

Structure Total: 5694 lb

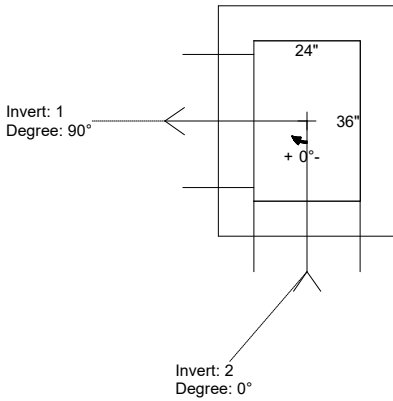

Position	Elev	Angle	Ext. (cw)	Pipe	Hole	Connector	Up (L)	Ref
Rim	887.79'							
Reducer								
Invert 1	883.16'	90°	26"	24" HDPE	30"	Hole 30	-1.9"	P1
Invert 2	883.26'	0°	20"	18" HDPE	24"	Hole 24	-0.4"	P1
Invert 3								
Invert 4								
Invert 5								
Invert 6								
Invert 7								
Invert 8								

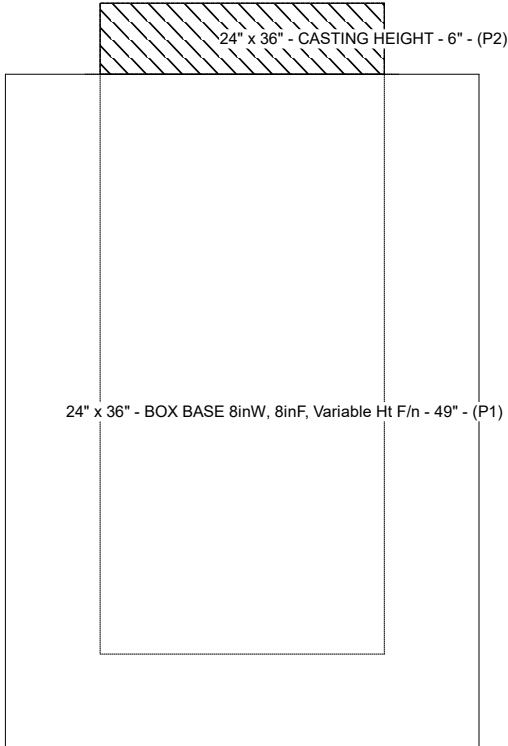

Default - Interior Dimensions

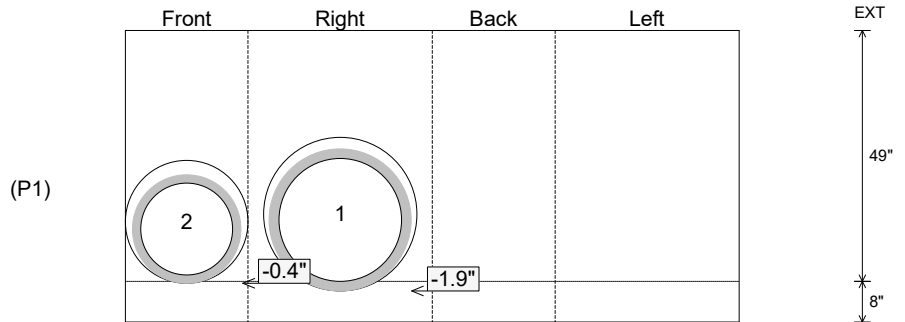

Submittal Drawing
 9/18/2025 6:45:04 AM

SUBMITTAL
 APPROVED BY:

Job Name: 25-3292 Arbor View Sec. 2
Job Location: Eminence, KY
Contractor: Core & Main LP (Lou)

PC: J.Jarvis
 TECH: C.Russ
 Plant: Beaver Dam



Structure ID: CBI-A6

Spec: Storm
 Type: STM.MH (Recessed pipe)
 Size: 60"

Rim: 887.78'
 Invert: 881.59'
 Rim to Invert: 6.19'

Sump: 2.55"
 Floor (Top): 881.378'
 Floor Height: 8"

Overall Height: 7'
 Slack: 0.83"

Structure Notes:

1. PER ASTM C478 SPECIFICATIONS.
2. CONCRETE = 4,000 PSI AT 28 DAYS.
3. HOE 525 BY ICAST
4. REINFORCING PER ASTM A615 (GRADE 60).
 - TOP SLAB (As .62) #5 BARS AT 6" C.C.E.W..
 - RISER/WALLS (As .18)
 - FLOOR (As .37) #5 BARS AT 10" C.C.E.W.

STRUCTURE SUMMARY:

- P3) 24" x 36" - CASTING HEIGHT - 6" 0 lb
 - P2) 60" - MH FLAT TOP w/24"x36" Hole F/G - 13" 4150 lb
 - P1) 60" - MH BASE Custom Ht T/n - 57" 7470 lb
 - 1) 60" - Conseal CS-102 1.00" 0 lb
 - 1) 24" x 36" - Conseal CS-102 1.00" 0 lb
 - 1) Hole - 38 0 lb
 - 1) Hole - 30 0 lb
 - 1) Hole - 24 0 lb
 - 5) MH Step ML-10-TDS-NCR - 10" 0 lb
- Structure Total: 11620 lb

IS THIS SPECIFIED AS A MANHOLE?

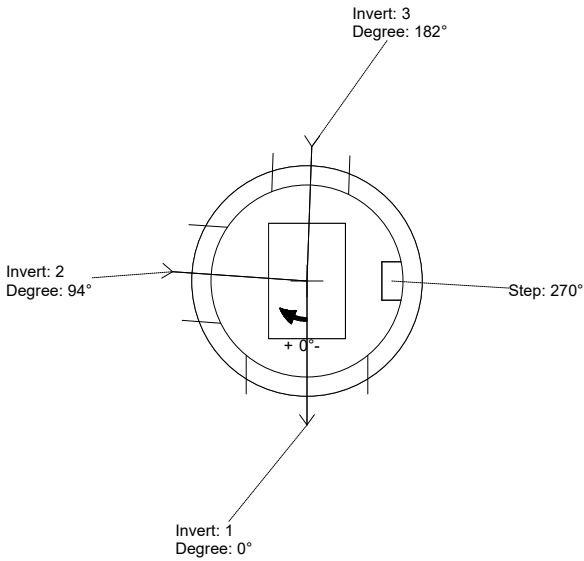

Position	Elev	Angle	Ext. (cw)	Pipe	Hole	Connector	Up (L)	Ref
Rim	887.78'							
Reducer								
Invert 1	881.59'	0°	0"	30" HDPE	38"	Hole 38	0"	P1
Invert 2	881.69'	94°	59.062"	24" HDPE	30"	Hole 30	1.85"	P1
Invert 3	883.97'	182°	114.354"	18" HDPE	24"	Hole 24	29.51"	P1
Invert 4								
Invert 5								
Invert 6								
Invert 7								
Invert 8								

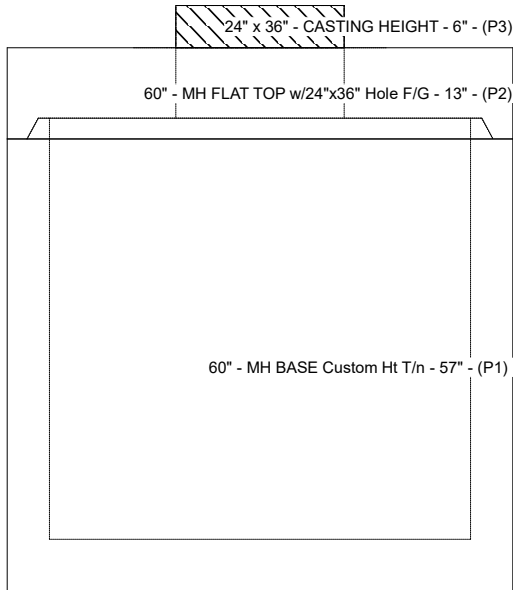

Default - Interior Dimensions

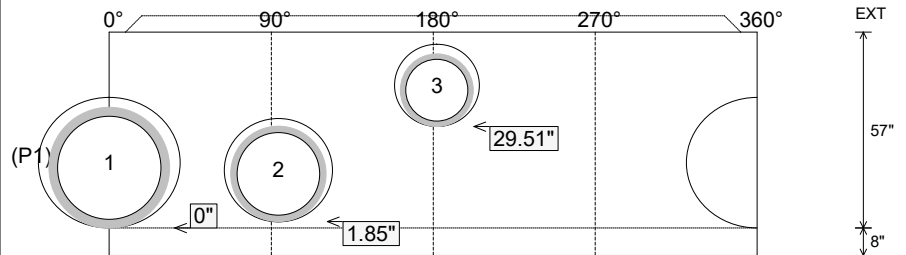

Submittal Drawing
 9/18/2025 6:45:04 AM

SUBMITTAL
 APPROVED BY:

Job Name: 25-3292 Arbor View Sec. 2
Job Location: Eminence, KY
Contractor: Core & Main LP (Lou)

PC: J.Jarvis
 TECH: C.Russ
 Plant: Beaver Dam



Structure ID: CBI-B1

Spec: Storm
 Type: BX 8inW, 8inF
 Size: 24" x 36"

Rim: 914.37'
 Invert: 911.28'
 Rim to Invert: 3.09'

Sump: 0"
 Floor (Top): 911.28'
 Floor Height: 8"

Overall Height: 3.75'
 Slack: 0.08"

Structure Notes:

1. PER ASTM C913 SPECIFICATIONS.
2. CONCRETE = 4,000 PSI AT 28 DAYS.
3. NO INVERT CHANNEL.
4. HOE 525 BY ICAST
5. REINFORCING PER ASTM A615 (GRADE 60).
 - WALLS (As .12) #5 BARS AT 12" C.C.E.W.
 - FLOOR (As .12) #5 BARS AT 12" C.C.E.W.

STRUCTURE SUMMARY:

- P2) 24" x 36" - CASTING HEIGHT - 6"
- P1) 24" x 36" - BOX BASE 8inW, 8inF, Variable Ht F/n - 31"
- 1) 24" x 36" - SGL 1"x14.5' Butyl
- 1) Hole - 24

0 lb
 4256 lb
 0 lb
 0 lb

 Structure Total: 4256 lb

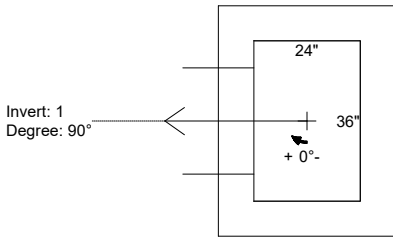

Position	Elev	Angle	Ext. (cw)	Pipe	Hole	Connector	Up (L)	Ref
Rim	914.37'							
Reducer								
Invert 1	911.28'	90°	26"	18" HDPE	24"	Hole 24	-1.6"	P1
Invert 2								
Invert 3								
Invert 4								
Invert 5								
Invert 6								
Invert 7								
Invert 8								

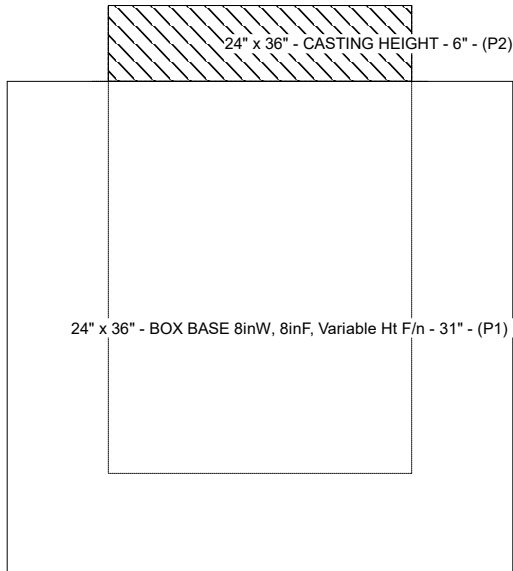

Default - Interior Dimensions

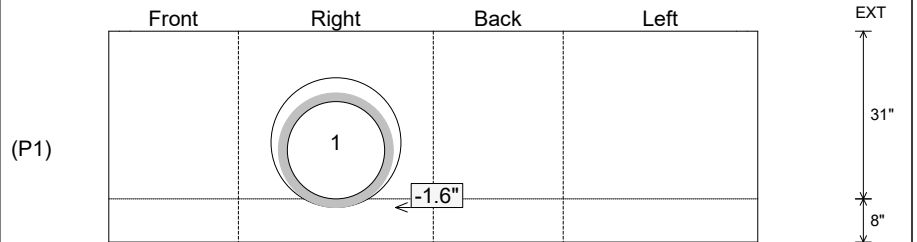

Submittal Drawing
 9/18/2025 6:45:05 AM

SUBMITTAL
 APPROVED BY:

Job Name: 25-3292 Arbor View Sec. 2
Job Location: Eminence, KY
Contractor: Core & Main LP (Lou)

PC: J.Jarvis
 TECH: C.Russ
 Plant: Beaver Dam



Structure ID: **CBI-B2**

Spec: Storm
 Type: BX 8inW, 8inF
 Size: 24" x 36"

Rim: 914.37'
 Invert: 910.48'
 Rim to Invert: 3.89'

Sump: 0"
 Floor (Top): 910.48'
 Floor Height: 8"

Overall Height: 4.5'
 Slack: 0.68"

Structure Notes:

1. PER ASTM C913 SPECIFICATIONS.
2. CONCRETE = 4,000 PSI AT 28 DAYS.
3. NO INVERT CHANNEL.
4. HOE 525 BY ICAST
5. REINFORCING PER ASTM A615 (GRADE 60).
 - WALLS (As .12) #5 BARS AT 12" C.C.E.W.
 - FLOOR (As .12) #5 BARS AT 12" C.C.E.W.

STRUCTURE SUMMARY:

- P2) 24" x 36" - CASTING HEIGHT - 6"
 P1) 24" x 36" - BOX BASE 8inW, 8inF, Variable Ht F/n - 40"
 1) 24" x 36" - SGL 1"x14.5' Butyl
 2) Hole - 24

0 lb
 4839 lb
 0 lb
 0 lb

Structure Total: 4839 lb

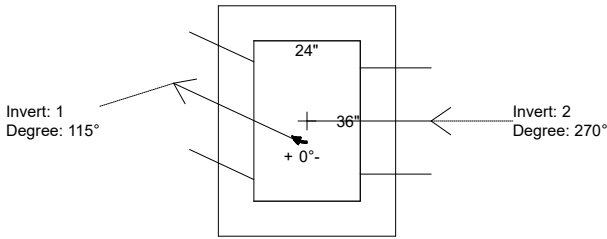

Position	Elev	Angle	Ext. (cw)	Pipe	Hole	Connector	Up (L)	Ref
Rim	914.37'							
Reducer								
Invert 1	910.48'	115°	29.809"	18" HDPE	24"	Hole 24	-1.6"	P1
Invert 2	910.49'	270°	26"	18" HDPE	24"	Hole 24	-1.48"	P1
Invert 3								
Invert 4								
Invert 5								
Invert 6								
Invert 7								
Invert 8								

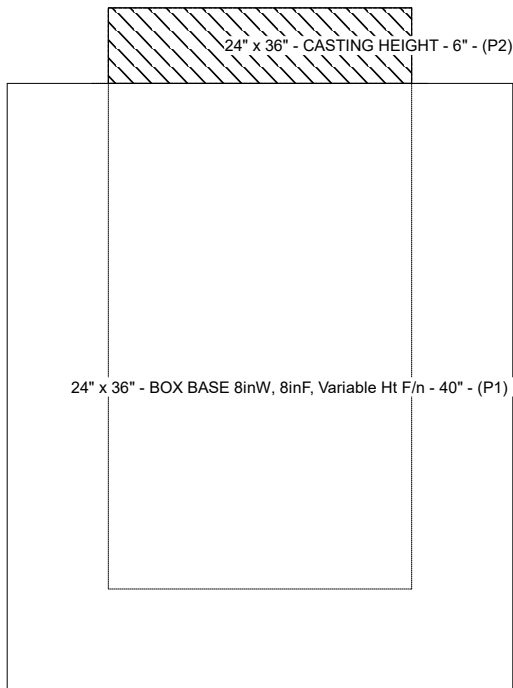

Default - Interior Dimensions

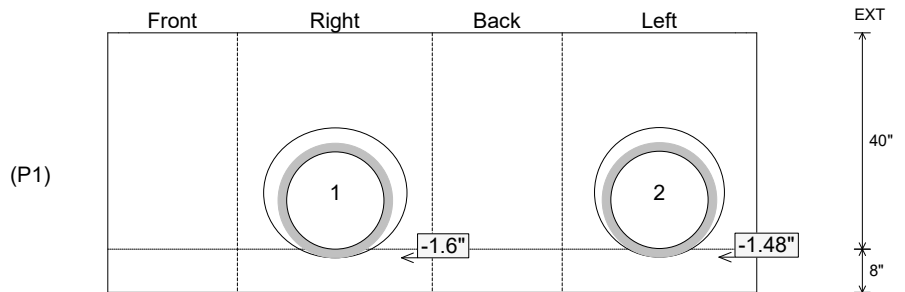

Submittal Drawing
 9/18/2025 6:45:05 AM

SUBMITTAL
 APPROVED BY:

Job Name: 25-3292 Arbor View Sec. 2
Job Location: Eminence, KY
Contractor: Core & Main LP (Lou)

PC: J.Jarvis
 TECH: C.Russ
 Plant: Beaver Dam



Structure ID: YI-B3

Spec: Storm
 Type: BX 8inW, 8inF
 Size: 24" x 36"

Rim: 911.35'
 Invert: 907.39'
 Rim to Invert: 3.96'

Sump: 0"
 Floor (Top): 907.39'
 Floor Height: 8"

Overall Height: 4.583'
 Slack: 0.52"

Structure Notes:

1. PER ASTM C913 SPECIFICATIONS.
2. CONCRETE = 4,000 PSI AT 28 DAYS.
3. NO INVERT CHANNEL.
4. HOE 518 F/G BY ICAST
5. REINFORCING PER ASTM A615 (GRADE 60).
 - WALLS (As .12) #5 BARS AT 12" C.C.E.W.
 - FLOOR (As .12) #5 BARS AT 12" C.C.E.W.

STRUCTURE SUMMARY:

- P2) 24" x 36" - CASTING HEIGHT - 4"
 P1) 24" x 36" - BOX BASE 8inW, 8inF, Variable Ht F/n - 43"
 1) 24" x 36" - SGL 1"x14.5' Butyl
 2) Hole - 24"

0 lb
 5252 lb
 0 lb
 0 lb

Structure Total: 5252 lb

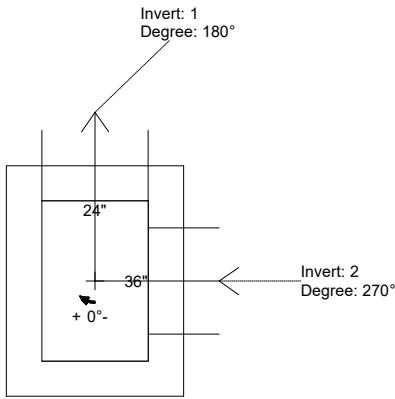

Position	Elev	Angle	Ext. (cw)	Pipe	Hole	Connector	Up (L)	Ref
Rim	911.35'							
Reducer								
Invert 1	907.39'	180°	20"	18" HDPE	24"	Hole 24	-1.6"	P1
Invert 2	907.39'	270°	26"	18" HDPE	24"	Hole 24	-1.6"	P1
Invert 3								
Invert 4								
Invert 5								
Invert 6								
Invert 7								
Invert 8								

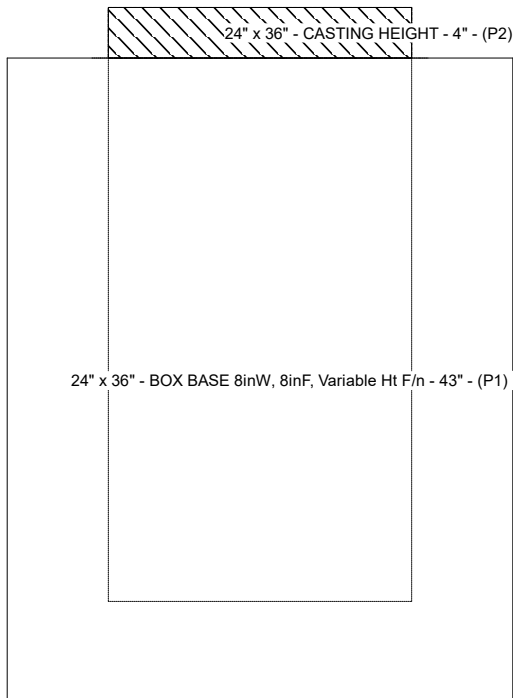

Default - Interior Dimensions

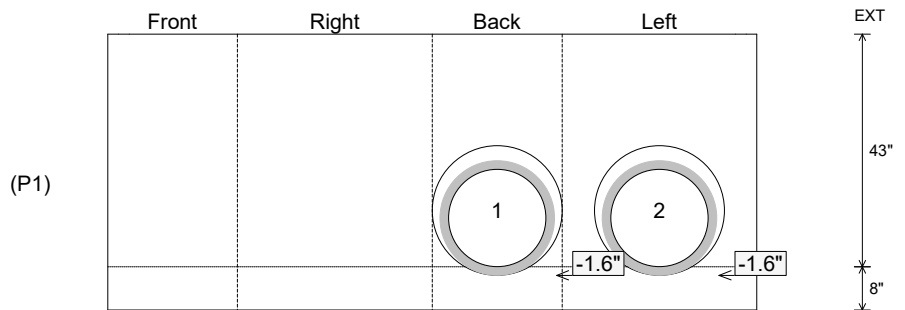

Submittal Drawing
 9/18/2025 6:45:06 AM

SUBMITTAL
 APPROVED BY:

Job Name: 25-3292 Arbor View Sec. 2
Job Location: Eminence, KY
Contractor: Core & Main LP (Lou)

PC: J.Jarvis
 TECH: C.Russ
 Plant: Beaver Dam



Structure ID: **YI-B4**

Spec: Storm
 Type: BX 8inW, 8inF
 Size: 24" x 36"

Rim: 902.37'
 Invert: 898.24'
 Rim to Invert: 4.13'

Sump: 0"
 Floor (Top): 898.24'
 Floor Height: 8"

Overall Height: 4.75'
 Slack: 0.56"

Structure Notes:

1. PER ASTM C913 SPECIFICATIONS.
2. CONCRETE = 4,000 PSI AT 28 DAYS.
3. NO INVERT CHANNEL.
4. HOE 518 F/G BY ICAST
5. REINFORCING PER ASTM A615 (GRADE 60).
 - WALLS (As .12) #5 BARS AT 12" C.C.E.W.
 - FLOOR (As .12) #5 BARS AT 12" C.C.E.W.

STRUCTURE SUMMARY:

- P2) 24" x 36" - CASTING HEIGHT - 4"
 P1) 24" x 36" - BOX BASE 8inW, 8inF, Variable Ht F/n - 45"
 1) 24" x 36" - SGL 1"x14.5' Butyl
 2) Hole - 24"

0 lb
 5456 lb
 0 lb
 0 lb

 Structure Total: 5456 lb

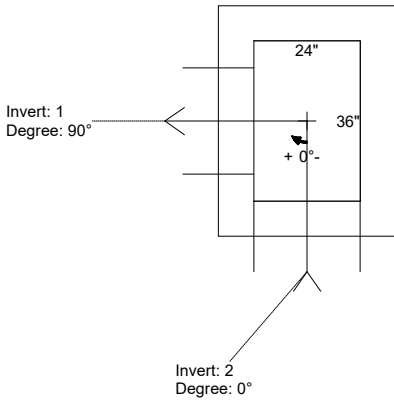

Position	Elev	Angle	Ext. (cw)	Pipe	Hole	Connector	Up (L)	Ref
Rim	902.37'							
Reducer								
Invert 1	898.24'	90°	26"	18" HDPE	24"	Hole 24	-1.6"	P1
Invert 2	898.24'	0°	20"	18" HDPE	24"	Hole 24	-1.6"	P1
Invert 3								
Invert 4								
Invert 5								
Invert 6								
Invert 7								
Invert 8								

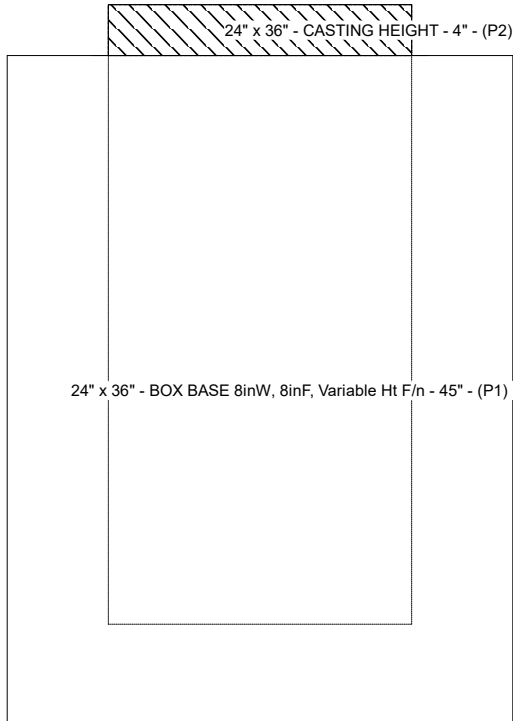

Default - Interior Dimensions

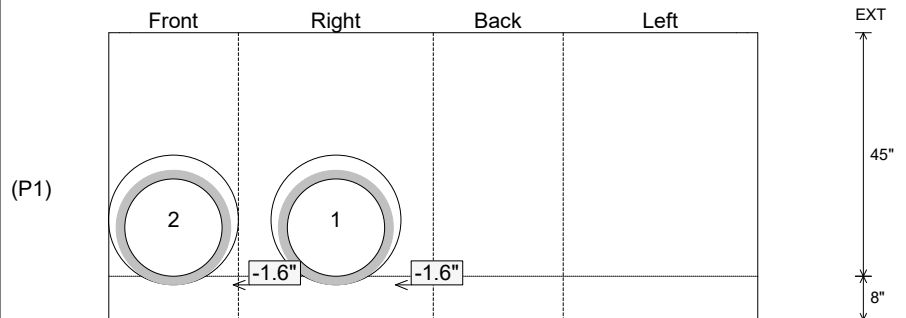

Submittal Drawing
 9/18/2025 6:45:06 AM

SUBMITTAL
 APPROVED BY:

Job Name: 25-3292 Arbor View Sec. 2
Job Location: Eminence, KY
Contractor: Core & Main LP (Lou)

PC: J.Jarvis
 TECH: C.Russ
 Plant: Beaver Dam



Structure ID: **CBI-B5**
 Spec: Storm
 Type: BX 8inW, 8inF
 Size: 24" x 36"

Rim: 900.01'
 Invert: 895.81'
 Rim to Invert: 4.2'

Sump: 0"
 Floor (Top): 895.81'
 Floor Height: 8"

Overall Height: 4.833'
 Slack: 0.4"

Structure Notes:

1. PER ASTM C913 SPECIFICATIONS.
2. CONCRETE = 4,000 PSI AT 28 DAYS.
3. NO INVERT CHANNEL.
4. HOE 525 BY ICAST
5. REINFORCING PER ASTM A615 (GRADE 60).
 - WALLS (As .12) #5 BARS AT 12" C.C.E.W.
 - FLOOR (As .12) #5 BARS AT 12" C.C.E.W.

STRUCTURE SUMMARY:

P2) 24" x 36" - CASTING HEIGHT - 6"
 P1) 24" x 36" - BOX BASE 8inW, 8inF, Variable Ht F/n - 44"
 1) 24" x 36" - SGL 1"x14.5' Butyl
 2) Hole - 24

0 lb
 5279 lb
 0 lb
 0 lb

 Structure Total: 5279 lb

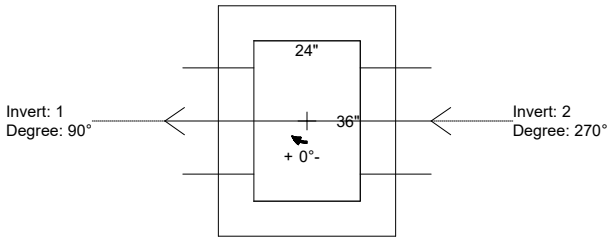

Position	Elev	Angle	Ext. (cw)	Pipe	Hole	Connector	Up (L)	Ref
Rim	900.01'							
Reducer								
Invert 1	895.81'	90°	26"	18" HDPE	24"	Hole 24	-1.6"	P1
Invert 2	895.81'	270°	26"	18" HDPE	24"	Hole 24	-1.6"	P1
Invert 3								
Invert 4								
Invert 5								
Invert 6								
Invert 7								
Invert 8								

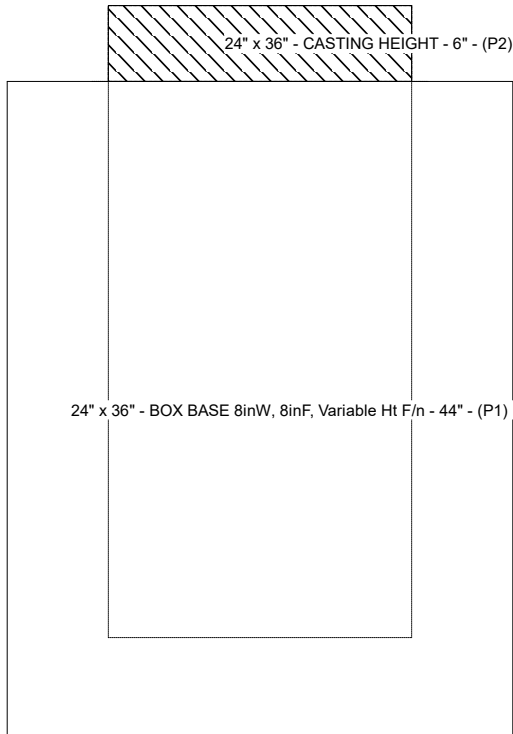

Default - Interior Dimensions

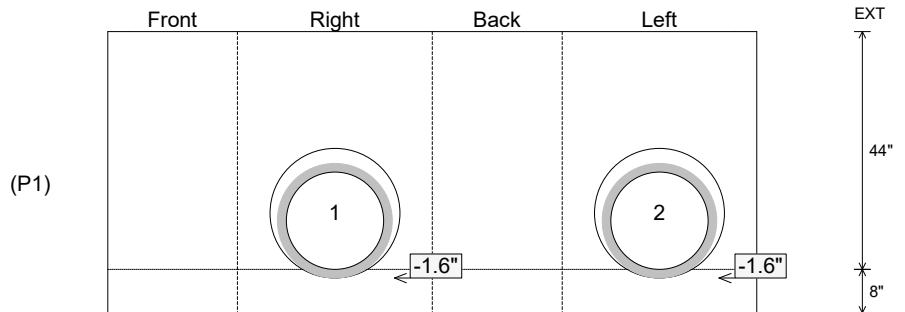

Submittal Drawing
 9/18/2025 6:45:07 AM

SUBMITTAL
 APPROVED BY:

Job Name: 25-3292 Arbor View Sec. 2
Job Location: Eminence, KY
Contractor: Core & Main LP (Lou)

PC: J.Jarvis
 TECH: C.Russ
 Plant: Beaver Dam



Structure ID: **CBI-B6**

Spec: Storm
 Type: BX 8inW, 8inF
 Size: 36" x 36"

Rim: 900.08'
 Invert: 895.33'
 Rim to Invert: 4.75'

Sump: 0"
 Floor (Top): 895.33'
 Floor Height: 8"

Overall Height: 5.417'
 Slack: 0"

Structure Notes:

1. PER ASTM C913 SPECIFICATIONS.
2. CONCRETE = 4,000 PSI AT 28 DAYS.
3. NO INVERT CHANNEL.
4. HOE 525 BY ICAST
5. REINFORCING PER ASTM A615 (GRADE 60).
 - TOP SLAB (As.62 #5 BARS AT 6" C.C.E.W.
 - WALLS (As .12) #5 BARS AT 12" C.C.E.W.
 - FLOOR (As .12) #5 BARS AT 12" C.C.E.W.

STRUCTURE SUMMARY:

P3) 24" x 36" - CASTING HEIGHT - 6"	0 lb
P2) 36" x 36" - CB FLAT TOP 8"W w/24"x36" HOLE F/F - 8"	1235 lb
P1) 36" x 36" - BOX BASE 8inW, 8inF, Variable Ht F/n - 43"	5965 lb
1) 36" x 36" - SGL 1"x14.5' Butyl (2x)	0 lb
3) Hole - 24	0 lb

Structure Total:	7200 lb

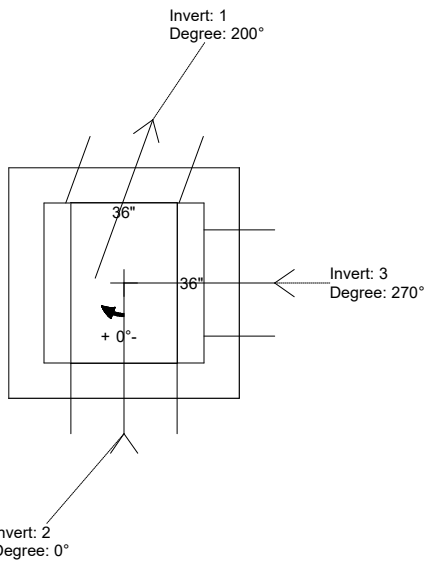

Position	Elev	Angle	Ext. (cw)	Pipe	Hole	Connector	Up (L)	Ref
Rim	900.08'							
Reducer								
Invert 1	895.33'	200°	28.568"	18" HDPE	24"	Hole 24	-1.6"	P1
Invert 2	895.43'	0°	26"	18" HDPE	24"	Hole 24	-0.4"	P1
Invert 3	895.43'	270°	26"	18" HDPE	24"	Hole 24	-0.4"	P1
Invert 4								
Invert 5								
Invert 6								
Invert 7								
Invert 8								

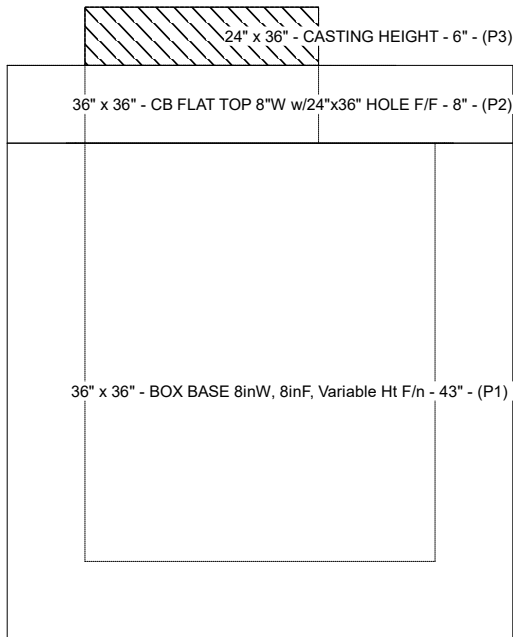

Default - Interior Dimensions

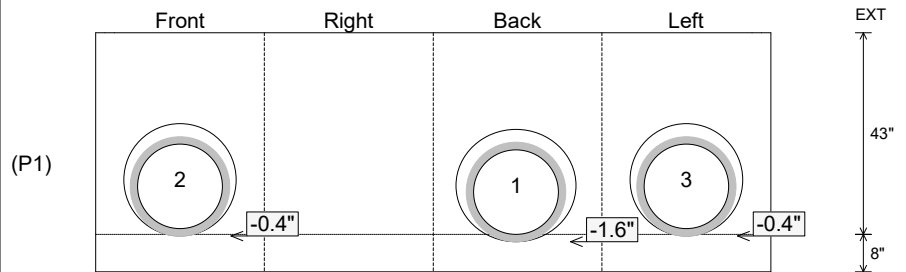

Submittal Drawing
 9/18/2025 6:45:08 AM

SUBMITTAL
 APPROVED BY:

Job Name: 25-3292 Arbor View Sec. 2
Job Location: Eminence, KY
Contractor: Core & Main LP (Lou)

PC: J.Jarvis
 TECH: C.Russ
 Plant: Beaver Dam



Structure ID: **CBI-C1**
 Spec: Storm
 Type: BX 8inW, 8inF
 Size: 24" x 36"

Rim: 908.83'
 Invert: 905.64'
 Rim to Invert: 3.19'

Sump: 0"
 Floor (Top): 905.64'
 Floor Height: 8"

Overall Height: 3.833'
 Slack: 0.28"

Structure Notes:

1. PER ASTM C913 SPECIFICATIONS.
2. CONCRETE = 4,000 PSI AT 28 DAYS.
3. NO INVERT CHANNEL.
4. HOE 525 BY ICAST
5. REINFORCING PER ASTM A615 (GRADE 60).
 - WALLS (As .12) #5 BARS AT 12" C.C.E.W.
 - FLOOR (As .12) #5 BARS AT 12" C.C.E.W.

STRUCTURE SUMMARY:

P2) 24" x 36" - CASTING HEIGHT - 6"
 P1) 24" x 36" - BOX BASE 8inW, 8inF, Variable Ht F/n - 32"
 1) 24" x 36" - SGL 1"x14.5' Butyl
 1) Hole - 24

0 lb
 4358 lb
 0 lb

 0 lb
 Structure Total: 4358 lb

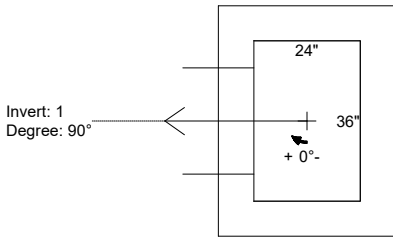

Position	Elev	Angle	Ext. (cw)	Pipe	Hole	Connector	Up (L)	Ref
Rim	908.83'							
Reducer								
Invert 1	905.64'	90°	26"	18" HDPE	24"	Hole 24	-1.6"	P1
Invert 2								
Invert 3								
Invert 4								
Invert 5								
Invert 6								
Invert 7								
Invert 8								

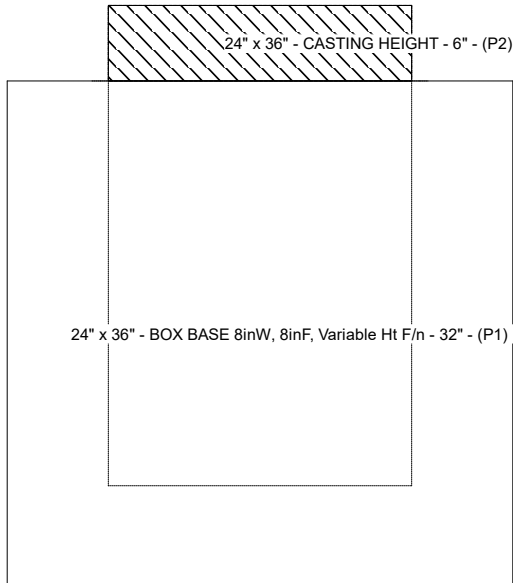

Default - Interior Dimensions

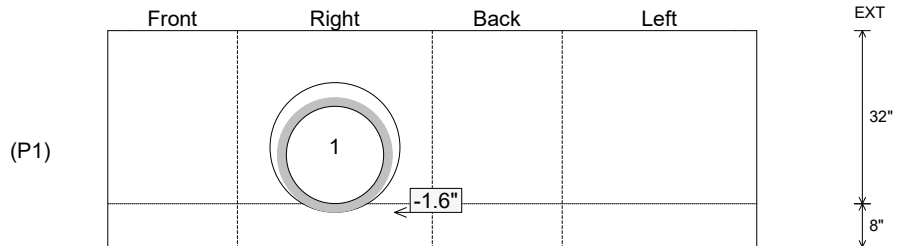

Submittal Drawing
 9/18/2025 6:45:08 AM

SUBMITTAL
 APPROVED BY:

Job Name: 25-3292 Arbor View Sec. 2
Job Location: Eminence, KY
Contractor: Core & Main LP (Lou)

PC: J.Jarvis
 TECH: C.Russ
 Plant: Beaver Dam



Structure ID: **CBI-C2**
 Spec: Storm
 Type: BX 8inW, 8inF
 Size: 24" x 36"

Rim: 908.83'
 Invert: 905.52'
 Rim to Invert: 3.31'

Sump: 0"
 Floor (Top): 905.52'
 Floor Height: 8"

Overall Height: 3.917'
 Slack: 0.72"

Structure Notes:

1. PER ASTM C913 SPECIFICATIONS.
2. CONCRETE = 4,000 PSI AT 28 DAYS.
3. NO INVERT CHANNEL.
4. HOE 525 BY ICAST
5. REINFORCING PER ASTM A615 (GRADE 60).
 - WALLS (As .12) #5 BARS AT 12" C.C.E.W.
 - FLOOR (As .12) #5 BARS AT 12" C.C.E.W.

STRUCTURE SUMMARY:

P2) 24" x 36" - CASTING HEIGHT - 6"
 P1) 24" x 36" - BOX BASE 8inW, 8inF, Variable Ht F/n - 33"
 1) 24" x 36" - SGL 1"x14.5' Butyl
 2) Hole - 24

0 lb
 4232 lb
 0 lb
 0 lb

 Structure Total: 4232 lb

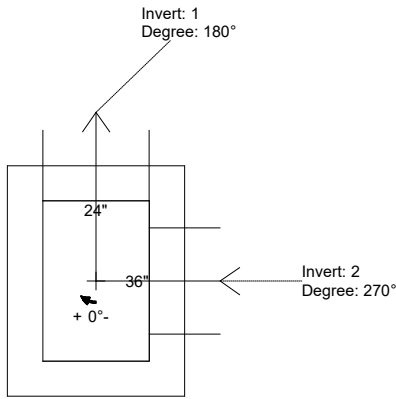

Position	Elev	Angle	Ext. (cw)	Pipe	Hole	Connector	Up (L)	Ref
Rim	908.83'							
Reducer								
Invert 1	905.52'	180°	20"	18" HDPE	24"	Hole 24	-1.6"	P1
Invert 2	905.52'	270°	26"	18" HDPE	24"	Hole 24	-1.6"	P1
Invert 3								
Invert 4								
Invert 5								
Invert 6								
Invert 7								
Invert 8								

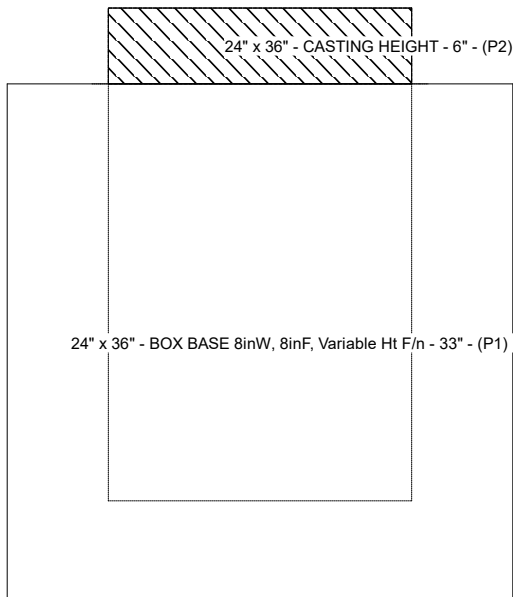

Default - Interior Dimensions

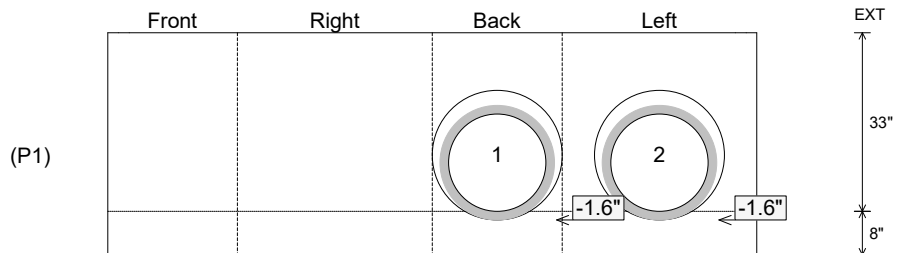

Submittal Drawing
 9/18/2025 6:45:09 AM

SUBMITTAL
 APPROVED BY:

Job Name: 25-3292 Arbor View Sec. 2
Job Location: Eminence, KY
Contractor: Core & Main LP (Lou)

PC: J.Jarvis
 TECH: C.Russ
 Plant: Beaver Dam



Structure ID: CBI-C3

Spec: Storm
 Type: STM.MH (Recessed pipe)
 Size: 48"

Rim: 897.76'
 Invert: 893.1'
 Rim to Invert: 4.66'

Sump: 0"
 Floor (Top): 893.1'
 Floor Height: 6"

Overall Height: 5'
 Slack: 1.92"

Structure Notes:

- PER ASTM C478 SPECIFICATIONS.
- CONCRETE = 4,000 PSI AT 28 DAYS.
- HOE 525 BY ICAST.
- REINFORCING PER ASTM A615 (GRADE 60).
 - TOP SLAB (As .62) #5 BARS AT 6" C.C.E.W..
 - RISER/WALLS (As .12)
 - FLOOR (As .31) #5 BARS AT 12" C.C.E.W.

STRUCTURE SUMMARY:

P3) 24" x 36" - CASTING HEIGHT - 6"	0 lb
P2) 48" - MH FLAT TOP w/24"x36" Hole F/G - 12"	1300 lb
P1) 48" - MH BASE T/n - 36"	3451 lb
1) 48" - SGL 1"x14.5' Butyl (2x)	0 lb
2) Hole - 24	0 lb
3) MH Step ML-10-TDS-NCR - 10"	0 lb

Structure Total:	4751 lb

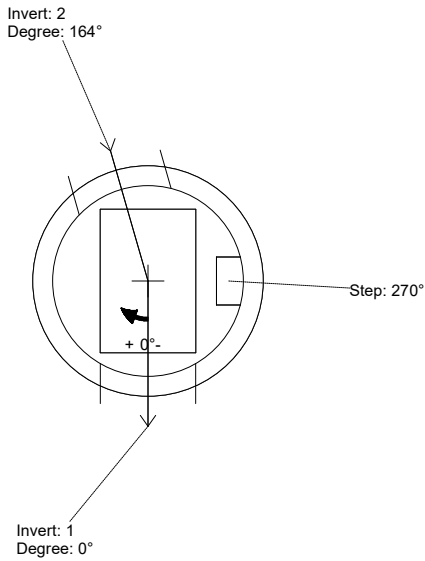

Position	Elev	Angle	Ext. (cw)	Pipe	Hole	Connector	Up (L)	Ref
Rim	897.76'							
Reducer								
Invert 1	893.1'	0°	0"	18" HDPE	24"	Hole 24	-1.6"	P1
Invert 2	893.1'	164°	83.008"	18" HDPE	24"	Hole 24	-1.6"	P1
Invert 3								
Invert 4								
Invert 5								
Invert 6								
Invert 7								
Invert 8								

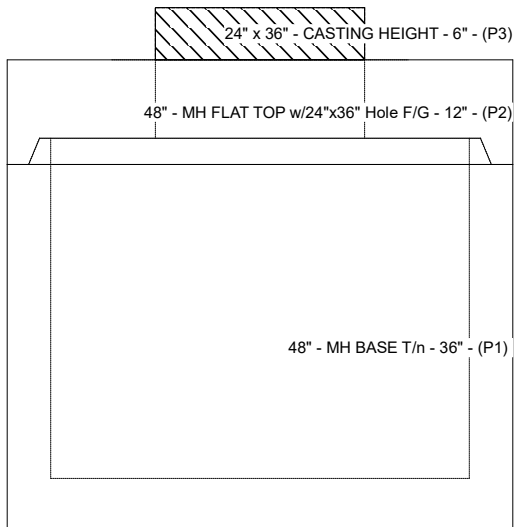

Default - Interior Dimensions

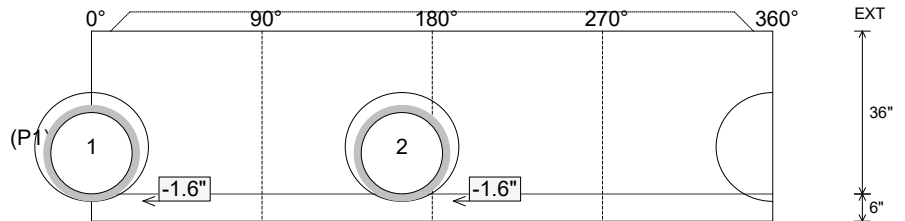

Submittal Drawing
 9/18/2025 6:45:09 AM

SUBMITTAL
 APPROVED BY:

Job Name: 25-3292 Arbor View Sec. 2
Job Location: Eminence, KY
Contractor: Core & Main LP (Lou)

PC: J.Jarvis
 TECH: C.Russ
 Plant: Beaver Dam



Structure ID: CBI-D1

Spec: Storm
 Type: BX 8inW, 8inF
 Size: 24" x 36"

Rim: 916.58'
 Invert: 912.79'
 Rim to Invert: 3.79'

Sump: 0"
 Floor (Top): 912.79'
 Floor Height: 8"

Overall Height: 4.417'
 Slack: 0.48"

Structure Notes:

1. PER ASTM C913 SPECIFICATIONS.
2. CONCRETE = 4,000 PSI AT 28 DAYS.
3. NO INVERT CHANNEL.
4. HOE 525 BY ICAST
5. REINFORCING PER ASTM A615 (GRADE 60).
 - WALLS (As .12) #5 BARS AT 12" C.C.E.W.
 - FLOOR (As .12) #5 BARS AT 12" C.C.E.W.

STRUCTURE SUMMARY:

- P2) 24" x 36" - CASTING HEIGHT - 6"
 P1) 24" x 36" - BOX BASE 8inW, 8inF, Variable Ht F/n - 39"
 1) 24" x 36" - SGL 1"x14.5' Butyl
 1) Hole - 24

0 lb
 5072 lb
 0 lb
 0 lb

Structure Total: 5072 lb

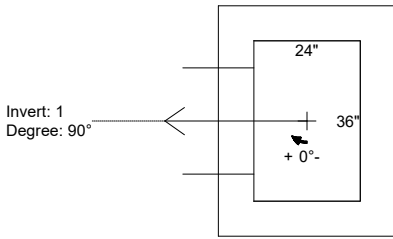

Position	Elev	Angle	Ext. (cw)	Pipe	Hole	Connector	Up (L)	Ref
Rim	916.58'							
Reducer								
Invert 1	912.79'	90°	26"	18" HDPE	24"	Hole 24	-1.6"	P1
Invert 2								
Invert 3								
Invert 4								
Invert 5								
Invert 6								
Invert 7								
Invert 8								

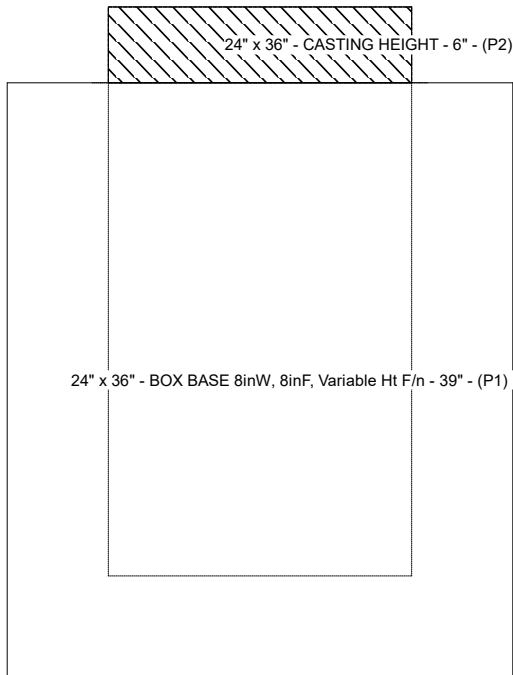

Default - Interior Dimensions

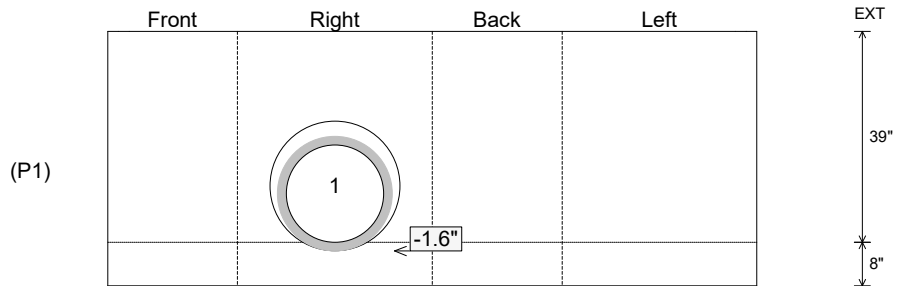

Submittal Drawing
 9/18/2025 6:45:10 AM

SUBMITTAL
 APPROVED BY:

Job Name: 25-3292 Arbor View Sec. 2
Job Location: Eminence, KY
Contractor: Core & Main LP (Lou)

PC: J.Jarvis
 TECH: C.Russ
 Plant: Beaver Dam



Structure ID: CBI-D2

Spec: Storm
 Type: BX 8inW, 8inF
 Size: 24" x 36"

Rim: 916.58'
 Invert: 912.5'
 Rim to Invert: 4.08'

Sump: 0"
 Floor (Top): 912.5'
 Floor Height: 8"

Overall Height: 4.667'
 Slack: 0.96"

Structure Notes:

1. PER ASTM C913 SPECIFICATIONS.
2. CONCRETE = 4,000 PSI AT 28 DAYS.
3. NO INVERT CHANNEL.
4. HOE 525 BY ICAST
5. REINFORCING PER ASTM A615 (GRADE 60).
 - WALLS (As .12) #5 BARS AT 12" C.C.E.W.
 - FLOOR (As .12) #5 BARS AT 12" C.C.E.W.

STRUCTURE SUMMARY:

- P2) 24" x 36" - CASTING HEIGHT - 6"
 P1) 24" x 36" - BOX BASE 8inW, 8inF, Variable Ht F/n - 42"
 1) 24" x 36" - SGL 1"x14.5' Butyl
 2) Hole - 24"

0 lb
 5074 lb
 0 lb
 0 lb

Structure Total: 5074 lb

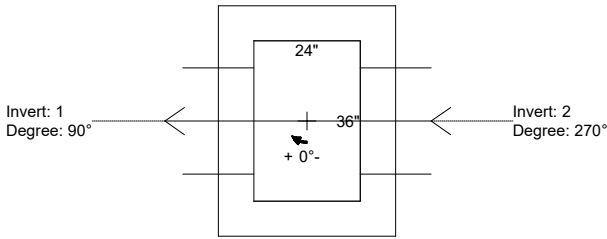

Position	Elev	Angle	Ext. (cw)	Pipe	Hole	Connector	Up (L)	Ref
Rim	916.58'							
Reducer								
Invert 1	912.5'	90°	26"	18" HDPE	24"	Hole 24	-1.6"	P1
Invert 2	912.5'	270°	26"	18" HDPE	24"	Hole 24	-1.6"	P1
Invert 3								
Invert 4								
Invert 5								
Invert 6								
Invert 7								
Invert 8								

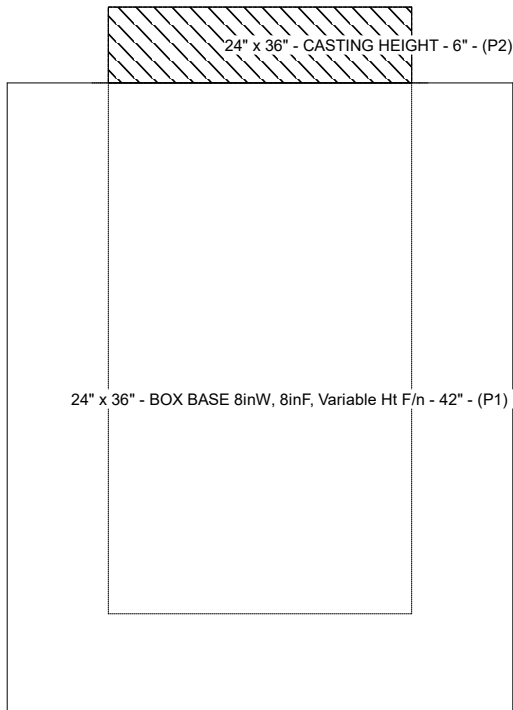

Default - Interior Dimensions

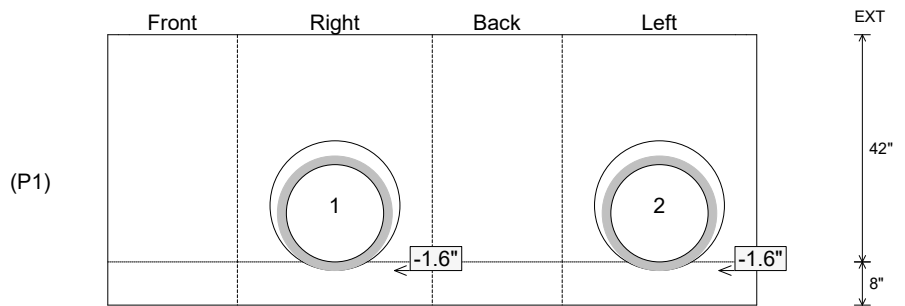

Submittal Drawing
 9/18/2025 6:45:10 AM

SUBMITTAL
 APPROVED BY:



Headwall Submittals (Typical)

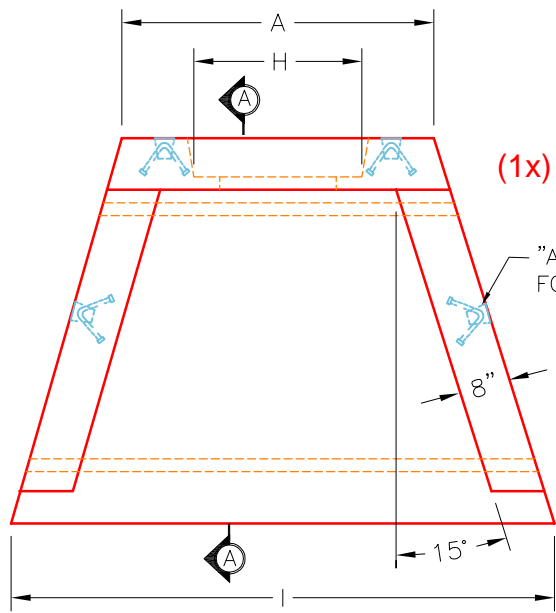

(1x) 18" S&F HW

"A-ANCHOR" LIFTING SYSTEM FOR PLANT & FIELD HANDLING.

PLAN VIEW

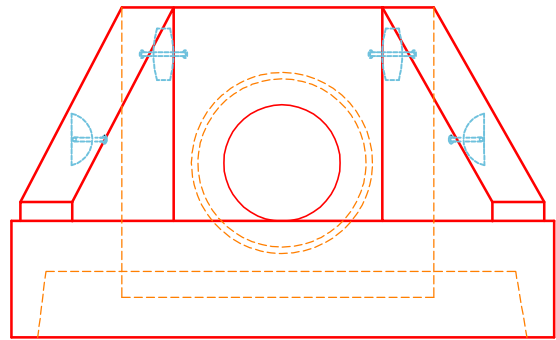

FRONT ELEVATION

DIMENSIONS										
PIPE ϕ	A	B	C	D	E	F	G	H	I	WEIGHT
12"	2'-9"	3'-6"	2'-0"	1'-6"	4'-0"	3"	2 $\frac{3}{8}$ "	1'-6"	4'-9"	3,161 LBS.
15"	2'-9"	3'-6"	2'-0"	1'-6"	4'-0"	3"	2 $\frac{3}{8}$ "	1'-10"	4'-9"	3,161 LBS.
18"	3'-6"	4'-4"	2'-10"	1'-6"	5'-0"	4"	3 $\frac{1}{4}$ "	2'-2"	6'-0"	5,127 LBS.
24"	3'-6"	4'-4"	2'-10"	1'-6"	5'-0"	4"	3 $\frac{1}{4}$ "	2'-10"	6'-0"	5,127 LBS.

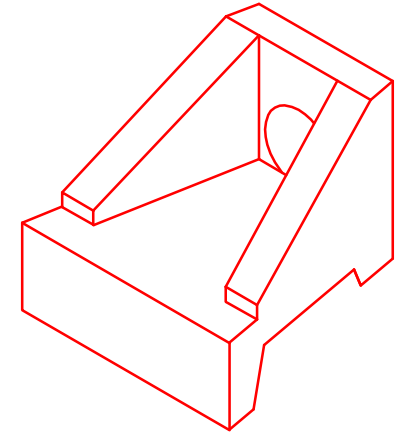

ISOMETRIC VIEW

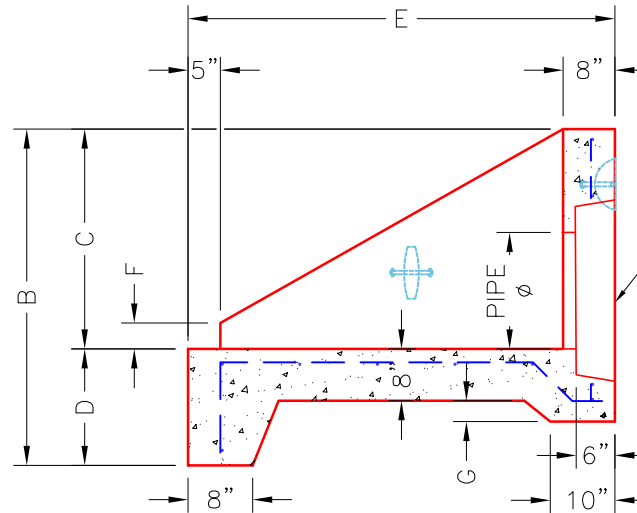

SECTION A-A

STEPPED HOLE FORMER FOR CORRESPONDING PIPE ϕ . (PIPE O.D. + 3"-4")

~NOTES:

1. CONCRETE: KYTC APPROVED.
2. REINFORCING: #4 BAR @ 12" C/C E.W.-GRADE 60, (WITH 2" CONCRETE COVER MINIMUM)
3. REINFORCING BARS TO BE TACK WELDED OR TIED.
4. PIPE AND LIFTING ANCHOR POCKETS TO BE GROUTED WITH KYTC APPROVED NON-SHRINK GROUT.
5. DRAWING TO BE USED IN CONJUNCTION WITH KYTC STD. DRAWING RDH-020-03 AND THE STANDARD SPECIFICATIONS FOR ROAD AND BRIDGE CONSTRUCTION.
6. $\frac{3}{4}$ " CHAMFER ON ALL EXPOSED EDGES.
7. PREFORMED STEPPED HOLE SIZED AS PER O.D. OF PIPE + 3"-4".

APPROVED FOR DESIGN ONLY

BY: _____
DATE: _____ 1/19/2021 1:18 PM

DIVISION OF CONSTRUCTION

INFRASTRUCTURE PRECAST, INC.
981 WEST 7TH ST., BEAVER DAM, KY. 42320
PHONE: (270) 363-2238, FAX: (270) 298-7424



KYTC 12"-24" SLOPED & FLARED HEADWALL

DRAWING NO.: KYTC SF-HW DATE: 12-14-20

REVIEWED BY: J.H. ROSS, PE DRAWN BY: N. RICHARDS

WEB: WWW.ICASTINC.COM SCALE: NTS



Casting Submittals (Typical)

HOE 518 CATCH BASIN INLET FRAME & GRATE



www.jrhoe.com 800-245-5521

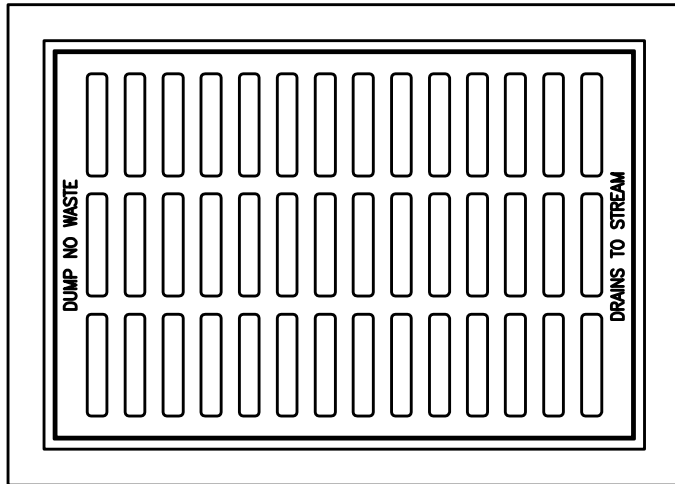

Material Specs:	ASTM A48 Class 35B, Gray Iron
Frame Weight:	143 LBS.
Grate Weight:	211 LBS.
Load Rating:	H-20
Open Drainage Area: 2.1 SQ. FT.	

Drawing Date: 04-01-12	By: SCD
Revision Date: .	By: .

LEED: Gray iron castings are eligible for LEED credits under sections MR4 Recycled Content and MR5 Regional Materials.

OPTIONS:
BICYCLE SAFE

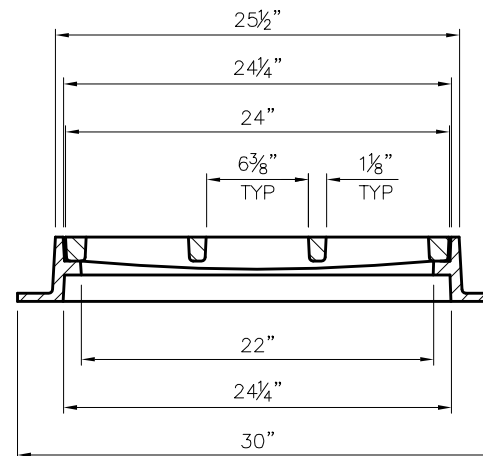
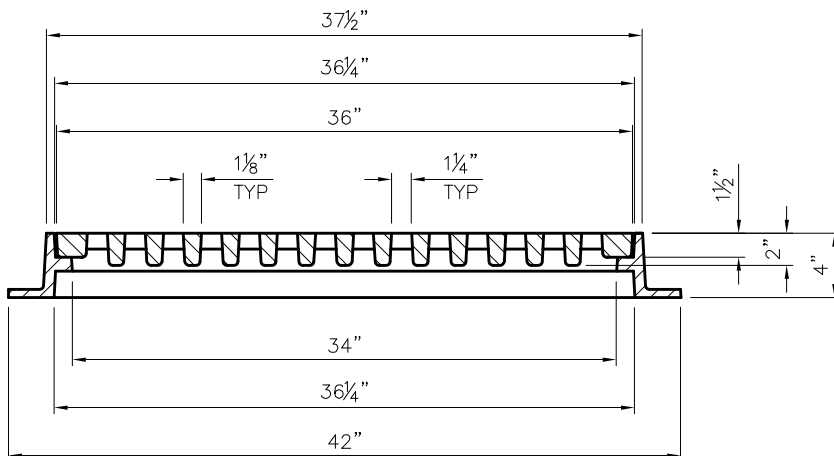

GO BACK

Drawing is the property of J. R. Hoe & Sons, Inc. and contains confidential information. J. R. Hoe & Sons, Inc. has the right to make modifications without prior notice.

HOE-525 CURB BOX INLET FRAME & TYPE C GRATE



www.irhoe.com 800-245-5521

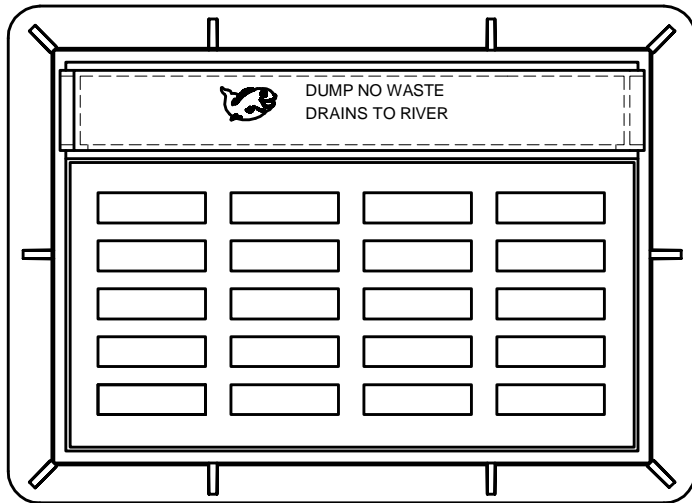

Material Specs:	ASTM A48 Class 35B, Gray Iron
Frame Weight:	193 LBS.
Grate Weight:	179 LBS.
Hood Weight:	112 LBS.
Load Rating:	H-20
Open Drainage Area: 1.8 SQ. FT.	

Drawing Date: 04-01-12	By: SCD
Revision Date: .	By: .

LEED: Gray iron castings are eligible for LEED credits under sections MR4 Recycled Content and MR5 Regional Materials.

OPTIONS:
 BICYCLE SAFE
 CURB HOOD ADJUSTABLE 6"-9"

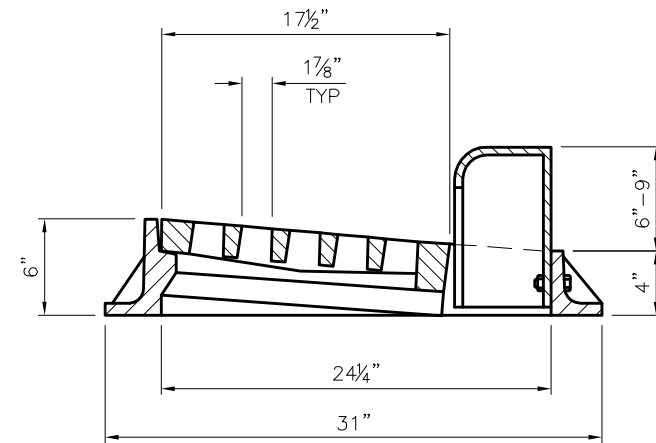
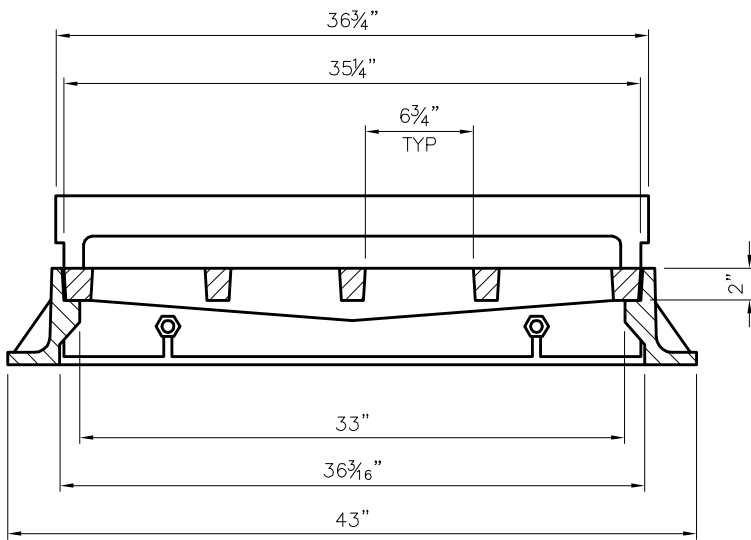

GO BACK

Drawing is the property of J. R. Hoe & Sons, Inc. and contains confidential information. J. R. Hoe & Sons, Inc. has the right to make modifications without prior notice.

HOE MC-315 ROUND MANHOLE FRAME & COVER



www.jrhoe.com 800-245-5521

Material Specs: ASTM A48
Class 35B, Gray Iron
Frame Weight: 136 LBS
Cover Weight: 122 LBS
Load Rating: H-20

Drawing Date: 04-01-12 **By:** SCD

Revision Date: . **By:** .

LEED: Gray iron castings are eligible for LEED credits under sections MR4 Recycled Content and MR5 Regional Materials.

OPTIONS:

COVER LETTERED SANITARY OR STORM,

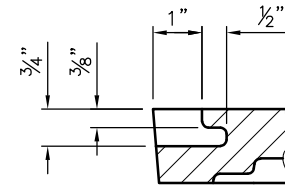
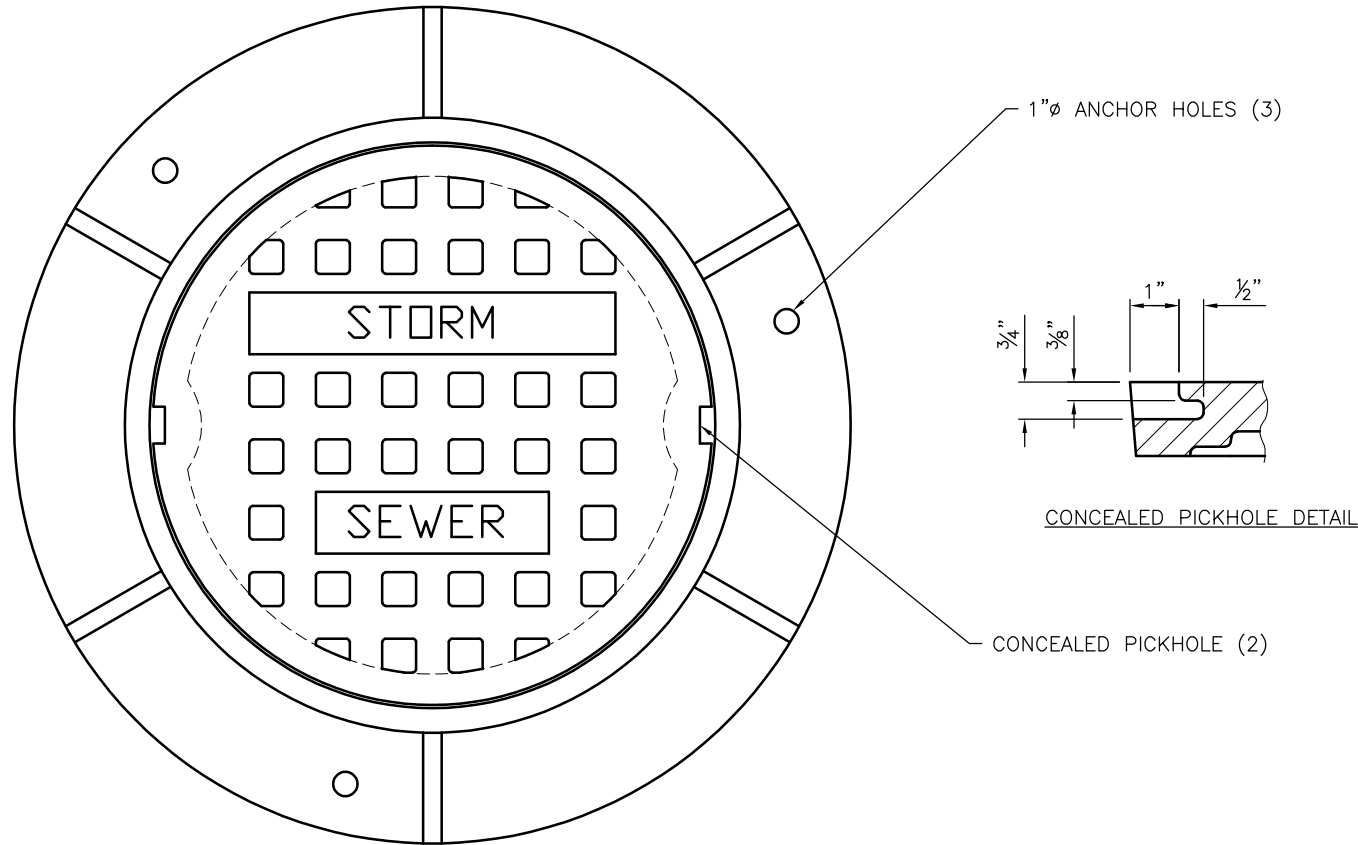

CONCEALED PICKHOLE DETAIL

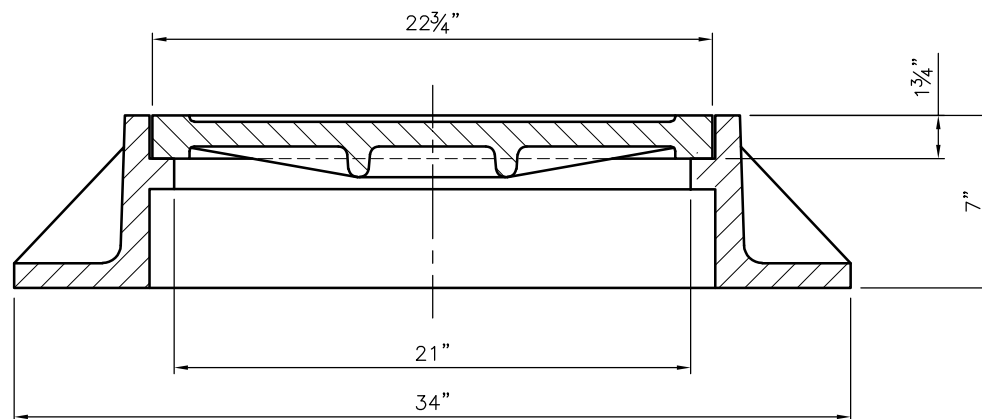

Drawing is the property of J. R. Hoe & Sons, Inc. and contains confidential information. J. R. Hoe & Sons, Inc. has the right to make modifications without prior notice.

HOE MC-315 ROUND MANHOLE FRAME & COVER



www.irhoe.com 800-245-5521

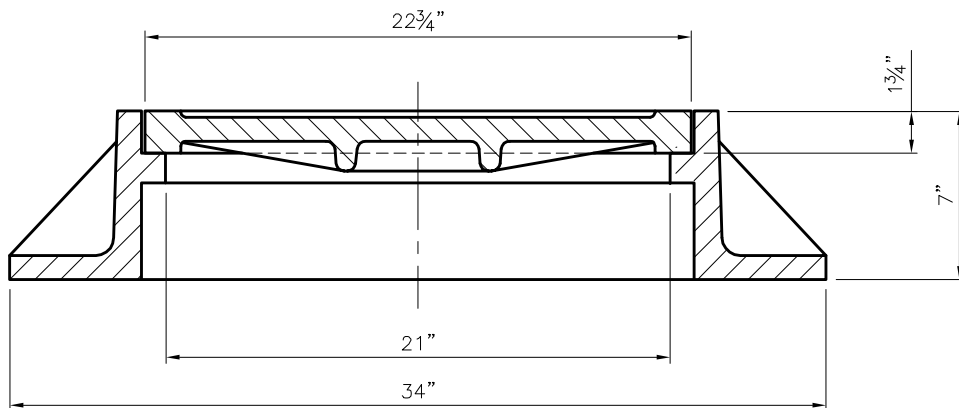
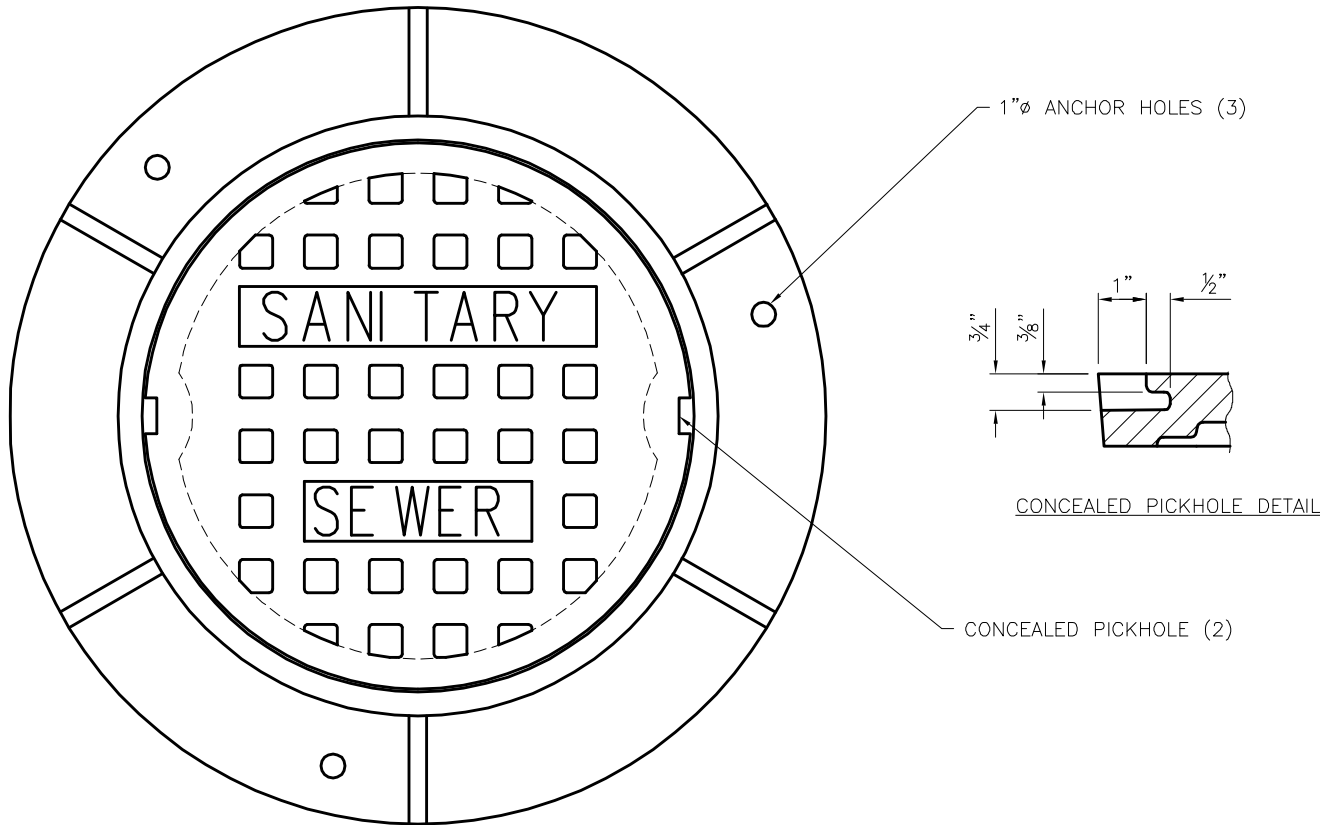

Material Specs:	ASTM A48 Class 35B, Gray Iron
Frame Weight:	136 LBS
Cover Weight:	122 LBS
Load Rating:	H-20

Drawing Date:	04-01-12	By:	SCD
Revision Date:	.	By:	.

LEED: Gray iron castings are eligible for LEED credits under sections MR4 Recycled Content and MR5 Regional Materials.

OPTIONS:
COVER LETTERED SANITARY OR STORM.

Drawing is the property of J. R. Hoe & Sons, Inc. and contains confidential information. J. R. Hoe & Sons, Inc. has the right to make modifications without prior notice.



Accessories (Typical)

ConSeal™ CS-102

Butyl Rubber Sealant



Butyl Rubber Sealant for All Precast Concrete Structures - Meets ASTM C-990

Applications

For concrete joints in: Manholes, Concrete Pipe, Vaults, Box Culverts, Septic Tanks, and Vertical Panel Structures. **Not intended for use in expansion joints or joints that move.**

Sealing Properties

- Provides permanently flexible watertight joints.
- Low to high temperature workability: 30°F to 120°F (-1°C to +48°C)
- Rugged service temperature: -30°F to +200°F (-34°C to +93°C)
- Excellent chemical and mechanical adhesion to clean dry surfaces.
- Greater cohesive and adhesive strengths.
- Sealed joints will not shrink, harden or oxidize upon aging.
- Controlled flow resistance for application ease.
- No priming normally necessary. When confronted with difficult installation conditions, such as wet concrete or temperatures below 40°F (4°C), priming the concrete will improve the bonding action. Consult Concrete Sealants for the proper primer to meet your application.

Hydrostatic Strength

ConSeal CS-102 meets the hydrostatic performance requirement as set forth in ASTM C-990 section 10.1 (Performance requirement: 10psi for 10 minutes in straight alignment – in plant, quality control test for joint materials.)

Specifications

ConSeal CS-102 meets or exceeds all of the requirements of Federal Specification SS-S-210 (210-A), AASHTO M-198B, and ASTM C-990-91.

Physical Properties

Description

	Spec	Required	CS-102
Color			Black
Specific Gravity, 77°F	ASTM D71	1.15-1.50	1.25
Ductility, 77°F	ASTM D113	5.0 min.	10
Penetration, cone 77°F (25°C), 150 gm, 5 sec.	ASTM D217	50-100 mm	55-60 mm
Penetration, cone 32°F (0°C), 150 gm, 5 sec.	ASTM D217	40 mm min.	40-65 mm
Flash Point, C.O.C., °F	ASTM D92	350°F min.	450°F
Fire Point, C.O.C., °F	ASTM D92	375°F min.	475°F

Don't Just Seal It, ConSeal It!

© 2018 Concrete Sealants, Inc.

Concrete Sealants, Inc. 9325 State Route 201 ■ Tipp City, OH 45371 ■ Toll Free 800.332.7325

P. 937.845.8776 **F.** 937.845.3587 ■ www.conseal.com



Concrete Sealants, Inc.
ISO 9001:2015 Registered

ConSeal™ CS-102

Butyl Rubber Sealant



Butyl Rubber Sealant for All Precast Concrete Structures - Meets ASTM C-990

Chemical Composition

Description

	Spec	Required	CS-102
Hydrocarbon plastic content % by weight	ASTM D297	50% min.	51%
Inert mineral filler % by weight	AASHTO T111	30% min.	35%
Volatile Mater % by weight	ASTM D6	2% max.	1.2%
Non-extractable, carbon-based material			12.8%
Recycled Content, % by weight			
Post Consumer:			8.41%
Post Industrial:			10.85%

Immersion Testing

30-Day Immersion Testing: No visible deterioration when tested in 5% Caustic Potash, 5% Hydrochloric Acid, 5% Sulfuric Acid, and 5% saturated Hydrogen Sulfide.

One Year Immersion Testing: No visible deterioration when tested in 5% Formaldehyde, 5% Formic Acid, 5% Sulfuric Acid, 5% Hydrochloric Acid, 5% Sodium Hydroxide, 5% Hydrogen Sulfide, and 5% Potassium Hydroxide.

Limited Warranty

This information is presented in good faith, but we cannot anticipate all conditions under which this information and our products, or the products of other manufactures in combination with our products, may be used. We accept no responsibility for results obtained by the application of this information or the safety and suitability of our products, either alone or in combination with other products. Users are advised to make their own tests to determine the safety and suitability of each such product or product combinations for their own purposes. It is the **users' responsibility** to satisfy himself as to the suitability and completeness of such information for this own particular use. We sell this product without warranty, and buyers and users assume all responsibility and liability for loss or damage arising from the handling and use of this product, whether used alone or in combination with other products.

Don't Just Seal It, ConSeal It!

© 2018 Concrete Sealants, Inc.

Concrete Sealants, Inc. 9325 State Route 201 ■ Tipp City, OH 45371 ■ **Toll Free** 800.332.7325

P. 937.845.8776 **F.** 937.845.3587 ■ www.conseal.com



Concrete Sealants, Inc.
ISO 9001:2015 Registered



The Company With Connections®

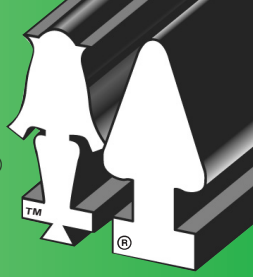

THE NEXT LEVEL OF FLEXIBLE CONNECTORS

A•LOK® PREMIUM™ ASTM C-923 APPLICATION

● A•LOK® PREMIUM™

Designed to produce a guaranteed watertight seal between pipe and concrete, the **A•LOK® Premium™** flexible pipe-to-manhole connector provides maximum performance on the job site. Its unique design not only saves valuable project time, but also ensures longevity and offers unsurpassed environmental benefits.

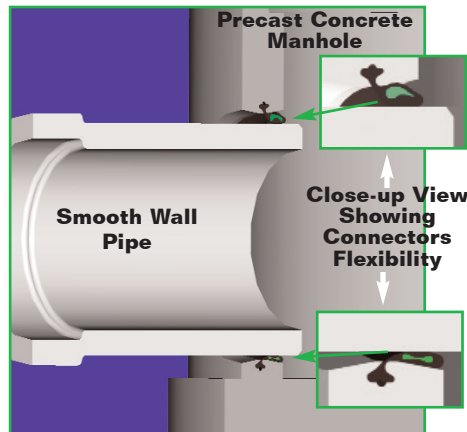

Cast in A•LOK® Premium™ Connector.
For all types of smooth wall pipe.

A•LOK® Premium™ connectors prevent infiltration and ex-filtration into wastewater or stormwater systems, and are installed in the precast structure in a way that does not require coring or placement after the base component is cast. This eliminates residual waste from coring, disposal of the slugs or wasted raw material utilization or energy. Once cast-in, the connector becomes an integral component of the structure wall.

A•LOK® Premium™ has demonstrated in tests that it will meet and exceed 13 psi of hydrostatic water pressure.

● MATERIAL

Extruded from compounds formulated for wastewater applications and engineered to conform to the requirements of section 4.1.1 of ASTM C-923, the standard rubber connector is available in alternative compounds upon request. Contact an A•LOK® representative regarding special applications, such as the presence of hydrocarbons.

● KEY ADVANTAGES

The external appearance of the **A•LOK® Premium™** connector appears to be a standard connector, but under differential loading or pipe deflection it will instantaneously react and redistribute its visco-elastic dynamic core material to maintain its circumferential sealing pressure. This visco-elasticity behavior is made possible by introducing a blend of environmentally friendly fibers, binders, polymers and congealing agents into the connector core which provides a controllable and dynamic viscous fluid within the connector. In most installations, this material will remain equally distributed throughout the core of the connector provided proper pipe bedding practices have taken place. In the event that short-term or long-term settlement of the pipe begins to occur, the core

● KEY ADVANTAGES (Continued)

material will react by redistributing and equalizing the blended materials to maintain its proper sealing compression.

A specific combination of fibers and congealing agents have been selected to prevent the escape or loss of material through absorption or from minor punctures or tears that could occur during the initial coupling of the connector and during its service life.

Benefits and advantages include:

1. Functioning on pure compression, the **A•LOK® Premium™** allows for fast and easy field installation. After the pipe is beveled and the connector and pipe are cleaned and lubricated, the pipe is simply centered in the connector and inserted. Backfilling can be done immediately, thus enhancing project safety and overcoming the typical problems of water, running sand and other unstable trench conditions.
2. Efficient geometry of the profile lowers the coupling force required to insert the pipe into both radius and flat wall connector designs. Lower coupling force translates into quicker and easier installation.
3. Increased nominal pipe diameter tolerance over conventional compression connector designs while still maintaining up to 10 degrees of omnidirectional axial deflection.
4. Dynamic self-sealing core material can compensate for changes in dimensions and physical eccentricity.
5. Available in a range of sizes from 12" through 90" utilizing existing **A•LOK®** mandrels.
6. Backed by our standard **A•LOK** Watertight Guarantee.
7. Like other **A•LOK®** connectors on larger-diameter pipe where size prohibits a gasket from being installed in a flat plane, the **A•LOK® Premium** can be configured for casting in a curve with the connector staying perpendicular to the center line of the pipe. Discovered through years of extensive research and development, this configuration causes no loss of compression or deflection.

● PRODUCT REFERENCES

A.) ASTM C-923

Resilient Connector Between Reinforced Concrete Manholes Structures, Pipe and Laterals.

B.) ASTM C-1244

Standard Test Method For Concrete Sewer Manholes by the Negative Air Pressure (Vacuum) Test

C.) ASTM C-478

Standard Specification for Precast Reinforced Concrete Manhole Sections

PERFORMANCE STANDARD

The A•LOK® Premium™ connector is guaranteed to meet or exceed all material and test requirements outlined in ASTM C-923 "Resilient Connectors Between Reinforced Concrete Manhole Structures and Laterals".

Extruded from compounds formulated for wastewater applications, the rubber connector is engineered to conform to the requirements of ASTM C-923. Alternative compounds are available upon special request.

RESILIENT TEST REQUIREMENTS OF A.S.T.M. C-923

TEST	RESULTS	ASTM METHOD
Chemical resistance 1 N Sulfuric acid 1 N Hydrochloric Acid	no weight loss no weight loss	at 22°C for 48h
Tensile strength	1200 psi or 8.5 MPa, min	D 412
Elongation at break	350% min.	
Hardness	±5 from mfg's. specified hardness	D 2240 (Shore A durometer)
Accelerated oven-aging	decr. of 15%, max. of original tensile strength, decr. of 20% max. of elongation	D 573, 70±1°C for 7 days
Compression set	decr. of 25%, max. of original deflection	D 395, Method B, at 70°C for 22h
Water absorption	increase of 10%, max. of original by weight	D 471, immerse 0.75 by 2-in. or 19 by 25-mm Specimen in distilled water at 70°C for 48h
Ozone resistance	rating 0	D 1171
Low-temp brittle point	no fracture at -40°C	D 746
Tear resistance	200 lbf/in. or 34 kn/m	D 624, Method B

Copyright ASTM INTERNATIONAL. Reprinted with permission

DIMENSIONAL DATA

Maximum Pipe O.D. Based on Manhole Diameter and Pipe Angles Using A•LOK® Premium™ Connectors.

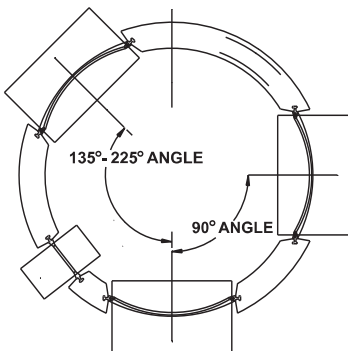

Min. distance between pipes is approx. 1/2 the smallest pipe OD

MAX. PIPE SIZE OD's

Manhole Diameter	135° - 225° Pipe Angle	90° Pipe Angle
42"	26.5"	22.0"
48"	31.5"	25.0"
60"	42.0"	32.0"
72"	52.5"	38.0"
84"	59.5"	44.0"
96"	73.5"	50.0"
108"	76.0"	56.0"
120"	87.5"	62.0"

PRODUCT SPECIFICATIONS

A flexible pipe to manhole connector shall be used whenever a pipe penetrates into a precast concrete manhole or structure. The connector shall be The A•LOK® Premium™ Connector as manufactured by A•LOK Products, Inc., Tullytown, PA or approved equal.

The design of the connector shall provide a flexible, watertight seal between the pipe and concrete structure. The connector shall assure that a seal is made between:

1. The connector and the structure wall by casting the connector integrally with the structure wall during the manufacturing process in a manner that it will not pull out during pipe coupling. The connector shall also be capable of being cast into a round structure by curving the connector in a manner that allows it to remain centrally located within the structure wall and perpendicular to the pipe. This configuration will result in no loss of seal or deflection of pipe entering a concrete structure.

2. The seal between the connector and the pipe shall be made by the compression of the connector between the outside circumference of the factory installed smooth oversleeve of a corrugated pipe or the smooth surface of a traditional pipe and the interior hole opening of the structure. The connector shall be the only component to affect the seal between the pipe and structure.

The connector shall be made from materials that conform to the physical and Section 4, "Materials and Manufacture" of ASTM C-923 Standard Specification for Resilient Connectors Between Reinforced Concrete Manhole Structures and Laterals", and the overall design will meet or exceed Section 7, "Test Methods and Requirements" of ASTM C-923. This connector shall be sized specifically for the type of pipe being used and shall be installed in accordance with the recommendations of the manufacturer.

INSTALLATION INSTRUCTIONS

Experience has shown that successful performance of this product depends on proper plant installation, as well as the backfill and the care in the field installation of the manhole or wastewater structure and connecting pipes.

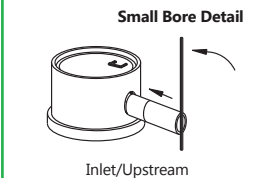
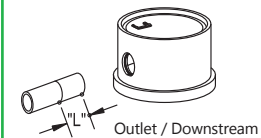
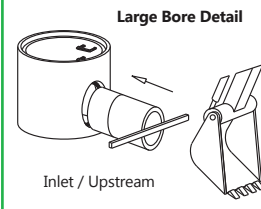
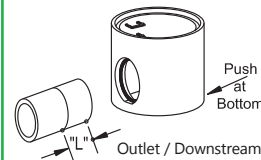

CAUTION
When installing pipe stubs for future pipeline installation, all stubs must be properly restrained to prevent any movement by means other than the A•LOK® Premium™ Connector.

STEP 1:

Confirm that the pipe surface is smooth, clean and free of foreign materials, chips, gouges and form seams due to manufacturing or handling. Slightly bevel any sharp or blunt edges caused by the cutting of the pipe.

STEP 2:

Lubricate the connector and the entire section of the pipe that will be inserted into the connector. The chart below lists A•LOK's minimum lubrication length "L".

PIPE SIZE	MIN. LUBRICATION LENGTH "L"
8" - 15"	12"
16" - 18"	18"
21" & Larger	24"

STEP 3:

Center the pipe and connector square to each other and insert the pipe into the connector using a bar or back hoe depending on the size. Once the pipe is coupled with the connector, deflect the structure or pipe to achieve the proper angle.

NOTE:

To find approximate subgrade, measure from the outside base of the structure to the junction of the connector and flat spot. Then add the wall thickness of the pipe plus 1/4 inch.

WARNING

To ensure the A•LOK® Premium™ Connector remains a flexible watertight connector, it is A•LOK Products, Inc. strong recommendation that no mortar be placed between the pipe and wall of the concrete structure. The use of mortar in this area would decrease the effectiveness of the connector to compensate for shear caused by settlement or ground movement.

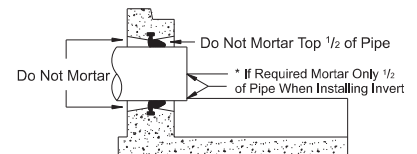



The Company With Connections®



THE NEXT LEVEL OF FLEXIBLE CONNECTORS

A-LOK® PREMIUM™ ASTM F-2510 APPLICATION

A-LOK® PREMIUM™

The A-LOK® Premium™ is a flexible compression connector designed to be integrated into a watertight system based on ASTM F-2510. When used with a corrugated pipe with a factory installed smooth oversleeve or with a smooth wall pipe, the A-LOK® Premium™ will provide a guaranteed watertight seal between the pipe and the wall of a concrete structure. Its unique design not only provides maximum performance but saves valuable project time, extends the longevity of the structures and reduces the projects overall environmental impact.

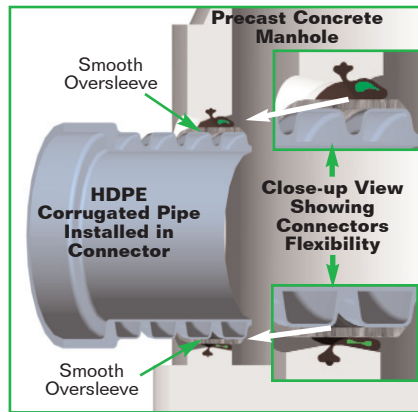

A-LOK® Premium™ Connector making a watertight connection with HDPE Corrugated Pipe using a factory installed smooth oversleeve.

A-LOK® Premium™ connectors prevent infiltration and ex-filtration about the pipe interface in wastewater or stormwater systems. They are installed in the structure in a way that does not require coring or placement as a secondary operation. This eliminates residual waste from coring, the disposal of the slugs, inefficient raw material utilization and excess energy use. Once cast-in, the connector becomes an integral component of the structure's wall.

MATERIAL

The connectors are extruded from rubber compounds that are formulated for wastewater applications and engineered to conform to the requirements of ASTM F-2510. The A-LOK® Premium™ connector is also available in alternative rubber compounds upon request. Please contact an A-LOK® representative regarding additional benefits and special applications, such as the presence of hydrocarbons.

DEFLECTION PERFORMANCE

Axial Deflection of Pipe (Angular) - 10 degrees

Outside Diameter of Pipe Deflection from Loading: 5% in accordance to ASTM F-2510

KEY ADVANTAGES

The external appearance of the A-LOK® Premium™ connectors appear to be a standard connector, but under differential loading or pipe deflection it will instantaneously react and redistribute its visco-elastic dynamic core material to maintain its circumferential sealing pressure. This visco-elasticity behavior is made possible by introducing a blend of environmentally friendly fibers, binders, polymers and congealing agents into the connector core which provides a controllable and dynamic viscous fluid within the connector. In most installations, this material will

KEY ADVANTAGES (Continued)

remain equally distributed throughout the core of the connector provided proper pipe bedding practices have taken place. In the event that short-term or long-term deflection of the pipe begins to occur, the core material will react by redistributing and equalizing the blended materials to maintain its proper sealing compression.

A specific combination of fibers and congealing agents have been selected to prevent the escape or loss of material through absorption or from minor punctures or tears that could occur during the initial coupling of the connector and during its service life.

A-LOK® Premium™ has successfully been tested to ASTM F-2510 deflection requirements of 5% without loss of seal.

Benefits and advantages include:

1. Functioning on pure compression, the A-LOK® Premium™ allows for fast and easy field installation. After the pipe is beveled and the connector and pipe are cleaned and lubricated, the pipe is simply centered in the connector and inserted. Backfilling can be done immediately, thus enhancing project safety and overcoming the typical problems of water, running sand and other unstable trench conditions.
2. Efficient geometry of the profile lowers the coupling force required to insert the pipe into both radius and flat wall connector designs. Lower coupling force translates into quicker and easier installation.
3. Increased nominal pipe diameter tolerance over conventional compression connector designs while still maintaining up to 10 degrees of omnidirectional axial deflection.
4. Connector can meet the 5% deflection requirements of ASTM F-2510 without loss of seal or compression. Dynamic self-sealing core material can compensate for changes in dimensions and physical eccentricity.
5. Available in a range of sizes from 12" through 90" utilizing existing A-LOK® mandrels.
6. Backed by standard A-LOK Watertight Guarantee.
7. Like other A-LOK® connectors on larger-diameter pipe where size prohibits a gasket from being installed in a flat plane, the A-LOK® Premium can be configured for casting in a curve with the connector staying perpendicular to the center line of the pipe. Discovered through years of extensive research and development, this configuration causes no loss of compression or deflection.

PRODUCT REFERENCES

- A.) **ASTM F-2510** – Standard Specification for Resilient Connectors Between Reinforced Concrete Manhole Structures and corrugated High Density Polyethylene Pipes.
- B.) **ASTM C-478** – Standard Specification for Precast Reinforced Concrete Manhole Sections.
- C.) **ASTM C-913** – Standard Specification for Precast Concrete Water and Wastewater Structures.

PERFORMANCE STANDARD

The A•LOK® Premium™ connector is guaranteed to meet or exceeds all material and test requirements outlined in ASTM F-2510 "Resilient Connectors Between Reinforced Concrete Manhole Structures and Corrugated High Density Polyethylene Drainage Pipes".

Extruded from compounds formulated for wastewater applications, the rubber connector is engineered to conform to the requirements of ASTM F-2510. Alternative compounds are available upon special request.

RESILIENT TEST REQUIREMENTS OF A.S.T.M. F-2510

TEST	RESULTS
Original Properties	
Tensile strength, min, psi (MPa)	1200 psi (8.3)
Elongation min, %	325
Hardness Type A durometer	40 to 60
Low-temperature hardness, Type A durometer, max increase, points	15
Compression set, max %	25
Ozone resistance	No cracks
Low Temperature Brittle Point	No Fractures -40°F (-40°C)
Tear Resistance lbf/in (kN/m), Die B	200 (34)
Accelerated Aging (Air Oven Test):	
Decrease in tensile strength, max % of original	15
Decrease in elongation, max % of original	20
Hardness, Type A durometer, max increase, points	8
After Water Immersion:	
Change in volume max %	5

Copyright ASTM INTERNATIONAL. Reprinted with permission

DIMENSIONAL DATA

Maximum Pipe O.D. Based on Manhole Diameter and Pipe Angles Using A•LOK® Premium™ Connectors.

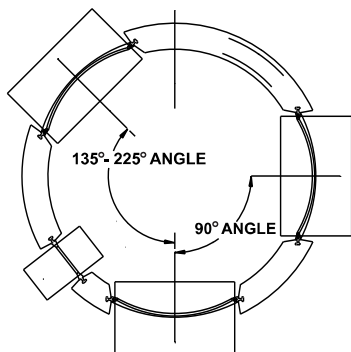

Min. distance between pipes is approx. 1/2 the smallest pipe OD

MAX. PIPE SIZE OD's

Manhole Diameter	135° - 225° Pipe Angle	90° Pipe Angle
42"	26.5"	22.0"
48"	31.5"	25.0"
60"	42.0"	32.0"
72"	52.5"	38.0"
84"	59.5"	44.0"
96"	73.5"	50.0"
108"	76.0"	56.0"
120"	87.5"	62.0"

PRODUCT SPECIFICATIONS

A flexible pipe to manhole connector shall be used whenever a pipe penetrates into a precast concrete manhole or structure. The connector shall be The A•LOK® Premium™ Connector as manufactured by A•LOK Products, Inc., Tullytown, PA or approved equal.

The design of the connector shall provide a flexible, watertight seal between the pipe and concrete structure. The connector shall assure that a seal is made between:

1. The connector and the structure wall by casting the connector integrally with the structure wall during the manufacturing process in a manner that it will not pull out during pipe coupling. The connector shall also be capable of being cast into a round structure by curving the connector in a manner that allows it to remain centrally located within the structure wall and perpendicular to the pipe. This configuration will result in no loss of seal or deflection of pipe entering a concrete structure.

2. The seal between the connector and the pipe shall be made by the compression of the connector between the outside circumference of the factory installed smooth oversleeve of a corrugated pipe or the smooth surface of a traditional pipe and the interior hole opening of the structure. The connector shall be the only component to affect the seal between the pipe and structure.

The connector shall be made from materials that conform to the physical and Section 4, "Materials and Manufacture" of ASTM F-2510 Standard Specification for Resilient Connectors Between Reinforced Concrete Manhole Structures and Corrugated High Density Polyethylene Drainage Pipes", and the overall design will meet or exceed Section 7, "Test Methods and Requirements" of ASTM F-2510. This connector shall be sized specifically for the type of pipe being used and shall be installed in accordance with the recommendations of the manufacturer.

INSTALLATION INSTRUCTIONS

Experience has shown that successful performance of this product depends on proper plant installation, as well as the backfill and the care in the field installation of the manhole or wastewater structure and connecting pipes.

STEP 1:

Confirm that the pipe surface is smooth, clean and free of foreign materials, chips, gouges and form seams due to manufacturing or handling. Slightly bevel any sharp or blunt edges caused by the cutting of the pipe.

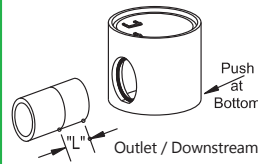

STEP 2:

Lubricate the connector and the entire section of the pipe that will be inserted into the connector. The chart below lists A-LOK's minimum lubrication length "L".

PIPE SIZE	MIN. LUBRICATION LENGTH "L"
8" - 15"	12"
16" - 18"	18"
21" & Larger	24"

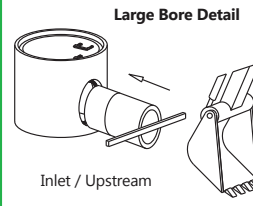

STEP 3:

Center the pipe and connector square to each other and insert the pipe into the connector using a bar or back hoe depending on the size. Once the pipe is coupled with the connector, deflect the structure or pipe to achieve the proper angle.

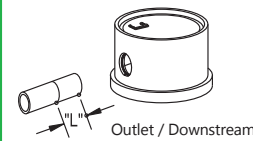

NOTE:

To find approximate subgrade, measure from the outside base of the structure to the junction of the connector and flat spot. Then add the wall thickness of the pipe plus 1/4 inch.

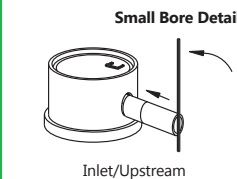

WARNING

To ensure the A-LOK® Premium™ Connector remains a flexible watertight connector, it is A-LOK Products, Inc. strong recommendation that no mortar be placed between the pipe and wall of the concrete structure. The use of mortar in this area would decrease the effectiveness of the connector to compensate for shear caused by settlement or ground movement.

CAUTION:

When installing pipe stubs for future pipeline installation, all stubs must be properly restrained to prevent any movement by means other than the A-LOK® Premium™ Connector.

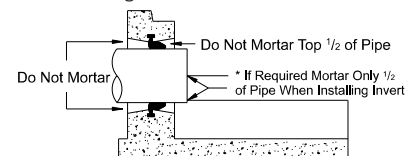

Mandrel Mounting Instructions for A-LOK Premium Connectors

A-LOK
PRODUCTS, INC.

Remove nuts and separate mandrel halves. Measure the mandrel offset dimension at 3-9 and 6-12 to be sure it matches the connector I.D. on the A-LOK Dimensional Data Sheet.

Place connector nose against the mandrel offset on the outside half with the nub of the Premium connector (**the side with the white stripe**) facing away from the center of the mandrel.

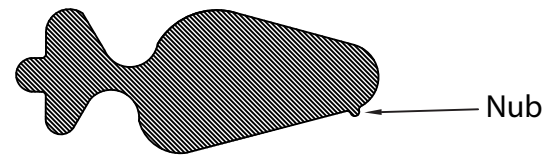
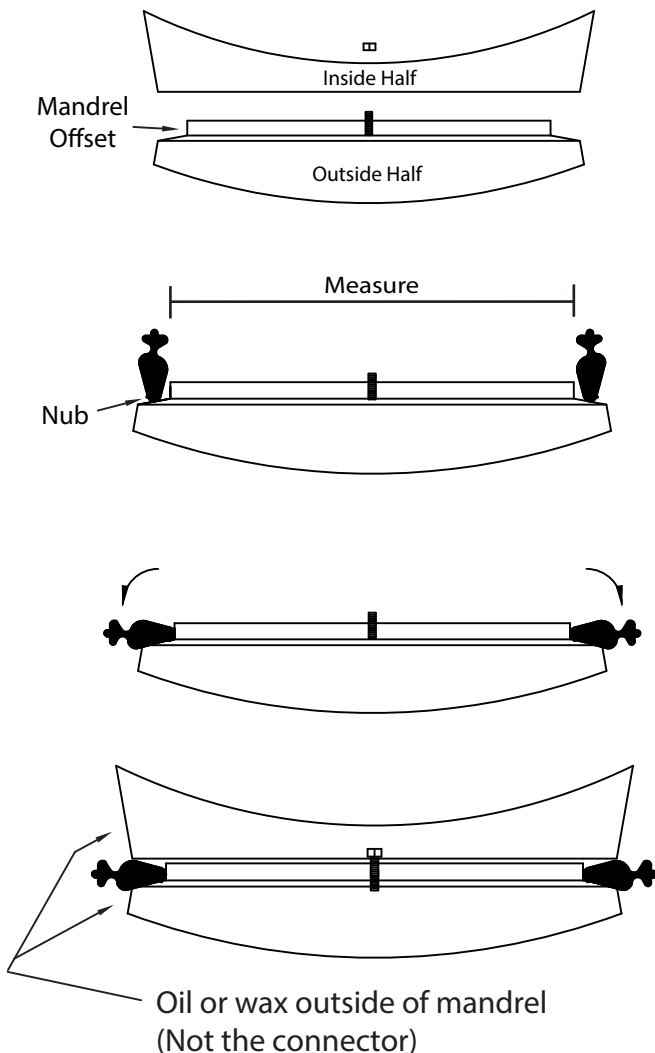

Note: A-LOK Mandrel Installation Grips are recommended to hold the connector in place which reduces set-up labor while promoting proper connector installation.

Roll connector nose against the mandrel offset on the outside half. The nub on the A-LOK Premium connector should be down against the outside mandrel half.

Set the inside half of the mandrel on top and tighten nuts.

Check all inspection holes to insure the connector is tight about the offset. The embedded "T" of the connector should be perpendicular to the centerline of the mandrel.

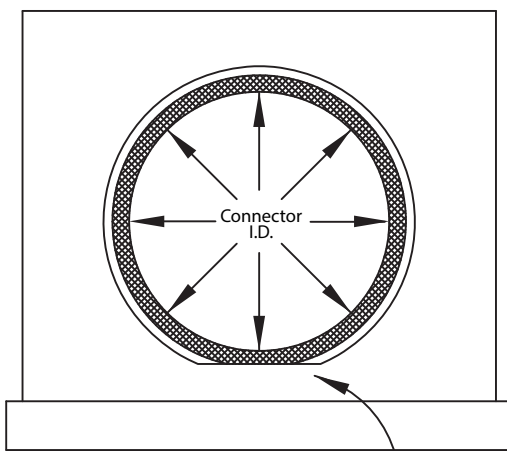

Note: Mandrels size 600 and above - Flat spot must be placed on the outside towards the bottom of the structure to ensure pipe will be centered in connector during installation.



Questions?

Web: www.a-lok.com

Email: info@a-lok.com

Ph: (215) 547-3366 | (800) 822-2565

P.O. Box 1647 697 Main Street

Tullytown, PA 19007

ConSeal™ CS-212

Polyolefin Backed Exterior Joint Wrap



Membrane Waterproofing and Exterior Joint Wrap for Precast Concrete Joints

Applications

For joints in: Box Culverts, Underground Concrete Vaults, Segmented Bridge Structures, Wastewater Structures and Arched Bridge Structures, Manholes. **Not intended for use in expansion joints or joints that move.**

Sealing Properties

- Excellent resistance to puncture, tear and abrasions.
- Aggressively bonds to concrete and metal structures.
- Provides a permanent flexible water and soil barrier.
- Will not shrink, harden or oxidize upon aging.
- Available in numerous standard sizes.
 - Standard thicknesses: 0.065" and 0.100"
 - Standard widths: 4", 6", 8", 9", 12", 24", 36" and 48"
- Custom widths and lengths available upon request.
- No priming normally necessary. When confronted with difficult installation conditions, such as wet concrete or temperatures below 40°F (4°C), priming the concrete will improve the bonding action. Consult Concrete Sealants for the proper primer to meet your application.

Specifications

ConSeal CS-212 meets ASTM E-1745, C-877, C-990 Specifications, and AASHTO M198 Type B.

Technical Data

ASTM E-1745: Standard specification for plastic water vapor retarders used in contact with soil or granular fill under concrete slabs.

Class C. Specification	Test Method	E-1745 Requirement	CS-212
Water Vapor Permeance	ASTM F-1249	0.30 perms, max.	0.045 perms, max.
Tensile Strength	ASTM E-154	13.6 lbs./ inch, min.	21.0 lbs./ inch, min.
Puncture Resistance	ASTM D-1709	475 grams, min.	864 grams, min.

ASTM C-877: Standard specification for external sealing bands for non-circular concrete sewer, storm drain and culvert pipe.

Type III, Specification	E-1745 Requirement	CS-212
Backing Bond Element	4 Mil, min. thickness	4 Mil
Butyl Rubber Adhesive	0.03 inch, min. thickness	0.065, min.

Don't Just Seal It, ConSeal It!

© 2018 Concrete Sealants, Inc.

Concrete Sealants, Inc. 9325 State Route 201 ■ Tipp City, OH 45371 ■ **Toll Free** 800.332.7325

P. 937.845.8776 **F.** 937.845.3587 ■ **www.conseal.com**



Concrete Sealants, Inc.
ISO 9001:2015 Registered

ConSeal™ CS-212

Polyolefin Backed Exterior Joint Wrap



Membrane Waterproofing and Exterior Joint Wrap for Precast Concrete Joints

Technical Data Continued

ASTM C-990: Standard specification for joints for concrete pipe, manholes and precast box sections using preformed flexible joint sealants.

Section 6, Specification	Test Method	C-990 Requirements	CS-212
Hydrocarbon blend content % by weight	ASTM D-4	50-70%	52, min.
Inert mineral filler % by weight	ASTM C-990	30% min.	45, min.
Volatile Matter % by weight	ASTM C-990	2.0 max.	1.20
Specific Gravity	ASTM C-990	1.15-1.50	1.20-1.25
Ductility, 7°F	ASTM D-113	5.0, min.	12, min.
Penetration, cone 77°F, 150 gm. 5 sec.	ASTM D-217	50-120 mm	70-80 mm
Softening point, °F	ASTM D-36	320°F, min.	335°F, min.

Limited Warranty

This information is presented in good faith, but we cannot anticipate all conditions under which this information and our products, or the products of other manufactures in combination with our products, may be used. We accept no responsibility for results obtained by the application of this information or the safety and suitability of our products, either alone or in combination with other products. Users are advised to make their own tests to determine the safety and suitability of each such product or product combinations for their own purposes. It is the **users' responsibility** to satisfy himself as to the suitability and completeness of such information for this own particular use. We sell this product without warranty, and buyers and users assume all responsibility and liability for loss or damage arising from the handling and use of this product, whether used alone or in combination with other products.

Don't Just Seal It, ConSeal It!

© 2018 Concrete Sealants, Inc.

Concrete Sealants, Inc. 9325 State Route 201 ■ Tipp City, OH 45371 ■ **Toll Free** 800.332.7325
P. 937.845.8776 **F.** 937.845.3587 ■ **www.conseal.com**



Concrete Sealants, Inc.
ISO 9001:2015 Registered

ML-10-DS-NCR

10"

CAUTION, FOR THE SAFETY OF EVERYONE:

Plastic Inserts:

This step is **not** to be installed into round, tapered plastic inserts which are smooth internally.
Compatible inserts available from American Step.

Drilling:

When this step is to be installed by drilling the installation holes; the following **must** be adhered to...

If the steel reinforcement is hit by the drill bit, start over, move the drill to another location so the drilled hole will consist of concrete **only** with **no** steel being present in the hole.

Questions:

Please call 1-800-988-STEP (7837) or email us at info@americanstep.com

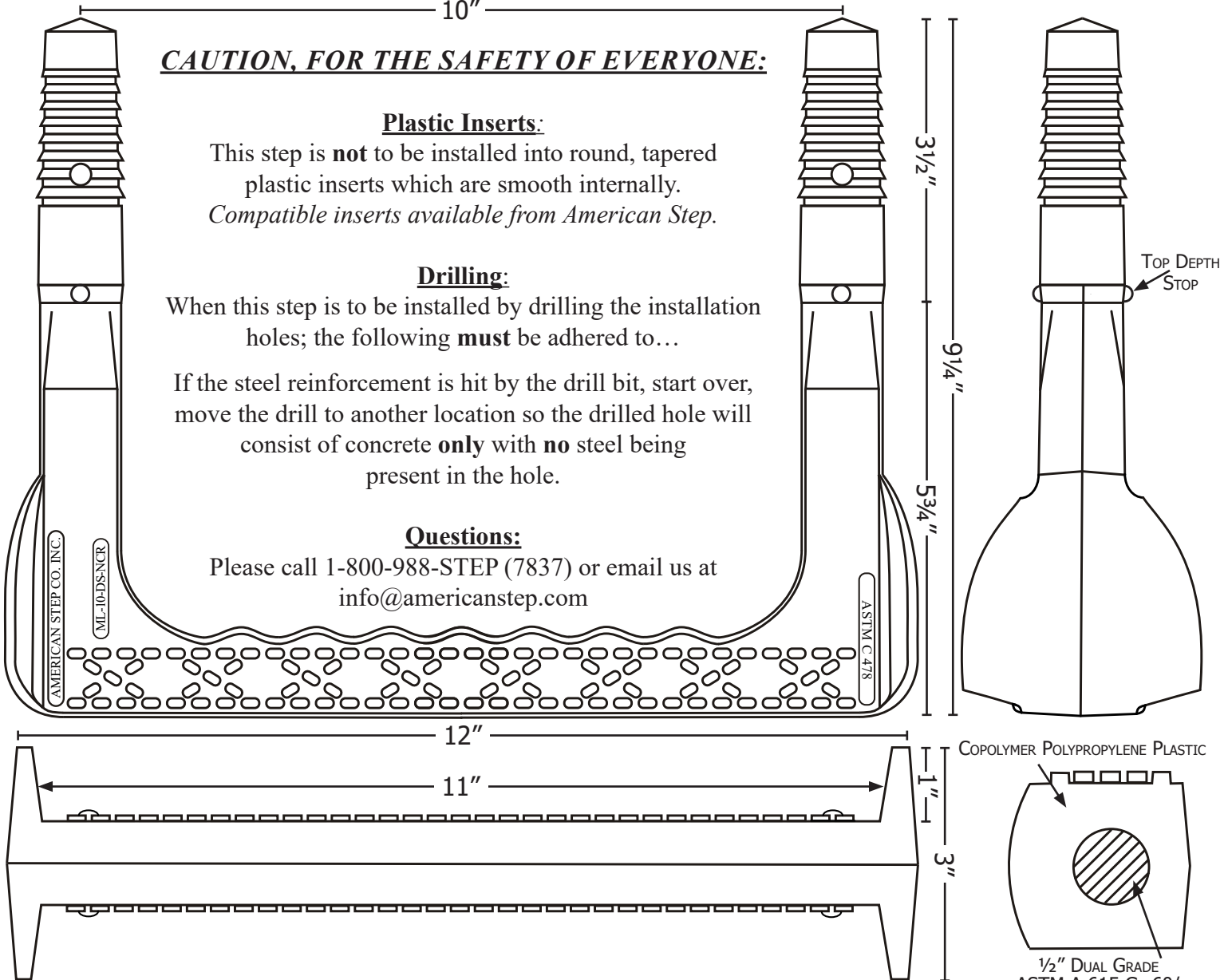

COPOLYMER POLYPROPYLENE PLASTIC

1/2" DUAL GRADE
ASTM A 615 Gr.60/
ASTM A706
STEEL REINFORCEMENT

ML-10-DS-NCR

Mechanical Lock Installation Methods
Minimum Concrete Strength **MUST** be 3,000 PSI

Preformed Holes

Two pre-formed holes on 10" centers
Holes **must** be parallel.
Diameter of holes are 1.1" tapering to 7/8" in 3 1/2" of depth.

Drilled Holes

Drill two 1" holes on 10" centers with a minimum depth of 3 3/4".
Use 1" masonry bit for drilling.
Holes **must** be parallel.

Drive step with sledge hammer until both legs are completely seated against the Top Depth Stop.

This step meets or exceeds ASTM C 478 and OSHA standards when properly installed. 6.20.2024



American Steel...American Made...American Step!

830 East Broadway • P.O. Box 137
Griffin, GA 30224

(770)467-9844 office • (770)467-8011 fax

email: info@americanstep.com

www.americanstep.com



CONSEAL™
CONCRETE SEALANTS INC.

Don't Just Seal It, ConSeal It!

ConSeal™ CS-75

Waterborne Pressure Sensitive Adhesive (PSA), Surface Primer

A Waterborne PSA Surface Primer Bonding Sealants to Concrete, Plastic and Metal Surfaces

Applications

For use on concrete, plastic and metal surfaces, ConSeal CS-75 enhances the bonding between preformed sealants and concrete surfaces aiding in the installation process. Conveniently applied at the job site, CS-75 improves adhesion of the sealant to the concrete.



Physical Properties

Description

Color:	Bright Orange
% Solids:	33% minimum
Flash Point:	200°F minimum
Weight / Gallon:	8.0 Pounds
Dry Time @ 77°F (25°C):	10 minutes
Dry Time @ 40°F (4°C):	60 minutes
Clean Up:	Soap and Water
Coverage Per Gallon:	Approx. 300 square feet on wet cast concrete. Coverage diminishes on dry cast concrete.
Appropriate Substrates:	Concrete, Plastic, and Metal.
Min. Storage Temperature:	40°F (4°C), Product should not be allowed to freeze.
Min. Application Temperature:	40°F (4°C), Remove frost from concrete surface before applying.
Surface When Dry:	Tacky

DO NOT SUBJECT CS-75 TO FREEZING TEMPERATURES

Primer Application Procedures

The following procedures should be followed for optimum primer performance.

- Clean the surface with a brush and remove any dirt, debris, flashing, or concrete high points, which could keep ConSeal primer from adhering to the concrete.
 - Joint primer CS-75, is to be applied to improve sealant adhesion. CS-75 is a waterborne primer that dries tacky and must be applied at the time of the installation.
 - Allow the primer to dry before placing sealant. CS-75 will be tacky within 15-20 minutes (77°F at 50% relative humidity).
- Applying CS-75: ConSeal CS-75 is an adhesive primer that dries tacky. It is waterborne and does not contain volatile or flammable components. Open the pail and apply the product using a standard paintbrush or paint roller.

Limited Warranty

This information is presented in good faith, but we cannot anticipate all conditions under which this information and our products, or the products of other manufactures in combination with our products, may be used. We accept no responsibility for results obtained by the application of this information or the safety and suitability of our products, either alone or in combination with other products. Users are advised to make their own tests to determine the safety and suitability of each such product or product combinations for their own purposes. It is the users' responsibility to satisfy himself as to the suitability and completeness of such information for this own particular use. We sell this product without warranty, and buyers and users assume all responsibility and liability for loss or damage arising from the handling and use of this product, whether used alone or in combination with other products.

Version: 12-Feb-20

© 2020 Concrete Sealants, Inc.

CONCRETE SEALANTS INC. ■ 9325 State Route 201 ■ Tipp City, OH 45371, USA ■ www.CONSEAL.com
Toll Free (USA): 800.332.7325 ■ Phone: +1.937.845.8776 ■ Fax: +1.937.845.3587



Concrete Sealants, Inc.
ISO 9001:2015 Registered