

Job Name: 25-3292 Arbor View Sec. 2
 Job Location: Eminence, KY
 Contractor: Core & Main LP (Lou)

Plant: Beaver Dam

Tech: C.Russ

10/13/2025 1:47:53 PM

PC: J.Jarvis



Structure ID: SSMH F2

P1 MH048BA24

MH BASE T/n

- P3) 24" - CASTING HEIGHT - 7"
- P2) 48" - ECC CONE w/ 24" HOLE F/G - 30"
- P1) 48" - MH BASE T/n - 24"
- 1) 48" - MH INVERT CHANNEL - FULL HEIGHT
- 1) JOINT WRAP - 0.065"x6"x50' CONSEAL CS212
- 1) JOINT WRAP PRIMER - CONSEAL CS-75 (1 gal.)
- 1) CASTING - HOE MC-315 F/C Sanitary
- 1) 48" - DBL 1"x14.5' Butyl (2x)
- 2) A-Lok - 0285

0 lb
 2050 lb
 2944 lb
 1440 lb
 0 lb
 0 lb
 258 lb
 0 lb
 2 lb

 Structure Total: 6694 lb

Structure Notes:

1. PER ASTM C478 SPECIFICATIONS.
2. CONCRETE = 4,000 PSI AT 28 DAYS.
3. MC-315 "SANITARY" BY ICAST
4. REINFORCING PER ASTM A615 (GRADE 60).
 - CONE (As .12)
 - RISER/WALLS (As .12)
 - FLOOR (As .31) #5 BARS AT 12" C.C.E.W.
5. NO STEPS

Rim: 913.9' Rim to Invert: 5.07' Slack: 1.84" Sump: 2" Step Position: 270°

Position	Elev	Angle	Ext. (cw)	Pipe	Pipe OD	Connector	Hole	Horz Size	Up ()	Offset
Invert 1	908.83'	0°	0"	8" PVC SDR35	8.5"	A-Lok 0285	9.75"	9.818"	1.125"	0"
Invert 2	908.86'	97°	49.096"	8" PVC SDR35	8.5"	A-Lok 0285	9.75"	9.818"	1.485"	0"
Invert 3										
Invert 4										
Invert 5										
Invert 6										
Invert 7										
Invert 8										

RIGHT-SIDE UP VIEW (int. dimensions)

UPSIDE-DOWN VIEW (int. dimenions)

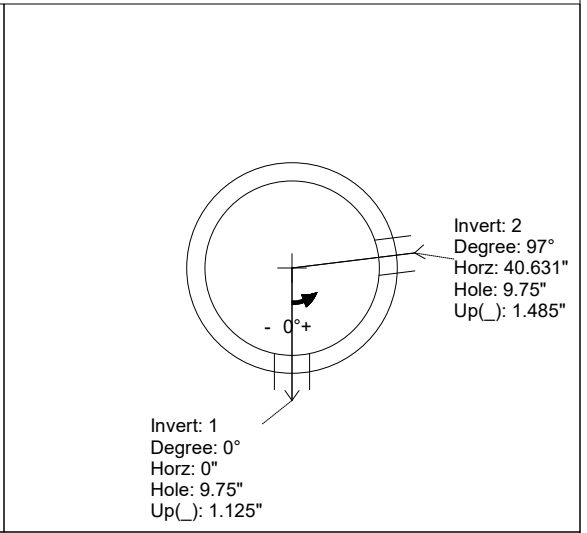
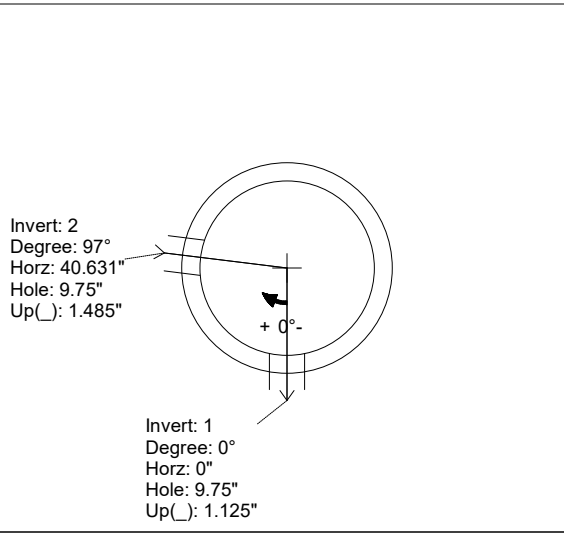
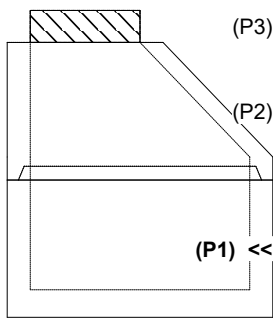

INSIDE WALL DIMENSIONS

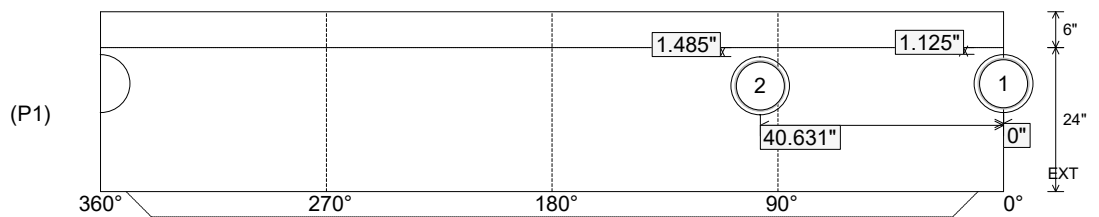

Coating (Int):
 Coating (Ext):

Seam Up: Tongue
 Seam Dn: n/a

Wall Thickness: 5"
 Floor Height: 6"

Height (Int): 24"
 Height (Ext): 30"

Weight (Net): 2944 lb
 Volume (Net): 0.75cu.yd