

**Structure ID: SSMH F2**

**P1 MH048BA24**

**MH BASE T/n**

- |   |  |      |  |         |  |         |  |         |  |      |  |      |  |        |  |      |  |      |  |       |  |                  |         |
|---|--|------|--|---------|--|---------|--|---------|--|------|--|------|--|--------|--|------|--|------|--|-------|--|------------------|---------|
| P3) 24" - CASTING HEIGHT - 7"<br>P2) 48" - ECC CONE w/ 24" HOLE F/G - 30"<br>P1) 48" - MH BASE T/n - 24"<br>1) 48" - MH INVERT CHANNEL - FULL HEIGHT<br>1) JOINT WRAP - 0.065"x6"x50' CONSEAL CS212<br>1) JOINT WRAP PRIMER - CONSEAL CS-75 (1 gal.)<br>1) CASTING - HOE MC-315 F/C Sanitary<br>1) 48" - DBL 1"x14.5' Butyl (2x)<br>2) A-Lok - 0285 | <table style="width:100%; border-collapse: collapse;"> <tr><td style="text-align: right;">0 lb</td><td></td></tr> <tr><td style="text-align: right;">2050 lb</td><td></td></tr> <tr><td style="text-align: right;">2944 lb</td><td></td></tr> <tr><td style="text-align: right;">1440 lb</td><td></td></tr> <tr><td style="text-align: right;">0 lb</td><td></td></tr> <tr><td style="text-align: right;">0 lb</td><td></td></tr> <tr><td style="text-align: right;">258 lb</td><td></td></tr> <tr><td style="text-align: right;">0 lb</td><td></td></tr> <tr><td style="text-align: right;">2 lb</td><td></td></tr> <tr><td style="text-align: right;">-----</td><td></td></tr> <tr><td style="text-align: right;">Structure Total:</td><td style="text-align: right;">6694 lb</td></tr> </table> | 0 lb |  | 2050 lb |  | 2944 lb |  | 1440 lb |  | 0 lb |  | 0 lb |  | 258 lb |  | 0 lb |  | 2 lb |  | ----- |  | Structure Total: | 6694 lb |
| 0 lb  |  |      |  |         |  |         |  |         |  |      |  |      |  |        |  |      |  |      |  |       |  |                  |         |
| 2050 lb   |  |      |  |         |  |         |  |         |  |      |  |      |  |        |  |      |  |      |  |       |  |                  |         |
| 2944 lb   |  |      |  |         |  |         |  |         |  |      |  |      |  |        |  |      |  |      |  |       |  |                  |         |
| 1440 lb   |  |      |  |         |  |         |  |         |  |      |  |      |  |        |  |      |  |      |  |       |  |                  |         |
| 0 lb  |  |      |  |         |  |         |  |         |  |      |  |      |  |        |  |      |  |      |  |       |  |                  |         |
| 0 lb  |  |      |  |         |  |         |  |         |  |      |  |      |  |        |  |      |  |      |  |       |  |                  |         |
| 258 lb  |  |      |  |         |  |         |  |         |  |      |  |      |  |        |  |      |  |      |  |       |  |                  |         |
| 0 lb  |  |      |  |         |  |         |  |         |  |      |  |      |  |        |  |      |  |      |  |       |  |                  |         |
| 2 lb  |  |      |  |         |  |         |  |         |  |      |  |      |  |        |  |      |  |      |  |       |  |                  |         |
| -----   |  |      |  |         |  |         |  |         |  |      |  |      |  |        |  |      |  |      |  |       |  |                  |         |
| Structure Total:  | 6694 lb  |      |  |         |  |         |  |         |  |      |  |      |  |        |  |      |  |      |  |       |  |                  |         |

- Structure Notes:**
1. PER ASTM C478 SPECIFICATIONS.
  2. CONCRETE = 4,000 PSI AT 28 DAYS.
  3. MC-315 "SANITARY" BY ICAST
  4. REINFORCING PER ASTM A615 (GRADE 60).  
 - CONE (As .12)  
 - RISER/WALLS (As .12)  
 - FLOOR (As .31) #5 BARS AT 12" C.C.E.W.
  5. NO STEPS

INVERT

Rim: 913.9'    Rim to Invert: 5.07'    Slack: 1.84"    Sump: 2"    Step Position: 270°

Position	Elev	Angle	Ext. (cw)	Pipe	Pipe OD	Connector	Hole	Horz Size	Up ( )	Offset
Invert 1	908.83'	0°	0"	8" PVC SDR35	8.5"	A-Lok 0285	9.75"	9.818"	1.125"	0"
Invert 2	908.86'	97°	49.096"	8" PVC SDR35	8.5"	A-Lok 0285	9.75"	9.818"	1.485"	0"
Invert 3										
Invert 4										
Invert 5										
Invert 6										
Invert 7										
Invert 8										

RIGHT-SIDE UP VIEW (int. dimensions)

UPSIDE-DOWN VIEW (int. dimenions)

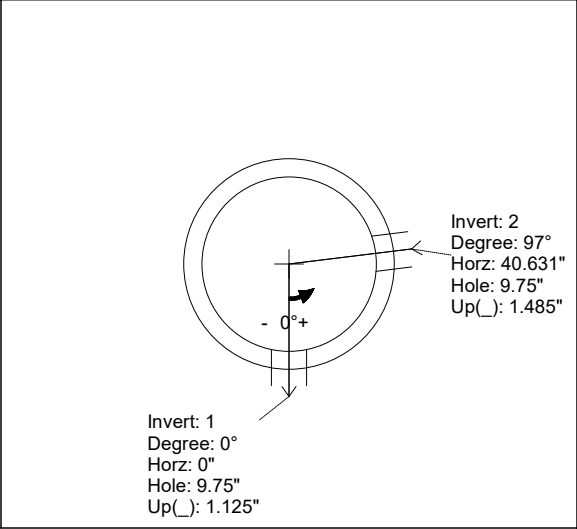
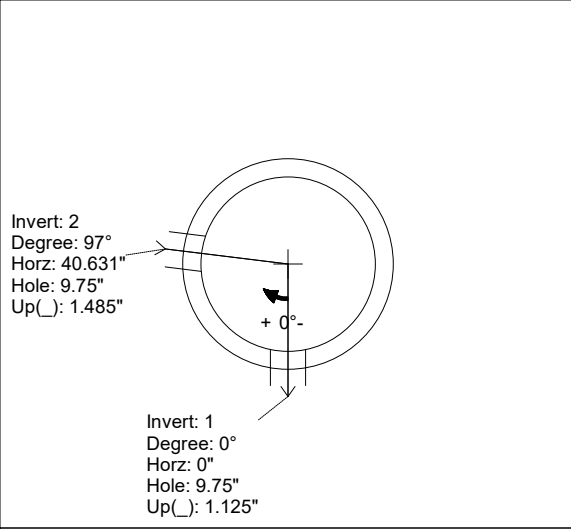
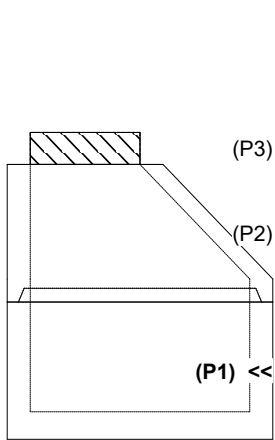

INSIDE WALL DIMENSIONS

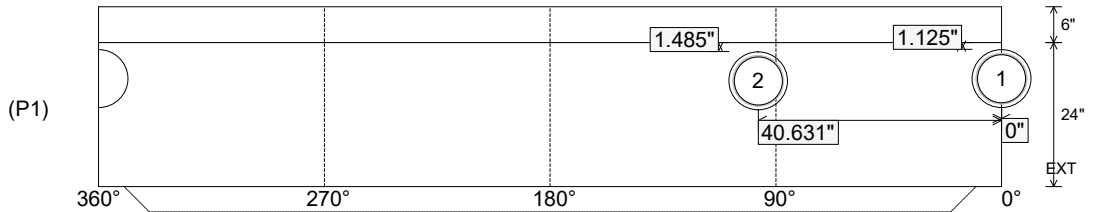

Coating (Int): Coating (Ext):	Seam Up: Tongue Seam Dn: n/a	Wall Thickness: 5" Floor Height: 6"	Height (Int): 24" Height (Ext): 30"	Weight (Net): 2944 lb Volume (Net): 0.75cu.yd
----------------------------------	---------------------------------	--	--	--