

Job Name: 25-3292 Arbor View Sec. 2  
 Job Location: Eminence, KY  
 Contractor: Core & Main LP (Lou)

Plant: Beaver Dam  
 10/13/2025 1:47:16 PM

Tech: C.Russ  
 PC: J.Jarvis

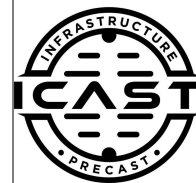

**Structure ID: CBI-C3**

**P1 MH048BA36**

**MH BASE T/n**

- P3) 24" x 36" - CASTING HEIGHT - 6"
- P2) 48" - MH FLAT TOP w/24"x36" Hole F/G - 12"
- P1) 48" - MH BASE T/n - 36"
- 1) CASTING - HOE 525 LV SET (F/G/H)
- 1) 48" - SGL 1"x14.5' Butyl (2x)
- 2) Hole - 24
- 3) MH Step ML-10-TDS-NCR - 10"

0 lb  
 1300 lb  
 3451 lb  
 442 lb  
 0 lb  
 0 lb  
 0 lb  
 -----  
 Structure Total: 5193 lb

- Structure Notes:**
1. PER ASTM C478 SPECIFICATIONS.
  2. CONCRETE = 4,000 PSI AT 28 DAYS.
  3. HOE 525 BY ICAST.
  4. REINFORCING PER ASTM A615 (GRADE 60).
    - TOP SLAB (As .62) #5 BARS AT 6" C.C.E.W..
    - RISER/WALLS (As .12)
    - FLOOR (As .31) #5 BARS AT 12" C.C.E.W.

Rim: 897.76' Rim to Invert: 4.66' Slack: 1.92" Sump: 0" Step Position: 270°

Position	Elev	Angle	Ext. (cw)	Pipe	Pipe OD	Connector	Hole	Horz Size	Up (↓)	Offset
Invert 1	893.1'	0°	0"	18" HDPE	21.2"	Hole 24	24"	25.133"	-1.6"	0"
Invert 2	893.1'	164°	83.008"	18" HDPE	21.2"	Hole 24	24"	25.133"	-1.6"	0"
Invert 3										
Invert 4										
Invert 5										
Invert 6										
Invert 7										
Invert 8										

RIGHT-SIDE UP VIEW (int. dimensions)

UPSIDE-DOWN VIEW (int. dimensions)

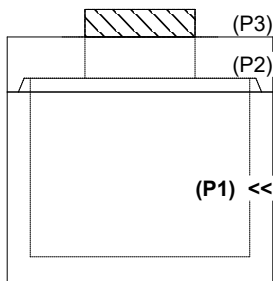
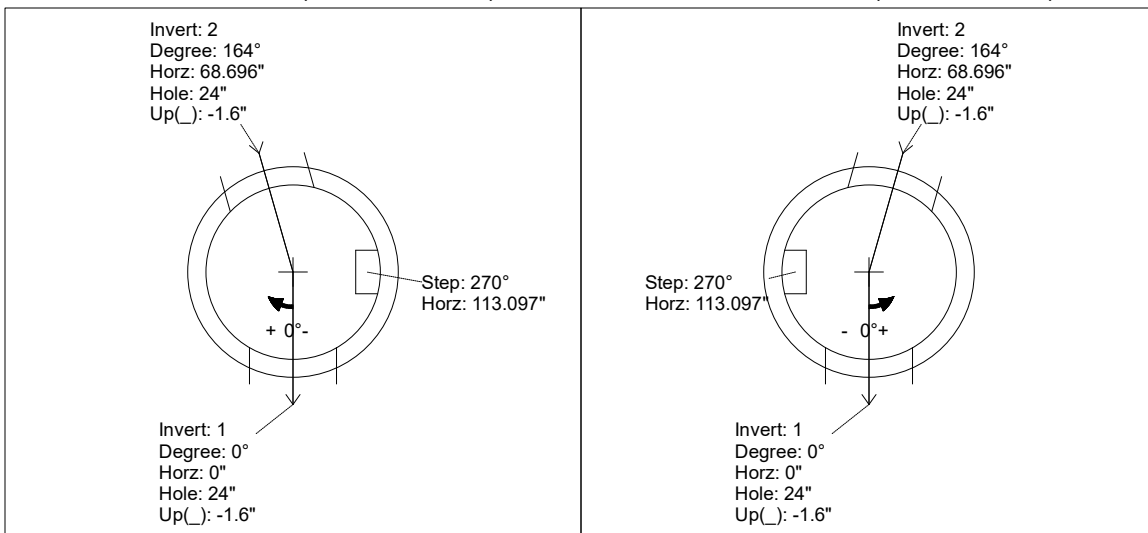

INSIDE WALL DIMENSIONS

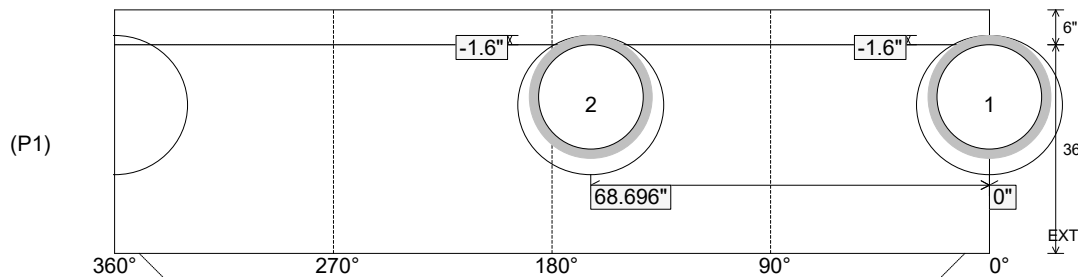

Coating (Int):  
 Coating (Ext):

Seam Up: Tongue  
 Seam Dn: n/a

Wall Thickness: 5"  
 Floor Height: 6"

Height (Int): 36"  
 Height (Ext): 42"

Weight (Net): 3451 lb  
 Volume (Net): 0.88cu.yd