

Structure ID: CBI-C2

P1 BX2436-08BVF

BOX BASE 8inW, 8inF, Variable Ht F/n

P2) 24" x 36" - CASTING HEIGHT - 6"
 P1) 24" x 36" - BOX BASE 8inW, 8inF, Variable Ht F/n - 33"
 1) CASTING - HOE 525 LV SET (F/G/H)
 1) 24" x 36" - SGL 1"x14.5' Butyl
 2) Hole - 24"

0 lb
 4232 lb
 442 lb
 0 lb
 0 lb

 Structure Total: 4674 lb

Structure Notes:
 1. PER ASTM C913 SPECIFICATIONS.
 2. CONCRETE = 4,000 PSI AT 28 DAYS.
 3. NO INVERT CHANNEL.
 4. HOE 525 BY ICAST
 5. REINFORCING PER ASTM A615 (GRADE 60).
 - WALLS (As .12) #5 BARS AT 12" C.C.E.W.
 - FLOOR (As .12) #5 BARS AT 12" C.C.E.W.

Rim: 908.83' Rim to Invert: 3.31' Slack: 0.72" Sump: 0" Step Position:

Position	Elev	Angle	Ext. (cw)	Pipe	Pipe OD	Connector	Hole	Horz Size	Up ()	Offset
Invert 1	905.52'	180°	20"	18" HDPE	21.2"	Hole 24	24"	24"	-1.6"	0"
Invert 2	905.52'	270°	26"	18" HDPE	21.2"	Hole 24	24"	24"	-1.6"	0"
Invert 3										
Invert 4										
Invert 5										
Invert 6										
Invert 7										
Invert 8										

RIGHT-SIDE UP VIEW (int. dimensions)

UPSIDE-DOWN VIEW (int. dimensions)

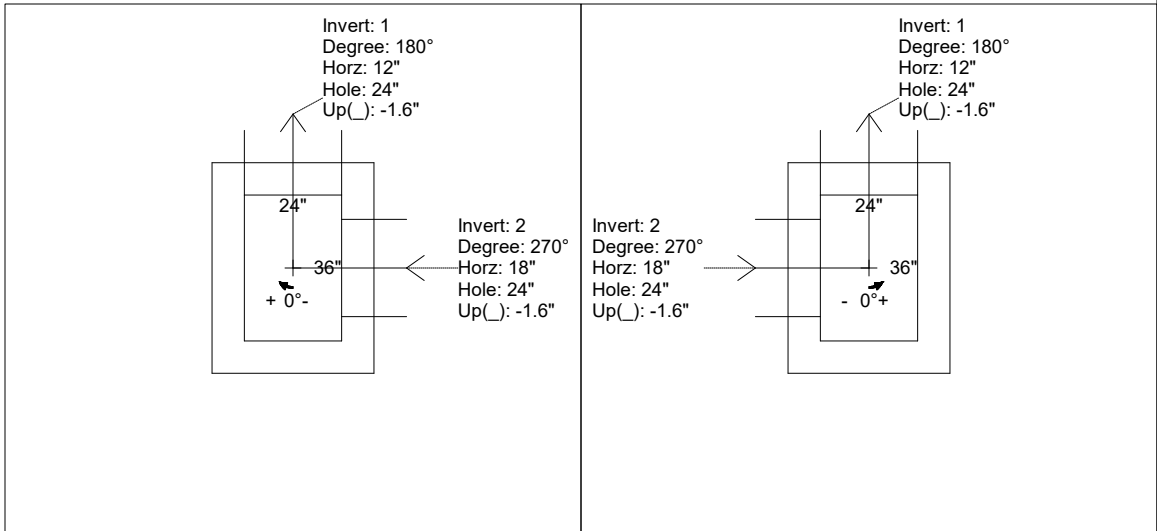
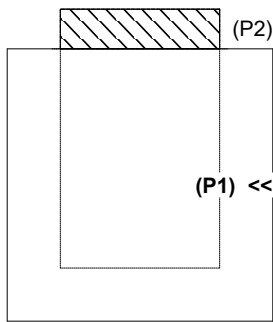

INSIDE WALL DIMENSIONS

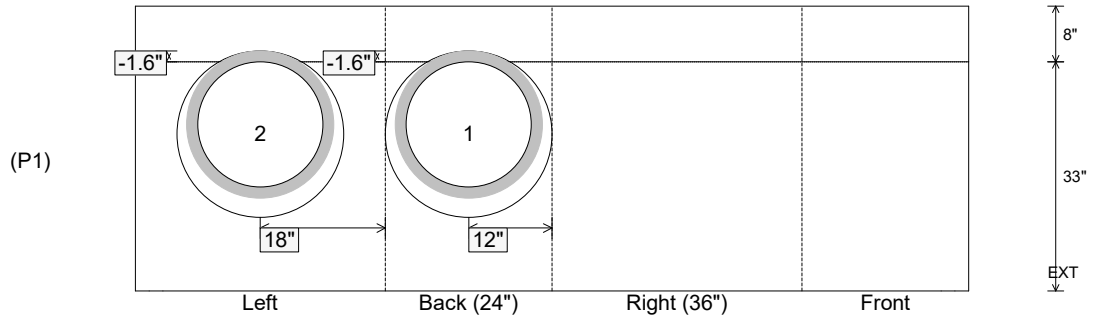

Coating (Int): Coating (Ext):	Seam Up: Flat Seam Dn: n/a	Wall Thickness: 8" Floor Height: 8"	Height (Int): 33" Height (Ext): 41"	Weight (Net): 4232 lb Volume (Net): 1.08cu.yd
----------------------------------	-------------------------------	--	--	--