

Job Name: 25-3292 Arbor View Sec. 2
 Job Location: Eminence, KY
 Contractor: Core & Main LP (Lou)

Plant: Beaver Dam

Tech: C.Russ

10/13/2025 1:45:30 PM

PC: J.Jarvis



Structure ID: YI-A3

P1 MH048BAVF

MH BASE Custom Ht T/n

- P3) 24" x 36" - CASTING HEIGHT - 4"
- P2) 48" - MH FLAT TOP w/24"x36" Hole F/G - 12"
- P1) 48" - MH BASE Custom Ht T/n - 69"
- 1) CASTING - HOE 518 F/G
- 1) 48" - SGL 1"x14.5' Butyl (2x)
- 2) Hole - 24
- 6) MH Step ML-10-TDS-NCR - 10"

0 lb
 1300 lb
 5756 lb
 354 lb
 0 lb
 0 lb
 0 lb

 Structure Total: 7410 lb

Structure Notes:

1. PER ASTM C478 SPECIFICATIONS.
2. CONCRETE = 4,000 PSI AT 28 DAYS.
3. HOE 518 F/G BY ICAST
4. REINFORCING PER ASTM A615 (GRADE 60).
 - TOP SLAB (As .62) #5 BARS AT 6" C.C.E.W..
 - RISER/WALLS (As .12)
 - FLOOR (As .31) #5 BARS AT 12" C.C.E.W.

Rim: 897.3' Rim to Invert: 7.11' Slack: 0.32" Sump: 0" Step Position: 90

Position	Elev	Angle	Ext. (cw)	Pipe	Pipe OD	Connector	Hole	Horz Size	Up (↓)	Offset
Invert 1	890.19'	0°	0"	18" HDPE	21.2"	Hole 24	24"	25.133"	-1.6"	0"
Invert 2	893.51'	180°	91.106"	18" HDPE	21.2"	Hole 24	24"	25.133"	38.24"	0"
Invert 3										
Invert 4										
Invert 5										
Invert 6										
Invert 7										
Invert 8										

RIGHT-SIDE UP VIEW (int. dimensions)

UPSIDE-DOWN VIEW (int. dimensions)

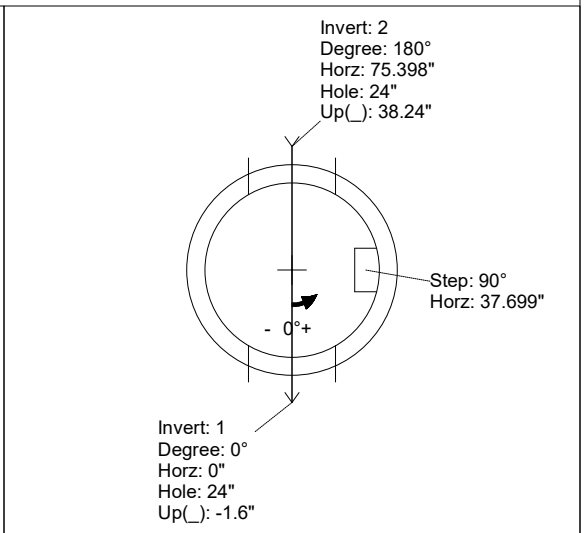
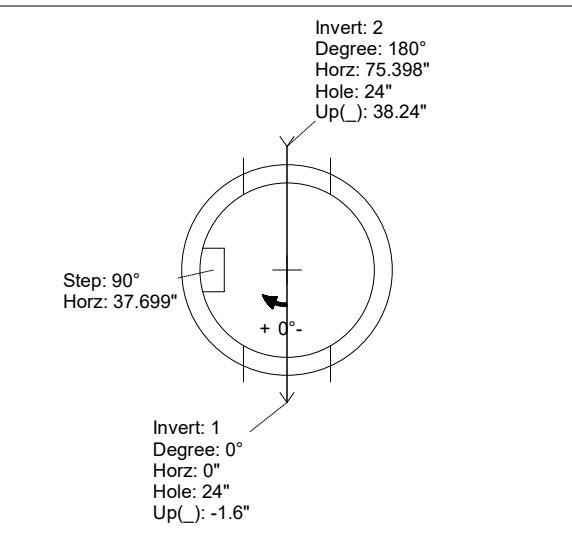
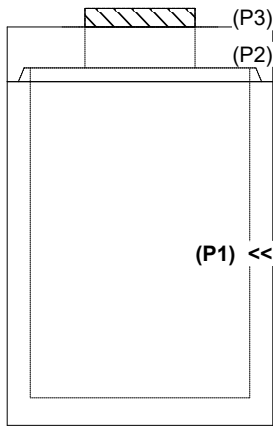

INSIDE WALL DIMENSIONS

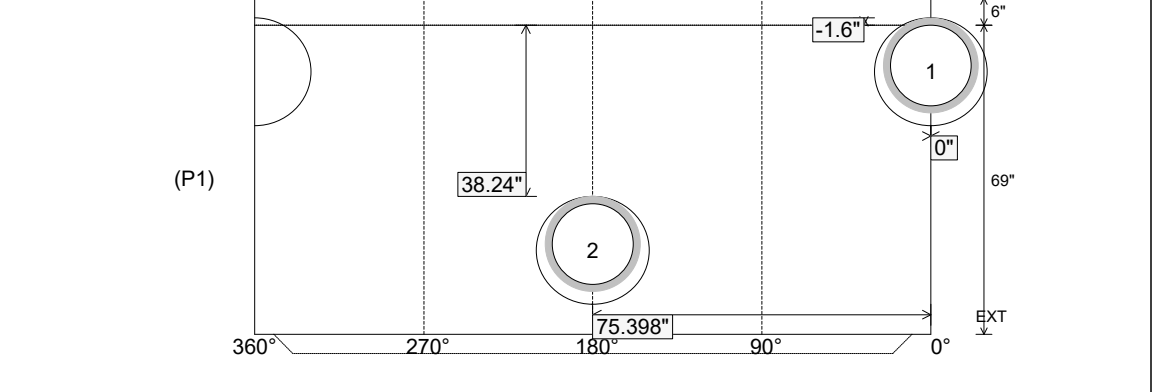

Coating (Int):
 Coating (Ext):

Seam Up: Tongue
 Seam Dn: n/a

Wall Thickness: 5"
 Floor Height: 6"

Height (Int): 69"
 Height (Ext): 75"

Weight (Net): 5756 lb
 Volume (Net): 1.47cu.yd