

Structure ID: SSMH 2

P1 MH048BA30X

MH BASE w/XYPEX T/n

P4) 24" - CASTING HEIGHT - 7" P3) 24" - XYPEX GRADE RING F/F - 4" P2) 48" - CON XYPEX CONE w/24" HOLE F/G - 36" P1) 48" - MH BASE w/XYPEX T/n - 30" 1) 48" - MH INVERT CHANNEL w/XYPEX - FULL HEIGHT 1) JOINT WRAP - 0.065"x6"x50' CONSEAL CS212 1) JOINT WRAP PRIMER - CONSEAL CS-75 (1 gal.) 1) ADMIXTURE CONBLOCK CDA RED 1) 48" - DBL 1"x14.5' Butyl (2x) 3) PSX - 12-08 NYLO	0 lb 270 lb 2251 lb 3282 lb 1440 lb 0 lb 0 lb 0 lb 0 lb 24 lb <hr style="width: 50px; margin-left: auto; margin-right: 0;"/> 7267 lb	Structure Notes: 1. PER ASTM C913 SPECIFICATIONS. 2. CONCRETE = 4,000 PSI AT 28 DAYS. 3. NO INVERT CHANNEL. 4. CASTING BY OTHERS REINFORCING PER ASTM A615 (GRADE 60). - WALLS (As .31) #5 BARS AT 12" C.C.E.W. - FLOOR (As .31) #5 BARS AT 12" C.C.E.W.
--	--	---

Structure Total: 7267 lb

Rim: 608.21' Rim to Invert: 6.34' Slack: 1.08" Sump: 2" Step Position: 180

Position	Elev	Angle	Ext. (cw)	Pipe	Pipe OD	Connector	Hole	Horz Size	Up ()	Offset
Invert 1	601.87'	0°	0"	8" PVC SDR35	8.5"	PSX 12-08 NYLO	12"	12.129"	0"	0"
Invert 2	602.11'	90°	45.5"	8" PVC SDR35	8.5"	PSX 12-08 NYLO	12"	12.129"	2.875"	0"
Invert 3	602.26'	270°	136.625"	8" PVC SDR35	8.5"	PSX 12-08 NYLO	12"	12.129"	4.625"	0"
Invert 4										
Invert 5										
Invert 6										
Invert 7										
Invert 8										

RIGHT-SIDE UP VIEW (int. dimensions)

UPSIDE-DOWN VIEW (int. dimensions)

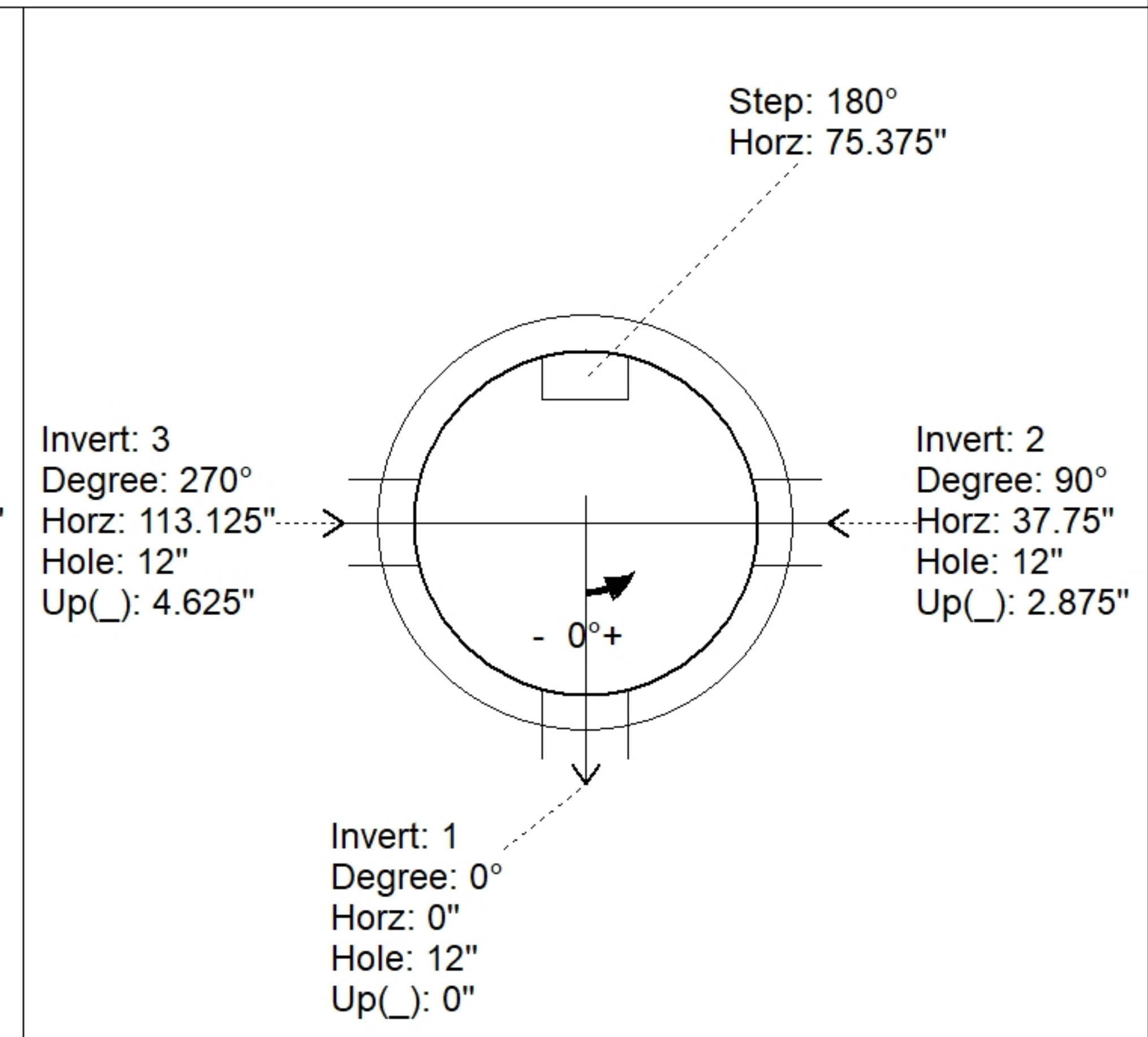
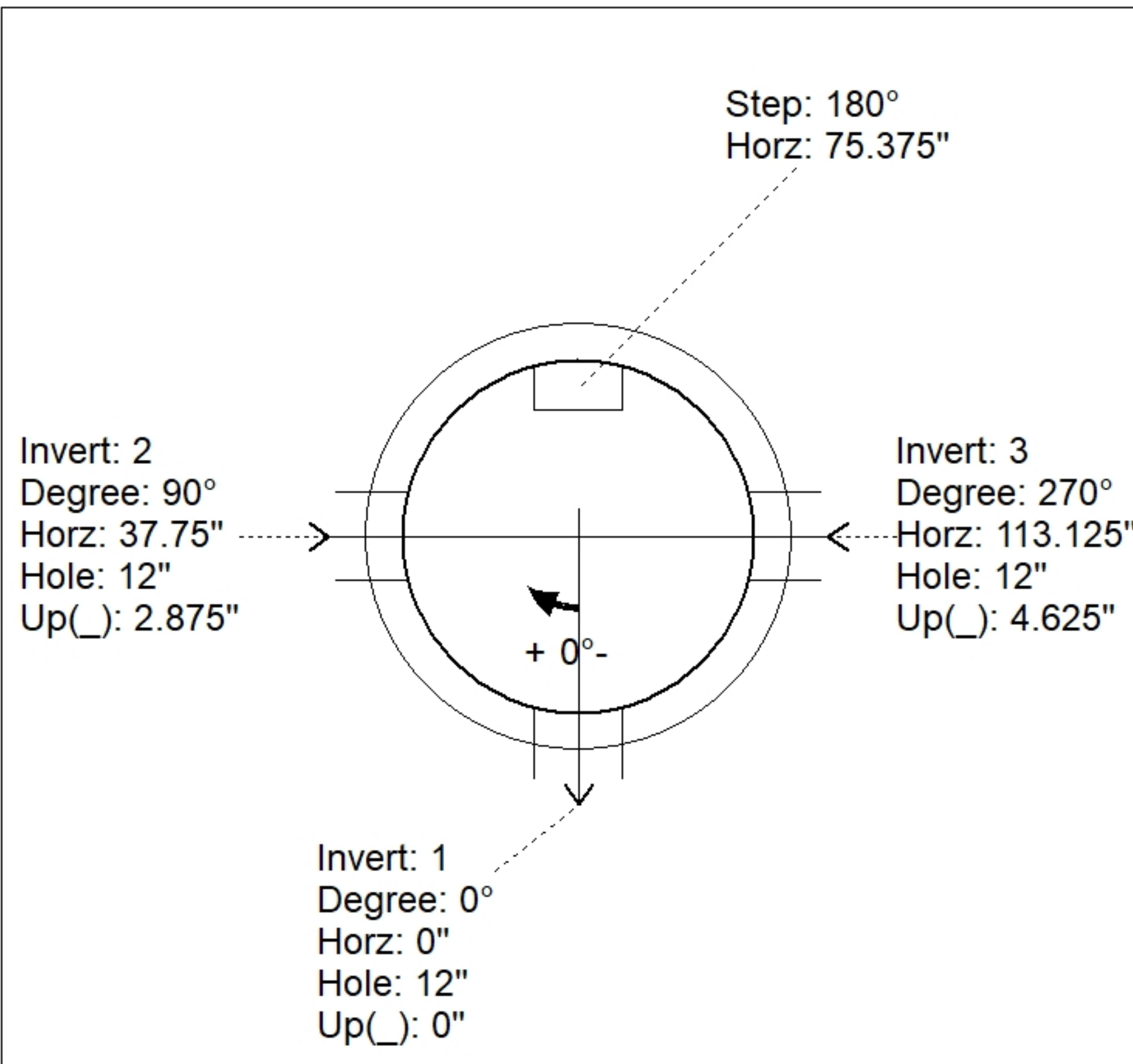
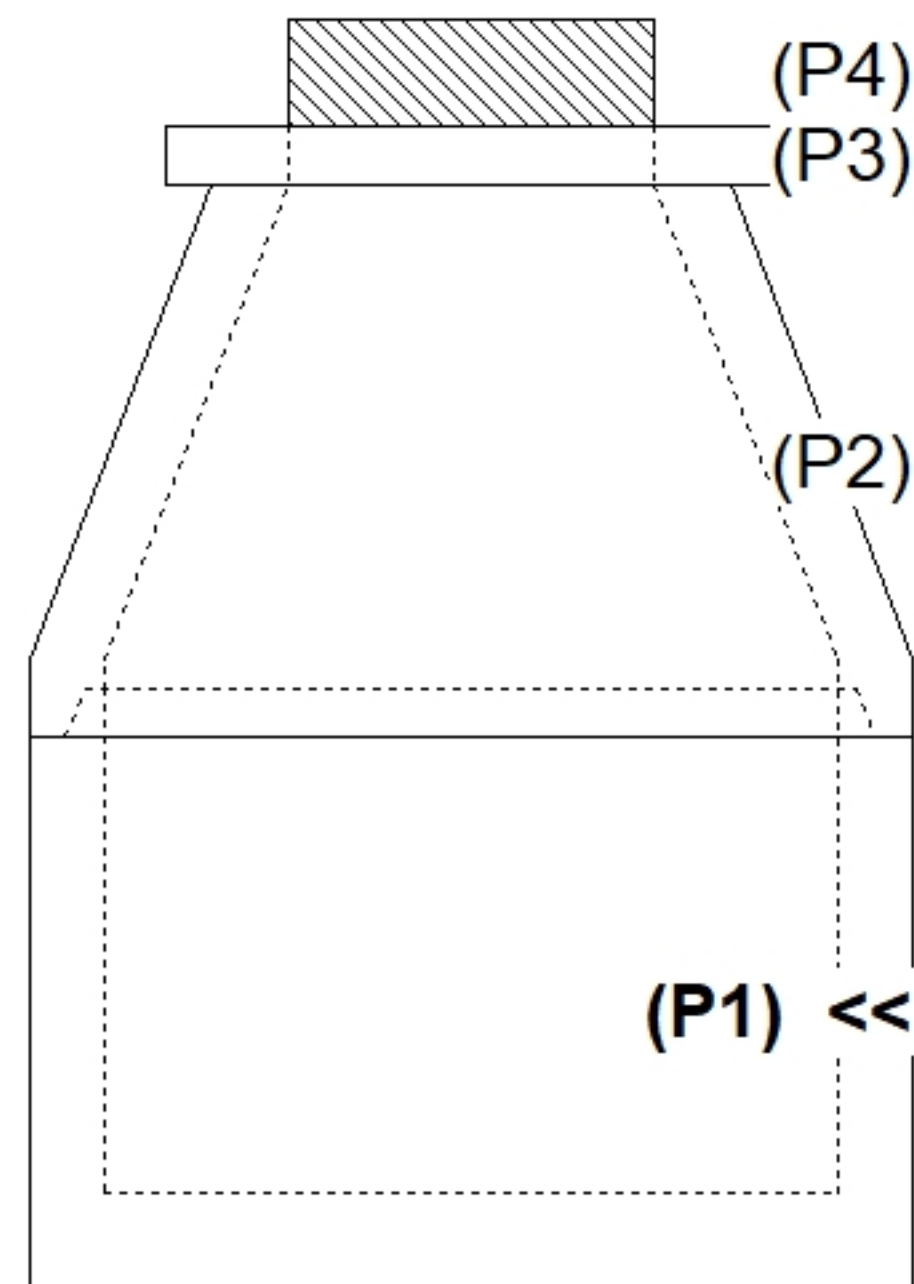

INSIDE WALL DIMENSIONS

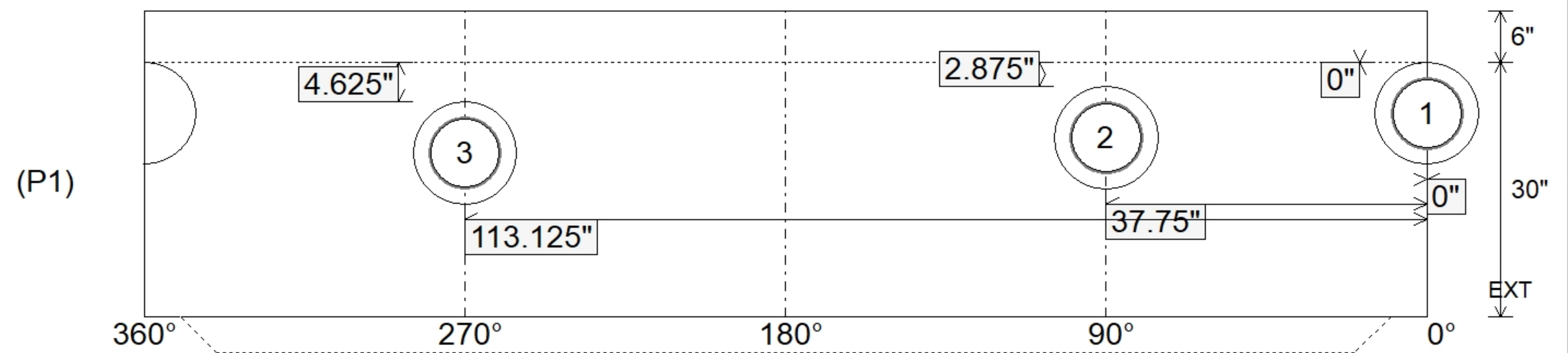

Coating (Int): Coating (Ext):	Seam Up: Tongue Seam Dn: n/a	Wall Thickness: 5" Floor Height: 6"	Height (Int): 30" Height (Ext): 36"	Weight (Net): 3282 lb Volume (Net): 0.84cu.yd
----------------------------------	---------------------------------	--	--	--

Job Name: 25-2860 Grace Park
 Job Location: Nashville, TN
 Contractor: Elite Building Group Inc.

Plant: Beaver Dam
 10/14/2025 3:21:14 PM

Tech: C.Russ
 PC: A.Chambers



Structure ID: SSMH 2

P1A MH048BA30X

MH BASE w/XYPEX T/n

P4) 24" - CASTING HEIGHT - 7"	0 lb
P3) 24" - XYPEX GRADE RING F/F - 4"	270 lb
P2) 48" - CON XYPEX CONE w/24" HOLE F/G - 36"	2251 lb
P1) 48" - MH BASE w/XYPEX T/n - 30"	3282 lb
1) 48" - MH INVERT CHANNEL w/XYPEX - FULL HEIGHT	1440 lb
1) JOINT WRAP - 0.065"x6"x50' CONSEAL CS212	0 lb
1) JOINT WRAP PRIMER - CONSEAL CS-75 (1 gal.)	0 lb
1) ADMIXTURE CONBLOCK CDA RED	0 lb
1) 48" - DBL 1"x14.5' Butyl (2x)	0 lb
3) PSX - 12-08 NYLO	24 lb
Structure Total:	7267 lb

Structure Notes:
 1. PER ASTM C913 SPECIFICATIONS.
 2. CONCRETE = 4,000 PSI AT 28 DAYS.
 3. NO INVERT CHANNEL.
 4. CASTING BY OTHERS

REINFORCING PER ASTM A615 (GRADE 60).
 - WALLS (As .31) #5 BARS AT 12" C.C.E.W.
 - FLOOR (As .31) #5 BARS AT 12" C.C.E.W.

Rim: 608.21' Rim to Invert: 6.34' Slack: 1.08" Sump: 2" Step Position: 180

Position	Elev	Angle	Ext. (cw)	Pipe	Pipe OD	Connector	Hole	Horz Size	Up ()	Offset
Invert 1	601.87'	0°	0"	8" PVC SDR35	8.5"	PSX 12-08 NYLO	12"	12.129"	0"	0"
Invert 2	602.11'	90°	45.5"	8" PVC SDR35	8.5"	PSX 12-08 NYLO	12"	12.129"	2.875"	0"
Invert 3	602.26'	270°	136.625"	8" PVC SDR35	8.5"	PSX 12-08 NYLO	12"	12.129"	4.625"	0"
Invert 4										
Invert 5										
Invert 6										
Invert 7										
Invert 8										

RIGHT-SIDE UP VIEW (int. dimensions)

UPSIDE-DOWN VIEW (int. dimensions)

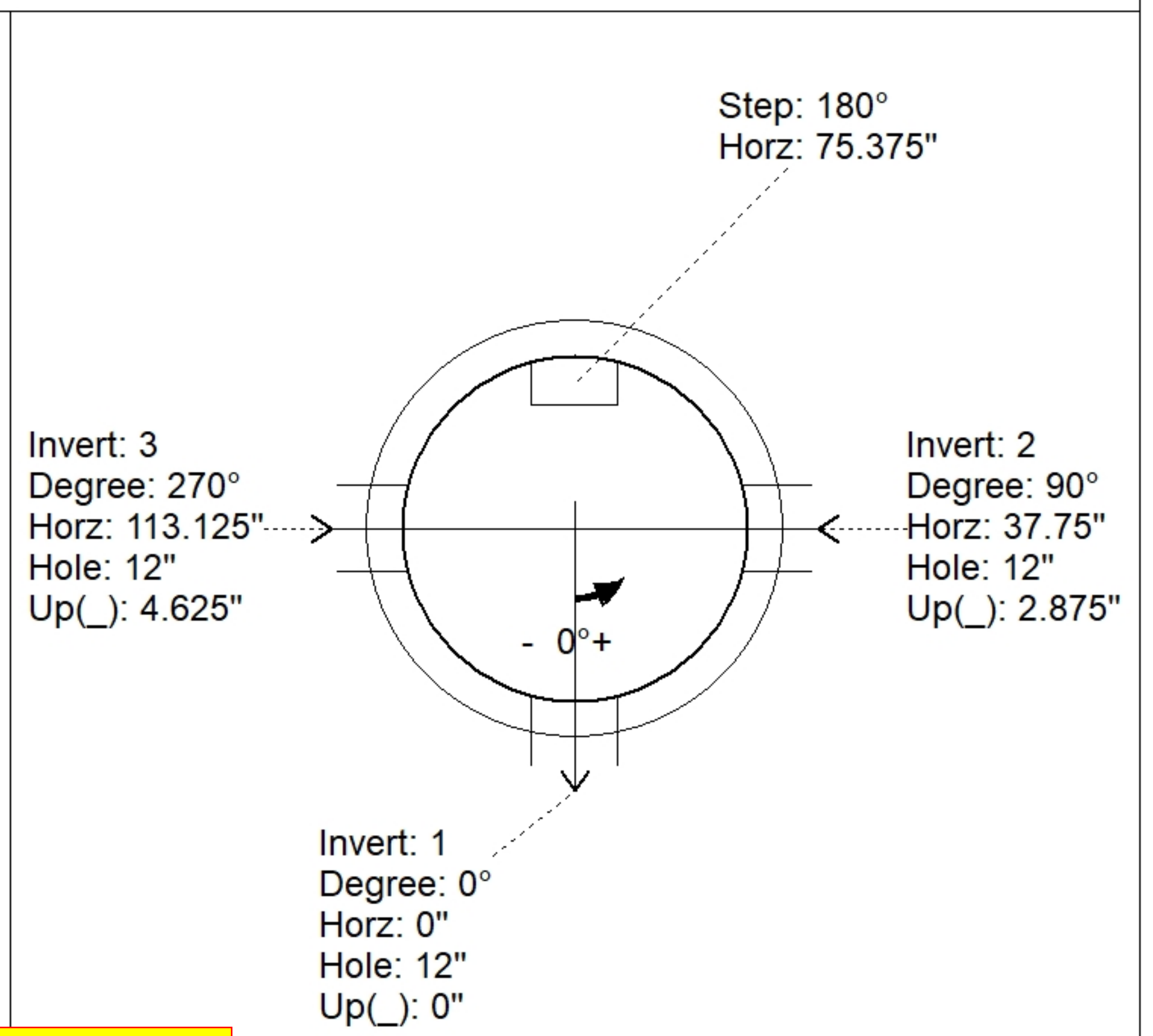
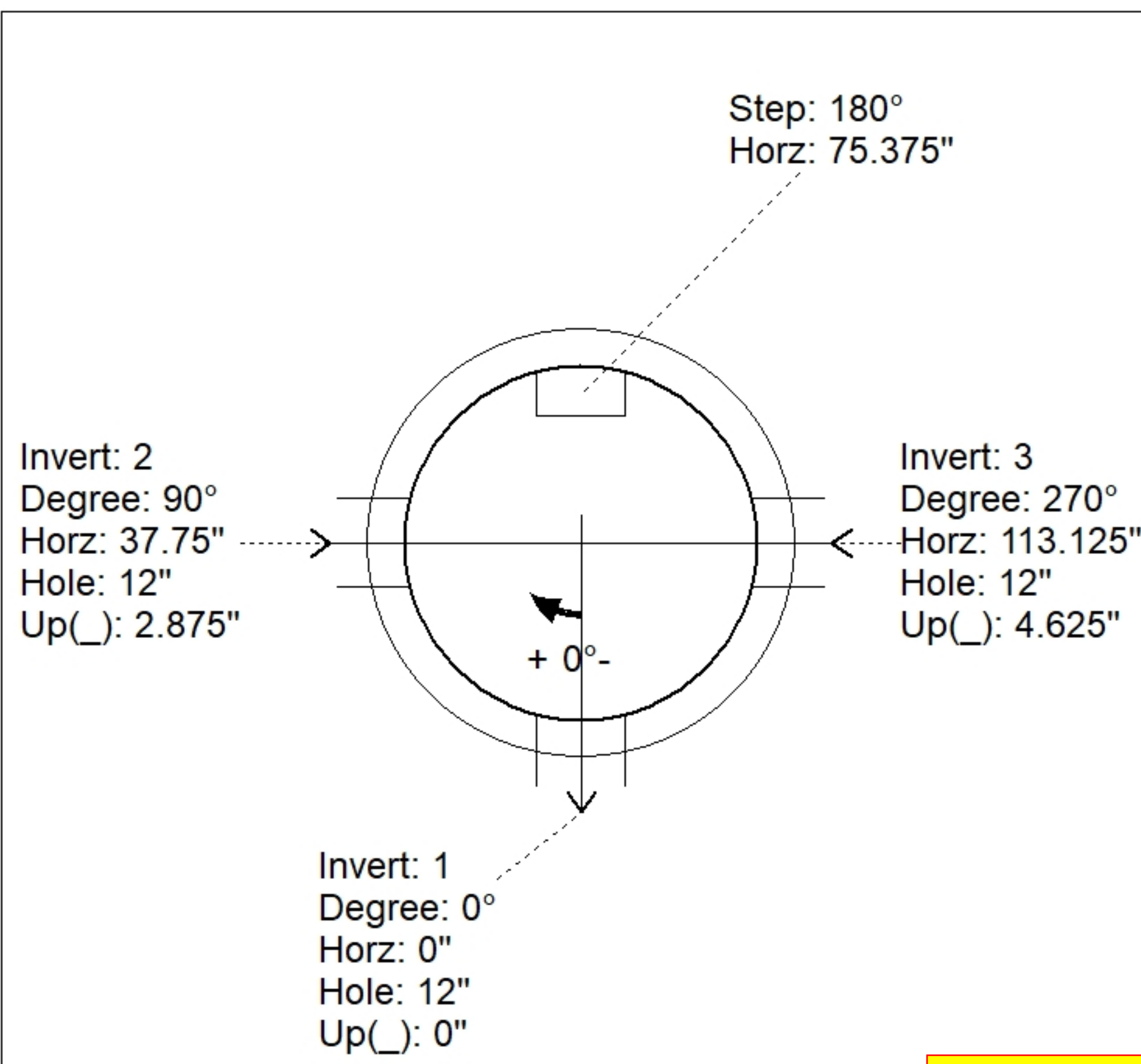
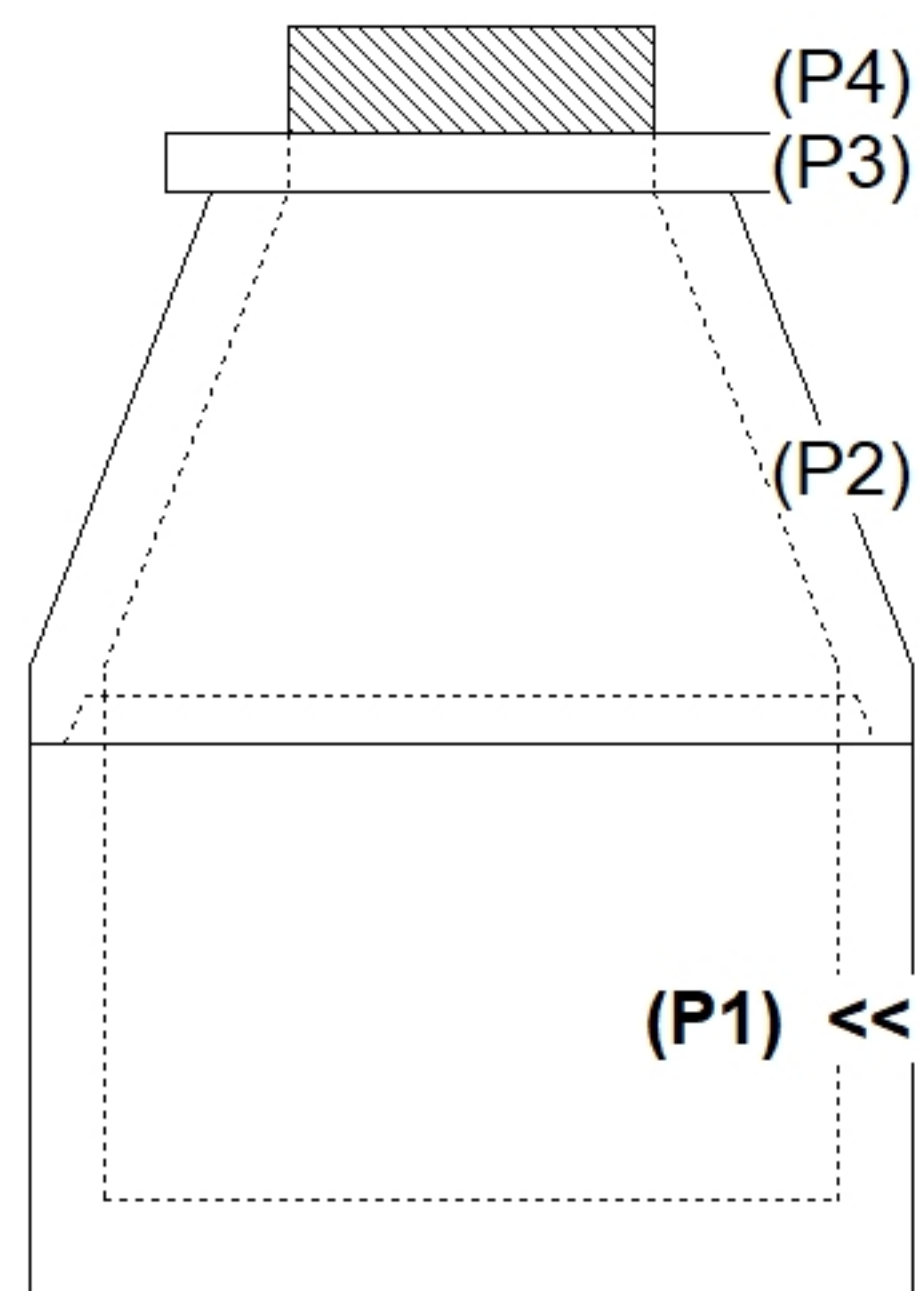

INSIDE WALL DIMENSIONS

FOR INVERT ONLY

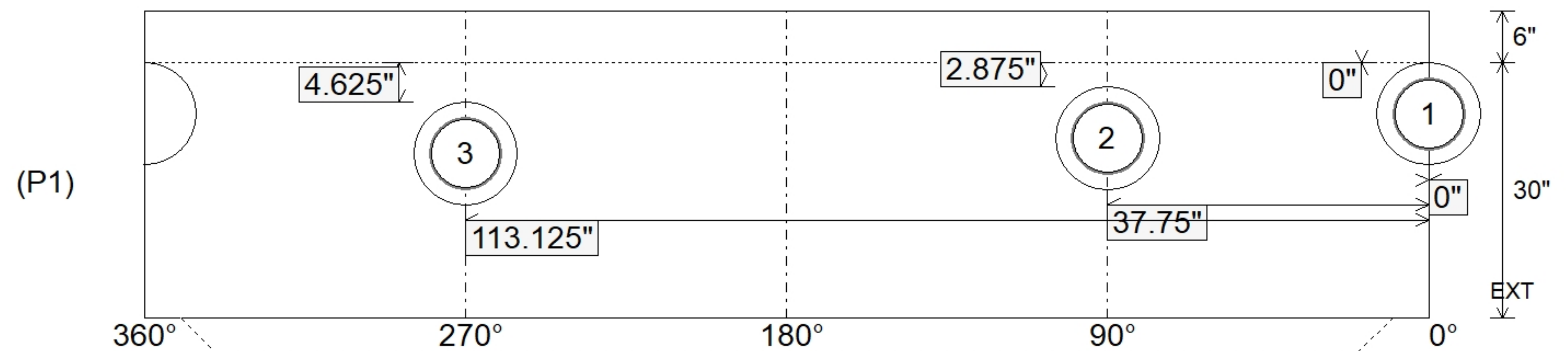

Coating (Int):
 Coating (Ext):

Seam Up: Tongue
 Seam Dn: n/a

Wall Thickness: 5"
 Floor Height: 6"

Height (Int): 30"
 Height (Ext): 36"

Weight (Net): 3282 lb
 Volume (Net): 0.84cu.yd