

Job Name: 25-2860 Grace Park  
 Job Location: Nashville, TN  
 Contractor: Elite Building Group Inc.

Plant: Beaver Dam  
 10/14/2025 3:22:02 PM

Tech: C.Russ  
 PC: A.Chambers



**Structure ID: 2a**

**P2 MH048LD12-28SQ**

**MH FLAT TOP w/28"x28" Hole F/G**

- P3) 28" x 28" - CASTING HEIGHT - 6"
- P2) 48" - MH FLAT TOP w/28"x28" Hole F/G - 12"
- P1) 48" - MH BASE T/n - 60"
- 1) 48" - SGL 1"x14.5' Butyl (2x)
- 3) Hole - 22
- 5) MH Step ML-10-TDS-NCR - 10"

0 lb  
 1368 lb  
 5028 lb  
 0 lb  
 0 lb  
 0 lb  
 -----  
 Structure Total: 6396 lb

- Structure Notes:
1. PER ASTM C478 SPECIFICATIONS.
  2. CONCRETE = 4,000 PSI AT 28 DAYS.
  3. NO INVERT CHANNEL.
  4. REINFORCING PER ASTM A615 (GRADE 60).
  5. CASTING BY OTHERS

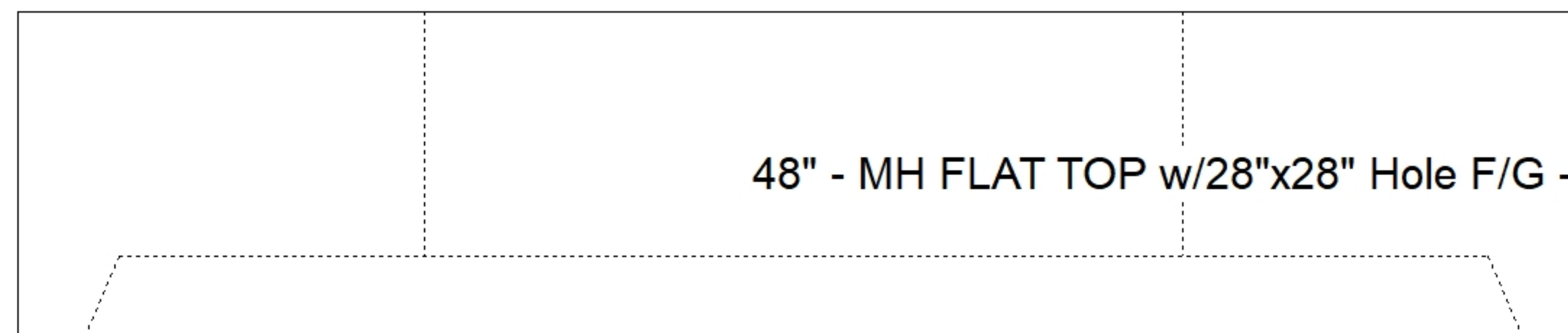
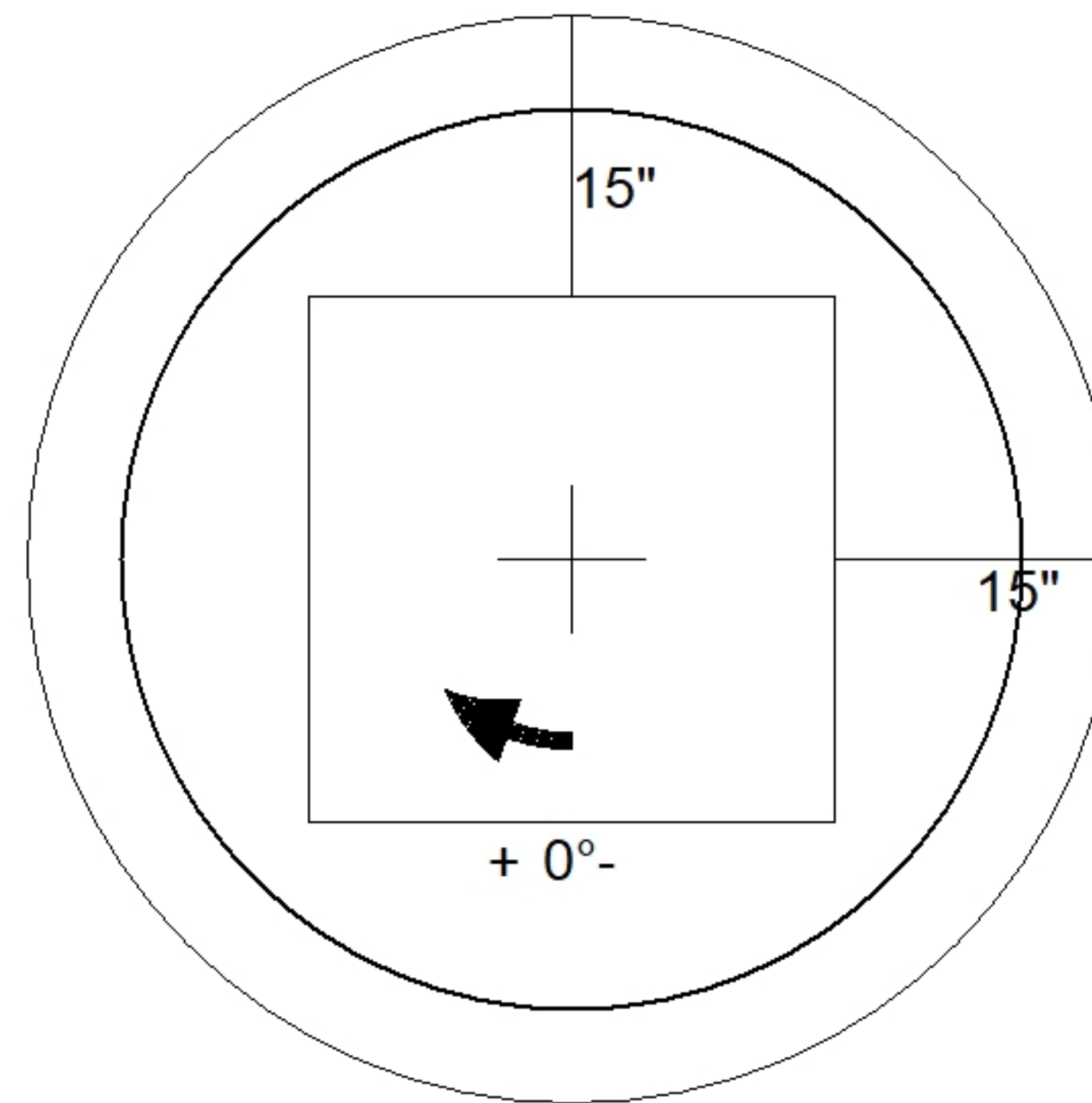

Coating (Int): Coating (Ext):	Seam Up: Flat Seam Dn: Groove	Wall Thickness: 5"	Height (Ext): 12"	Weight (Net): 1368 lb Volume (Net): 0.35cu.yd
----------------------------------	----------------------------------	--------------------	-------------------	--