

**TOP VIEW**

**GENERAL NOTES:**

1. MANUFACTURED TO TDOT D-CB-12 / ASTM C-913 (LATEST REVISION).
2. CONCRETE: 4,500 PSI AT 28 DAYS.
3. REINFORCING: PER TDOT DRAWING D-CB-12S MODIFIED (GRADE 60).
4. WEIGHT: 2,044 LBS
5. JOINT SEALANT TO BE CONSEAL CS-102, 1".

4 EA. CONAC WRA016 (8MM) WIRE ANCHORS REQUIRED MINIMUM.

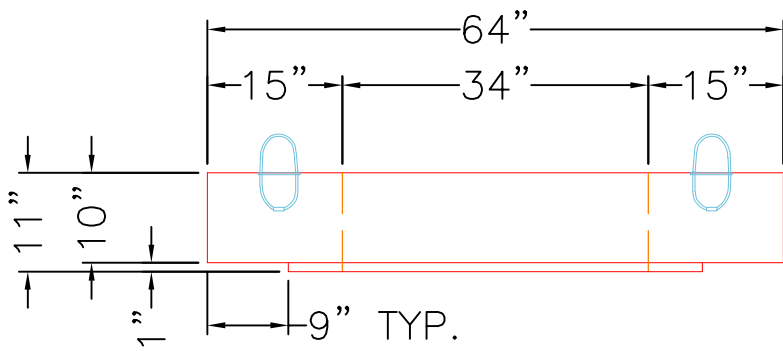

**FRONT VIEW**

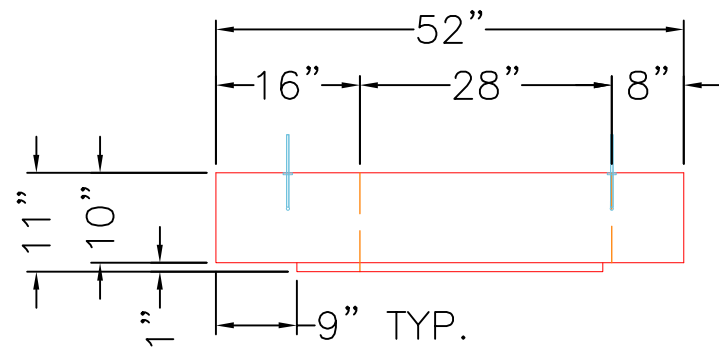

**RIGHT VIEW**

PRODUCTION WORK ORDER		PRODUCT I.D.: BX036048-10LD08W-SP	DESCRIPTION: 52" X 64" X 10" THICK TOP SLAB	
	QUALITY CONTROL CHECKLIST	PRODUCT VIEW: RIGHT SIDE UP	CUSTOMER: CAPITAL CITY CONSTRUCTION SERVICES LLC	
	<input type="checkbox"/> ALL DIMENSIONS CORRECT.	PLANT: BEAVER DAM, KY.	PROJECT: TDOT RUTHERFORD CO CNZ193	
	<input type="checkbox"/> LIFTERS INSTALLED.	WEIGHT: 2,044 LBS.	STRUCTURE: CB-2	
	<input type="checkbox"/> OPENING CORRECT.	TOP SECTION JOINT: N/A	ORDER NO: 25-2772	
	<input type="checkbox"/> REINFORCING CORRECT.	BASE SECTION JOINT: N/A	PC: A. CHAMBERS	DRAWING: J. COPPAGE
<input type="checkbox"/> SURFACE QUALITY ACCEPTABLE.	QC CHECK INITIALS:	DATE: 10/1/25	SCALE: NTS	PG. 1 of 1
<input type="checkbox"/> EDGES CHAMFERED.				
<input type="checkbox"/> ALL PATCHWORK ACCEPTABLE.				