

Job Name: 25-2727 - S English Station Storage  
 Job Location: Louisville, KY  
 Contractor: H&W Landwork

Plant: Beaver Dam, KY  
 2/3/2026 6:40:49 PM

Tech: J. Coppage - F  
 PC: T. Lewis



**Structure ID: 10**

**P1 MH048BA30**

**MH BASE Custom Ht T/n**

- P3) 24" - CASTING HEIGHT - 7"
- P2) 48" - MH FLAT TOP w/ 24" ECC Hole F/G - 12"
- P1) 48" - MH BASE Custom Ht T/n - 30"
- 1) CASTING - HOE MC-420 F/C Storm LOU-MSD
- 1) 48" - Conseal CS-102 1.00"
- 2) Hole - 16
- 3) MH Step ML-10-TDS-NCR - 10"

0 lb  
 1561 lb  
 3255 lb  
 340 lb  
 0 lb  
 0 lb  
 0 lb  
 -----  
 5156 lb

Structure Total: 5156 lb

- Structure Notes:**
1. PER ASTM C-478 SPECIFICATIONS
  2. CONCRETE: 4,500 PSI AT 28 DAYS
  3. REINFORCEMENT: PER ASTM A615
  4. NO STORM INVERT
  5. STEPS AT 247 DEGREES
  6. HOE MC-420 FRAME & COVER "STORM LOU-MSD" SUPPLIED BY ICAST

Rim: 707.1' Rim to Invert: 4.1' Slack: 0.2" Sump: 0" Step Position: 247°

Position	Elev	Angle	Ext. (cw)	Pipe	Pipe OD	Connector	Hole	Horz Size	Up ( )	Offset
Invert 1	703'	0°	0"	12" HDPE	14.5"	Hole 16	16"	16.312"	-1.25"	0"
Invert 2	703'	134°	67.823"	12" HDPE	14.5"	Hole 16	16"	16.312"	-1.25"	0"
Invert 3										
Invert 4										
Invert 5										
Invert 6										
Invert 7										
Invert 8										

RIGHT-SIDE UP VIEW (int. dimensions)

UPSIDE-DOWN VIEW (int. dimenions)

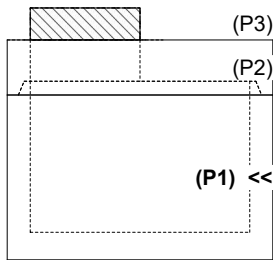
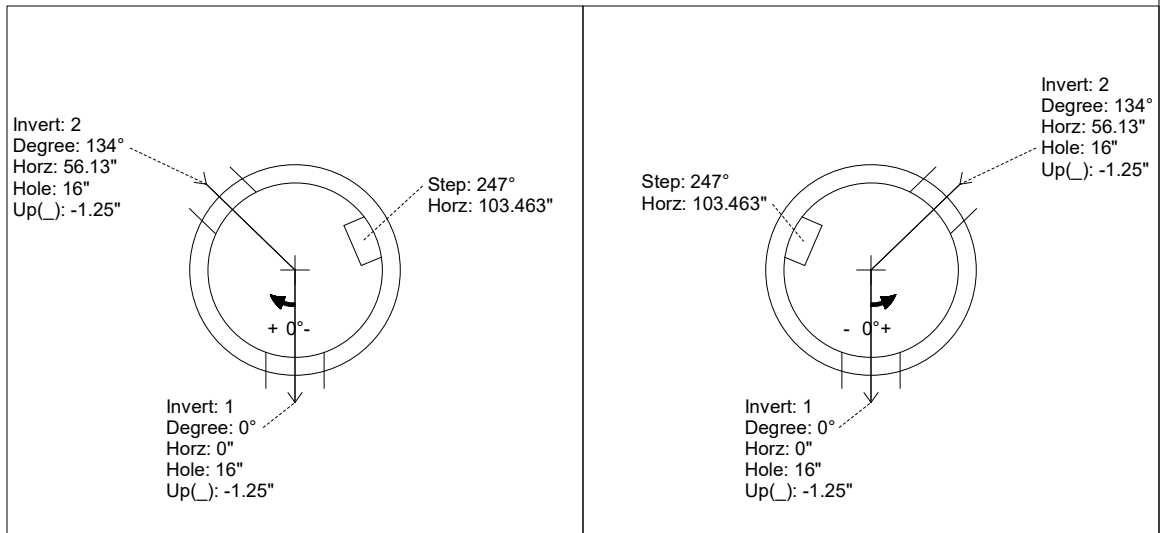

INSIDE WALL DIMENSIONS

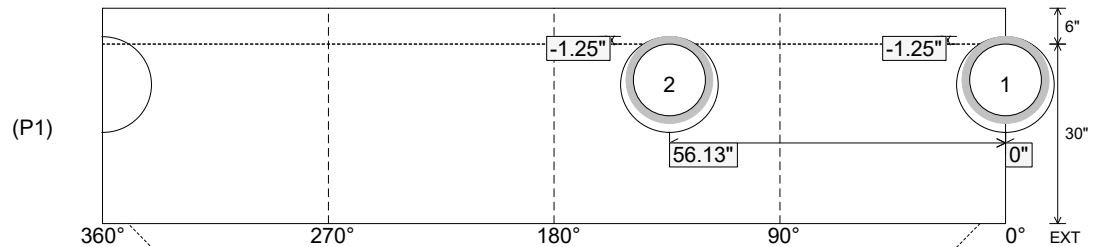

Coating (Int):  
 Coating (Ext):

Seam Up: Tongue  
 Seam Dn: n/a

Wall Thickness: 5"  
 Floor Height: 6"

Height (Int): 30"  
 Height (Ext): 36"

Weight (Net): 3255 lb  
 Volume (Net): 0.83cu.yd