

PLAN VIEW

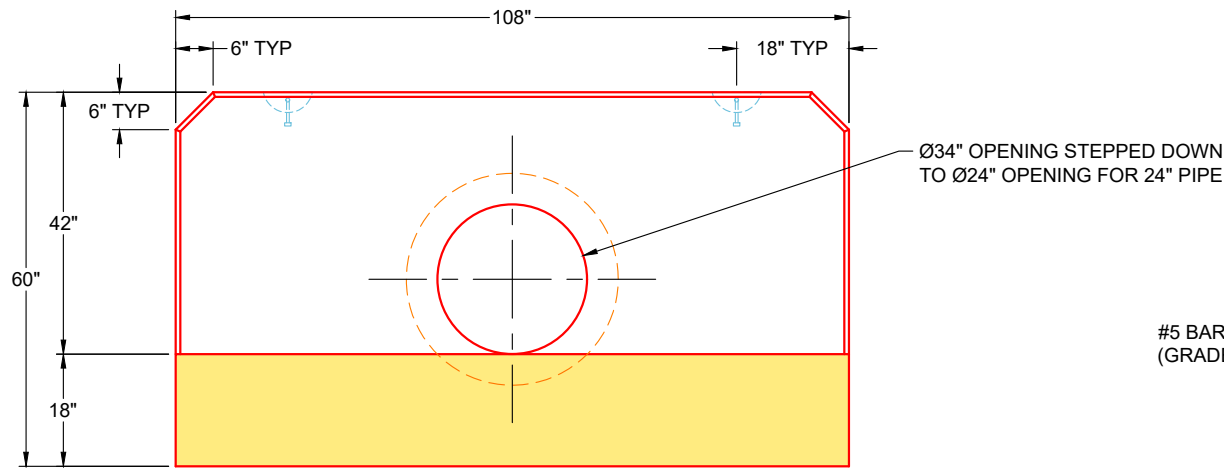

FRONT VIEW

GENERAL NOTES:

1. CONCRETE: KYTC APPROVED
2. REINFORCEMENT: #5 BAR @ 12" C.C. E.W. (GRADE 60) - 2" MIN. REBAR CLEARANCE (TYP)
3. REINFORCING BARS TO BE TACK WELDED OR TIED
4. DRAWING TO BE USED IN CONJUNCTION WITH KYTC STD. DRAWINGS RDH-005-02 & THE STANDARD SPECIFICATIONS FOR ROAD & BRIDGE CONSTRUCTION
5. 3/4" CHAMFER ON ALL EXPOSED EDGES
6. WEIGHT: 9,605 LBS
 - FIRST POUR: 4,475 LBS
 - SECOND POUR: 5,130 LBS

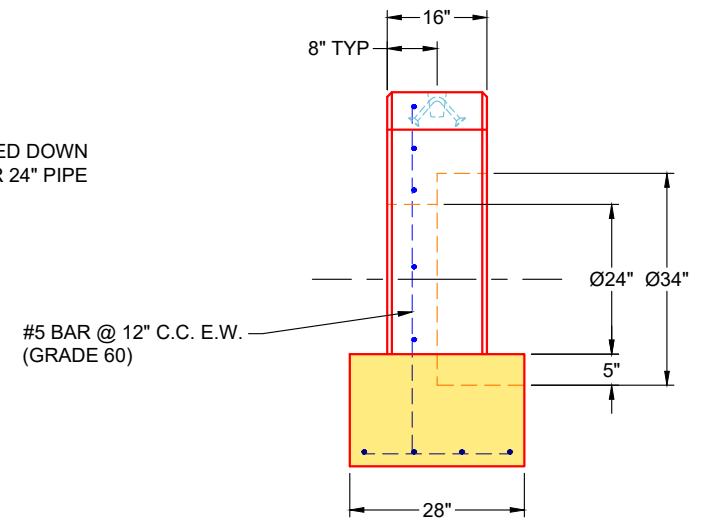

SIDE VIEW

PRODUCTION WORK ORDER

PRODUCT I.D.: HWKYTC-STD24

DESCRIPTION: 24" KYTC STANDARD STRAIGHT HW



QUALITY CONTROL CHECKLIST

- ALL DIMENSIONS CORRECT.
- LIFTERS INSTALLED.
- OPENING CENTERED.
- REINFORCING CORRECT.
- SURFACE QUALITY ACCEPTABLE.
- EDGES CHAMFERED.
- ALL PATCHWORK ACCEPTABLE.

PRODUCT VIEW: RIGHT SIDE UP

CUSTOMER: CORNELL HARBISON EXCAVATING

PLANT: BEAVER DAM, KY

PROJECT: WHISPERING OAKS SUBDIVISION

WEIGHT: 9,605 LBS

STRUCTURE: 4

TOP SECTION JOINT: N / A

ORDER NO: 25-2686

BASE SECTION JOINT: N / A

PE: J.H. ROSS

DRAWING: K. CARDWELL

QC CHECK INITIALS:

DATE: 02/06/26

SCALE: NTS

PG. 1 OF 1

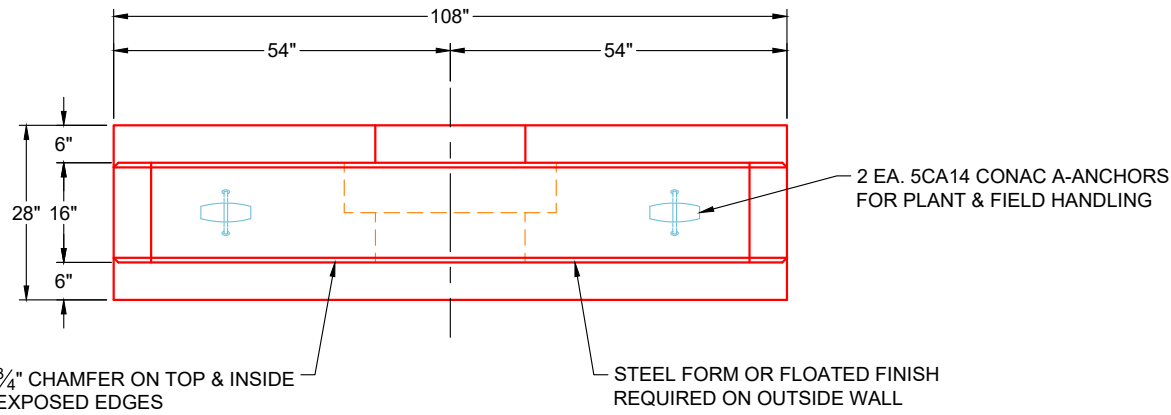

PLAN VIEW

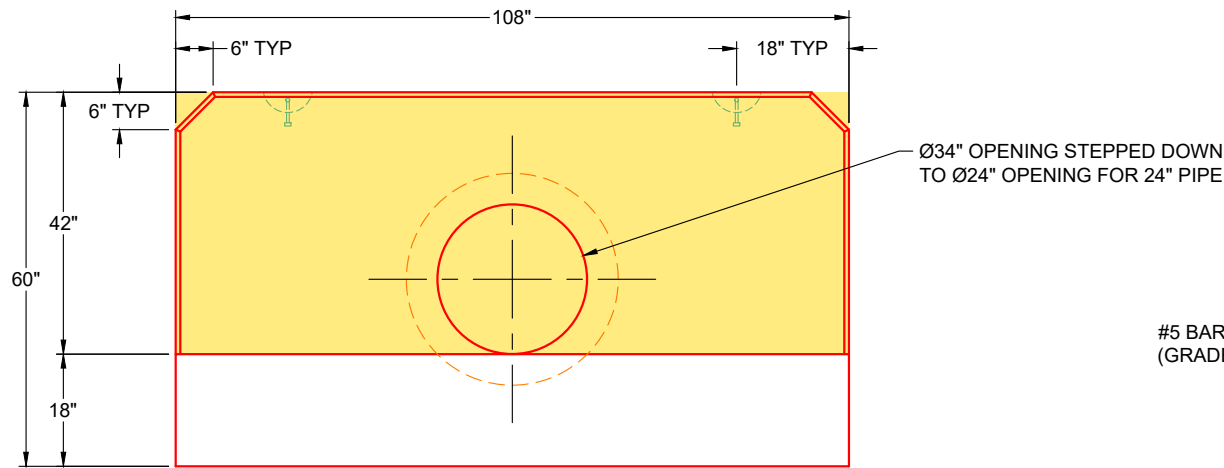

FRONT VIEW

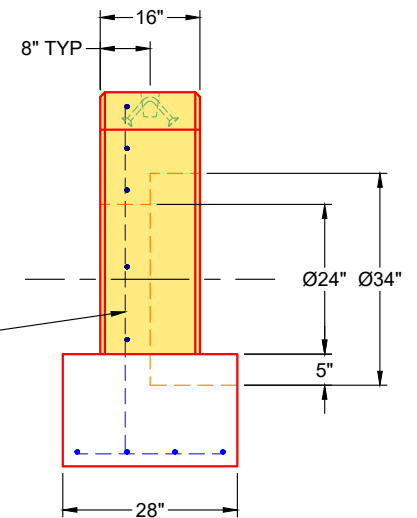

SIDE VIEW

GENERAL NOTES:

1. CONCRETE: KYTC APPROVED
2. REINFORCEMENT: #5 BAR @ 12" C.C. E.W. (GRADE 60) - 2" MIN. REBAR CLEARANCE (TYP)
3. REINFORCING BARS TO BE TACK WELDED OR TIED
4. DRAWING TO BE USED IN CONJUNCTION WITH KYTC STD. DRAWINGS RDH-005-02 & THE STANDARD SPECIFICATIONS FOR ROAD & BRIDGE CONSTRUCTION
5. 3/4" CHAMFER ON ALL EXPOSED EDGES
6. WEIGHT: 9,605 LBS
 - FIRST POUR: 4,475 LBS
 - SECOND POUR: 5,130 LBS

PRODUCTION WORK ORDER

PRODUCT I.D.: HWKYTC-STD24

DESCRIPTION: 24" KYTC STANDARD STRAIGHT HW



QUALITY CONTROL CHECKLIST

- ALL DIMENSIONS CORRECT.
- LIFTERS INSTALLED.
- OPENING CENTERED.
- REINFORCING CORRECT.
- SURFACE QUALITY ACCEPTABLE.
- EDGES CHAMFERED.
- ALL PATCHWORK ACCEPTABLE.

PRODUCT VIEW: RIGHT SIDE UP

CUSTOMER: CORNELL HARBISON EXCAVATING

PLANT: BEAVER DAM, KY

PROJECT: WHISPERING OAKS SUBDIVISION

WEIGHT: 9,605 LBS

STRUCTURE: 4

TOP SECTION JOINT: N / A

ORDER NO: 25-2686

BASE SECTION JOINT: N / A

PE: J.H. ROSS

DRAWING: K. CARDWELL

QC CHECK INITIALS:

DATE: 02/06/26

SCALE: NTS

PG. 1 OF 1