

Job Name: 25-2649B - The Laurel Assisted Living Facility (Sanitary)
 Job Location: Bowling Green, KY
 Contractor: Infinity Pipeline, Inc.

Plant: Beaver Dam, KY
 1/21/2026 11:01:29 AM

Tech: K. Cardwell
 PC: E. Bradley



Structure ID: MH-9

P2 MH048CN42

ECC CONE w/ 24" HOLE F/G

- P3) 24" - CASTING HEIGHT - 7"
- P2) 48" - ECC CONE w/ 24" HOLE F/G - 42"
- P1) 48" - MH BASE T/n - 36"
- 1) JOINT WRAP - 12" WD x 048" MAC WRAP
- 1) 48" - MH INVERT CHANNEL - FULL HEIGHT
- 1) CASTING - HOE MC-375 F/C Sanitary
- 1) 48" - Conseal CS-102 1.00" (Double)
- 3) A-Lok - 0285
- 6) MH Step ML-10-TDS-NCR - 10"

0 lb
 3200 lb
 3751 lb
 0 lb
 1440 lb
 271 lb
 0 lb
 3 lb
 0 lb

 Structure Total: 8665 lb

- Structure Notes:
 STATION: 3+73.94
1. PER WCWD & ASTM C-478 SPECS
 2. CONCRETE: 4,500 PSI AT 28 DAYS
 3. REINFORCEMENT: PER ASTM A615
 4. INVERT CHANNEL REQUIRED
 5. STEPS AT 0 DEGREES
 6. HOE MC-375 FRAME & COVER "SANITARY" SUPPLIED BY ICAST

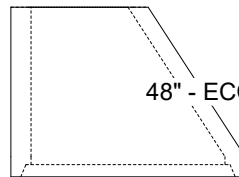
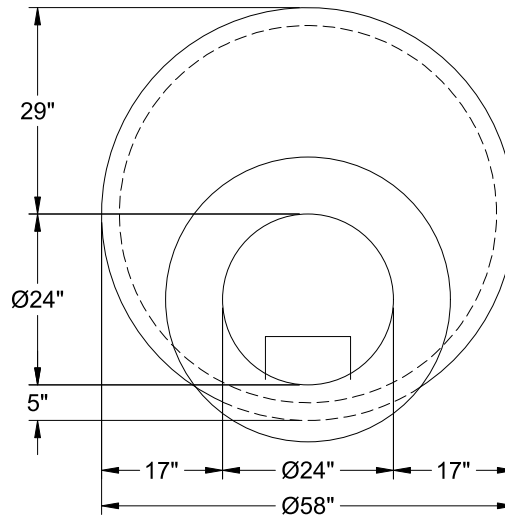

48" - ECC CONE w/ 24" HOLE F/G - 42" - (P2)

Coating (Int):
 Coating (Ext):

Seam Up: Flat
 Seam Dn: Groove

Wall Thickness: 5"

Height (Ext): 42"

Weight (Net): 3200 lb
 Volume (Net): 0.5cu.yd