

Job Name: 25-2649B - The Laurel Assisted Living Facility (Sanitary)
 Job Location: Bowling Green, KY
 Contractor: Infinity Pipeline, Inc.

Plant: Beaver Dam, KY

Tech: K. Cardwell

1/21/2026 11:01:14 AM

PC: E. Bradley



Structure ID: MH-9

P1 MH048BA36

MH BASE T/n

- P3) 24" - CASTING HEIGHT - 7"
- P2) 48" - ECC CONE w/ 24" HOLE F/G - 42"
- P1) 48" - MH BASE T/n - 36"
- 1) JOINT WRAP - 12" WD x 048" MAC WRAP
- 1) 48" - MH INVERT CHANNEL - FULL HEIGHT
- 1) CASTING - HOE MC-375 F/C Sanitary
- 1) 48" - Conseal CS-102 1.00" (Double)
- 3) A-Lok - 0285
- 6) MH Step ML-10-TDS-NCR - 10"

0 lb
 3200 lb
 3751 lb
 0 lb
 1440 lb
 271 lb
 0 lb
 3 lb
 0 lb

 Structure Total: 8665 lb

Structure Notes:
 STATION: 3+73.94
 1. PER WCWD & ASTM C-478 SPECS
 2. CONCRETE: 4,500 PSI AT 28 DAYS
 3. REINFORCEMENT: PER ASTM A615
 4. INVERT CHANNEL REQUIRED
 5. STEPS AT 0 DEGREES
 6. HOE MC-375 FRAME & COVER "SANITARY" SUPPLIED BY ICAST

Rim: 551.44' Rim to Invert: 7.11' Slack: 1.195" Sump: 0.875" Step Position: 0°

Position	Elev	Angle	Ext. (cw)	Pipe	Pipe OD	Connector	Hole	Horz Size	Up ()	Offset
Invert 1	544.33'	0°	0"	8" PVC SDR35	8.5"	A-Lok 0285	9.75"	9.818"	0"	0"
Invert 2	544.43'	135°	68.33"	8" PVC SDR35	8.5"	A-Lok 0285	9.75"	9.818"	1.2"	0"
Invert 3	545.84'	225°	113.883"	8" PVC SDR35	8.5"	A-Lok 0285	9.75"	9.818"	18.12"	0"
Invert 4										
Invert 5										
Invert 6										
Invert 7										
Invert 8										

RIGHT-SIDE UP VIEW (int. dimensions)

UPSIDE-DOWN VIEW (int. dimensions)

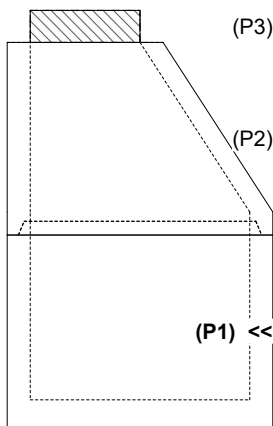
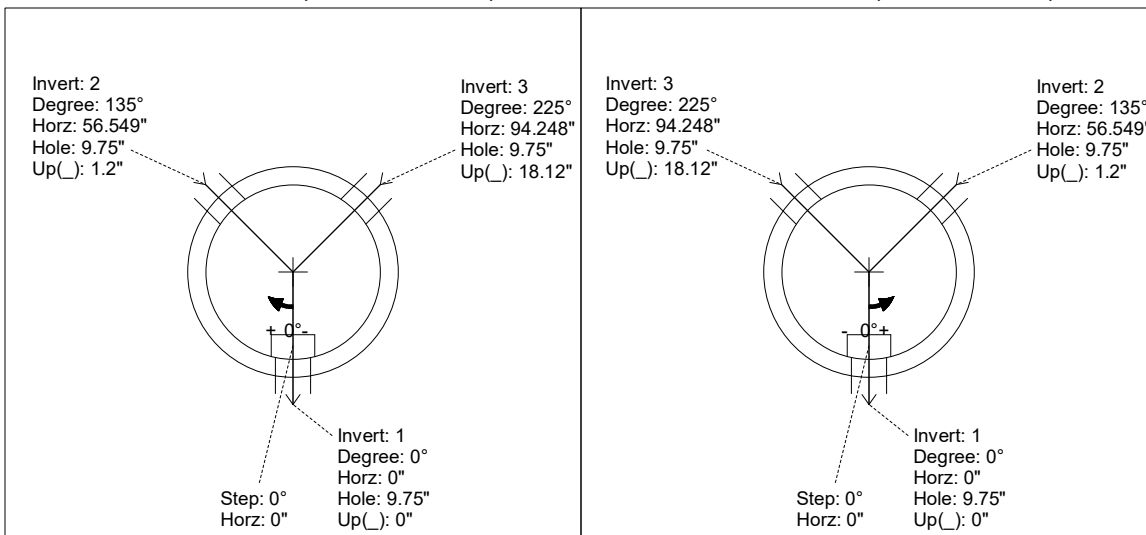

INSIDE WALL DIMENSIONS

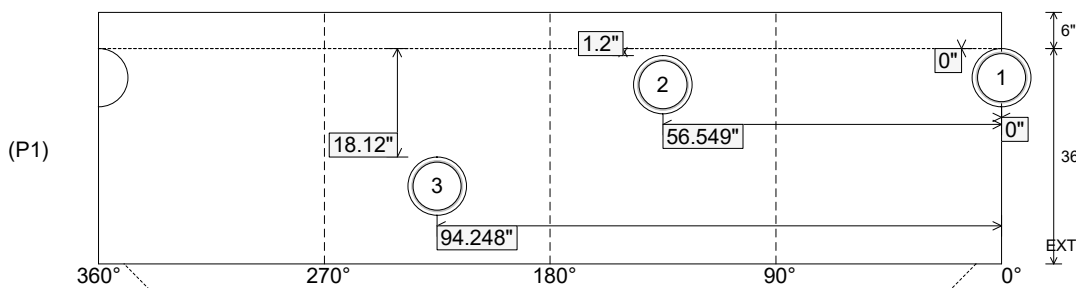

Coating (Int):
 Coating (Ext):

Seam Up: Tongue
 Seam Dn: n/a

Wall Thickness: 5"
 Floor Height: 6"

Height (Int): 36"
 Height (Ext): 42"

Weight (Net): 3751 lb
 Volume (Net): 0.96cu.yd

Job Name: 25-2649B - The Laurel Assisted Living Facility (Sanitary)
 Job Location: Bowling Green, KY
 Contractor: Infinity Pipeline, Inc.

Plant: Beaver Dam, KY

Tech: K. Cardwell

1/21/2026 11:01:14 AM

PC: E. Bradley



Structure ID: MH-9

P1 MH048BA36

MH BASE T/n

- P3) 24" - CASTING HEIGHT - 7"
- P2) 48" - ECC CONE w/ 24" HOLE F/G - 42"
- P1) 48" - MH BASE T/n - 36"
- 1) JOINT WRAP - 12" WD x 048" MAC WRAP
- 1) 48" - MH INVERT CHANNEL - FULL HEIGHT
- 1) CASTING - HOE MC-375 F/C Sanitary
- 1) 48" - Conseal CS-102 1.00" (Double)
- 3) A-Lok - 0285
- 6) MH Step ML-10-TDS-NCR - 10"

0 lb
 3200 lb
 3751 lb
 0 lb
 1440 lb
 271 lb
 0 lb
 3 lb
 0 lb

 Structure Total: 8665 lb

Structure Notes:
 STATION: 3+73.94
 1. PER WCWD & ASTM C-478 SPECS
 2. CONCRETE: 4,500 PSI AT 28 DAYS
 3. REINFORCEMENT: PER ASTM A615
 4. INVERT CHANNEL REQUIRED
 5. STEPS AT 0 DEGREES
 6. HOE MC-375 FRAME & COVER "SANITARY" SUPPLIED BY ICAST

Rim: 551.44' Rim to Invert: 7.11' Slack: 1.195" Sump: 0.875" Step Position: 0°

Position	Elev	Angle	Ext. (cw)	Pipe	Pipe OD	Connector	Hole	Horz Size	Up ()	Offset
Invert 1	544.33'	0°	0"	8" PVC SDR35	8.5"	A-Lok 0285	9.75"	9.818"	0"	0"
Invert 2	544.43'	135°	68.33"	8" PVC SDR35	8.5"	A-Lok 0285	9.75"	9.818"	1.2"	0"
Invert 3	545.84'	225°	113.883"	8" PVC SDR35	8.5"	A-Lok 0285	9.75"	9.818"	18.12"	0"
Invert 4										
Invert 5										
Invert 6										
Invert 7										
Invert 8										

RIGHT-SIDE UP VIEW (int. dimensions)

UPSIDE-DOWN VIEW (int. dimenions)

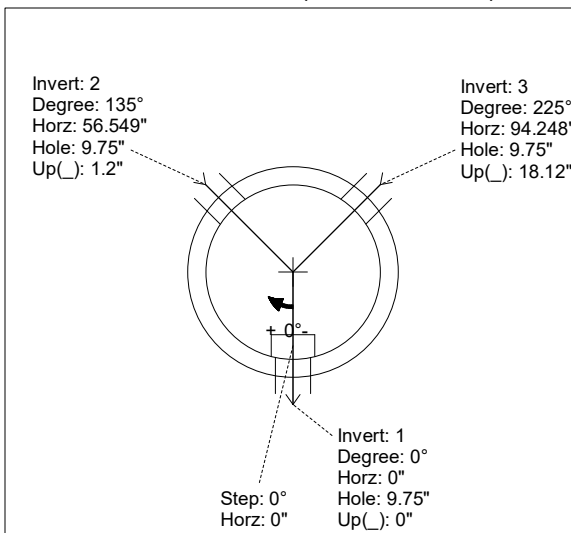

INVERT CHANNEL DRAWING

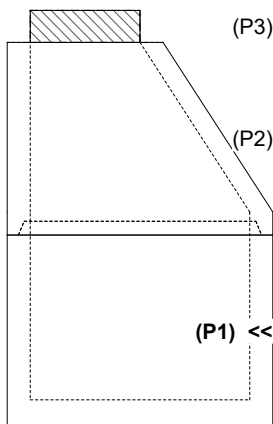

INSIDE WALL DIMENSIONS

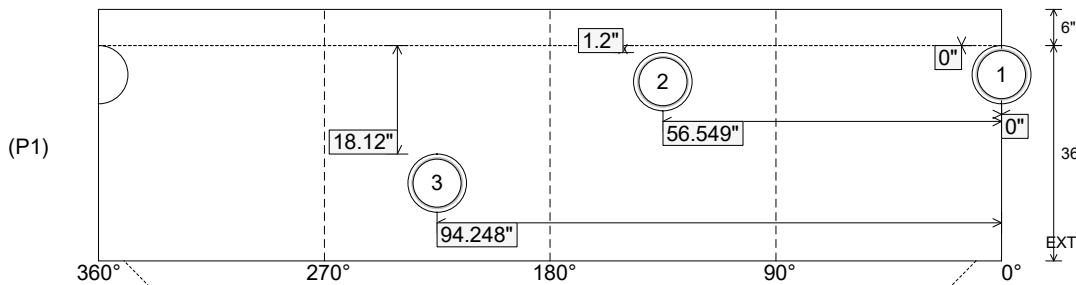

Coating (Int):
 Coating (Ext):

Seam Up: Tongue
 Seam Dn: n/a

Wall Thickness: 5"
 Floor Height: 6"

Height (Int): 36"
 Height (Ext): 42"

Weight (Net): 3751 lb
 Volume (Net): 0.96cu.yd